

STANDARD CONSTRUCTION
MATERIAL:

16GA GALVANIZED STEEL ASTM A-653 HOT-DIPPED
12GA GALVANIZED STEEL ASTM A-653 HOT-DIPPED

LEGS:

1.5" x 1.5" x 16GA GALVANIZED STEEL SQUARE LEG
18", 24" AND 36" LEG LENGTHS STANDARD

CROSSBAR:

1" x 1" x 16GA GALVANIZED STEEL SQUARE TUBE
0.8125" x 0.8125" x 16GA GALVANIZED STEEL
SQUARE TUBE

ANGLE:

1.875" x 1.75" x 12GA GALVANIZED STEEL ANGLE
1.125" x 0.875" x 16GA GALVANIZED STEEL ANGLE
22" DEPTH STANDARD
CUSTOM FRAME DEPTH AVAILABLE

ADJUSTABLE WIDTHS:

N: 14" - 24"

W: 17" - 30"

CUSTOM ADJUSTABLE WIDTH OR FIXED WIDTHS
AVAILABLE

OPTIONS:

FILTER RACK CAN BE EXCLUDED AT CUSTOMER'S
REQUEST.
HEAT PUMP CONFIGURATION AVAILABLE.

STANDARD SIZES:

PART NO.	HEIGHT	WIDTH TYPE	QTY.
UHB18N	18"	NARROW	1
UHB24N	24"	NARROW	1
UHB36N	36"	NARROW	1
UHB18W	18"	WIDE	1
UHB24W	24"	WIDE	1
UHB36W	36"	WIDE	1

JOB NAME:
LOCATION:
ARCHITECT:
ENGINEER:
CONTRACTOR:
CONTACT MIAMI TECH INC. FOR ADDITIONAL INFORMATION OR WITH SPECIAL REQUIREMENTS.
3611 NW 74TH ST MIAMI, FL 33147 PHONE: 305-693-7054 FAX: 305-693-6152
WEB: WWW.MIAMITECH.COM EMAIL: SALES@MIAMITECH.COM

FEATURES:

NO ASSEMBLY REQUIRED.

1.5" X 1.5" BOX STEEL LEGS PROVIDE EXCELLENT STABILITY
AND CORROSION RESISTANCE.

ADJUSTABLE WIDTH ALLOWS THIS STAND TO BE USED WITH
VARIOUS SIZED UNITS.

FULL WELDED SEAMS CREATE A PERMANENT CONNECTION
FOR ADDED STRENGTH.

PLASTIC CAPPED LEG BOTTOMS PROTECT SUBSTRATES FROM
SCRATCHING AND GOUGING.

CUSTOM SIZES UPON REQUEST TO MEET CLEAR HEIGHT
REQUIREMENTS.

SEE OUR ORDER FORM FOR CUSTOM SIZES.

MAXIMUM UNIT WEIGHT: 600LBS

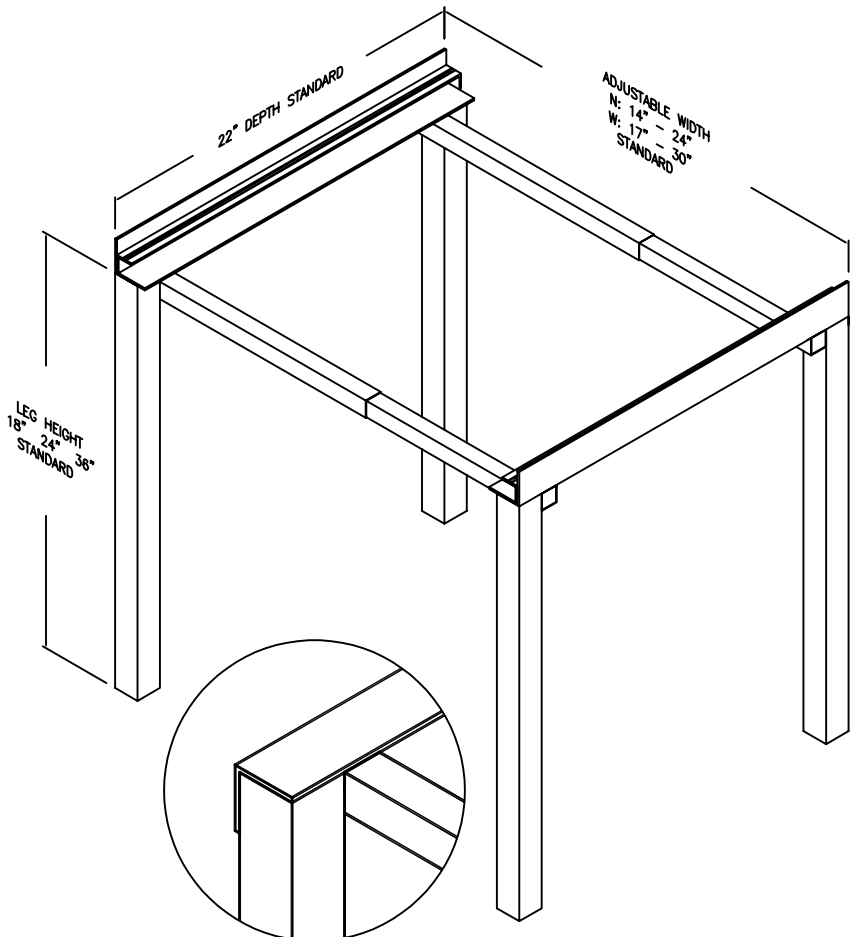

UHB-HP:
HEAT PUMP CONFIGURATION

UHB

ULTRA HEAVY DUTY ADJUSTABLE AIR HANDLER BASE
PRODUCT SPECIFICATIONS

NOTE: ALL DRAWINGS SUBJECT TO CHANGE WITHOUT PRIOR NOTICE.

miami tech inc.

DRAWN BY:	AF	DATE:	08/24/07	SCALE:	NOT TO SCALE	DRAWING NO.:	UHB
CHECKED BY:	IG	DATE:	7/8/19	REVISION:	F		