



STANDARD CONSTRUCTION

BODY:
28 GAUGE HOT-DIPPED GALVANIZED STEEL SHEET

OPTIONS:
W/FLANGE (TWBMF)
W/FLANGE AND INSULATION (TWB)
CUSTOM SIZES AVAILABLE

STANDARD SIZES:

W X H
8 X 4
8 X 6
8 X 8
10 X 6
10 X 8
10 X 10
12 X 6
12 X 8
12 X 10
12 X 12
14 X 6
14 X 8
14 X 10
14 X 12
14 X 14
16 X 6
16 X 8
18 X 10

FEATURES

DESIGN INCLUDES 1/2" DRYWALL LIP ON BOTH SIDES OF BOOT.

OPENING 1/4" OVERSIZED TO ACCOMMODATE REGISTER/GRILLE.

DUAL BEAD BOX DESIGN FOR ADDED STRENGTH.

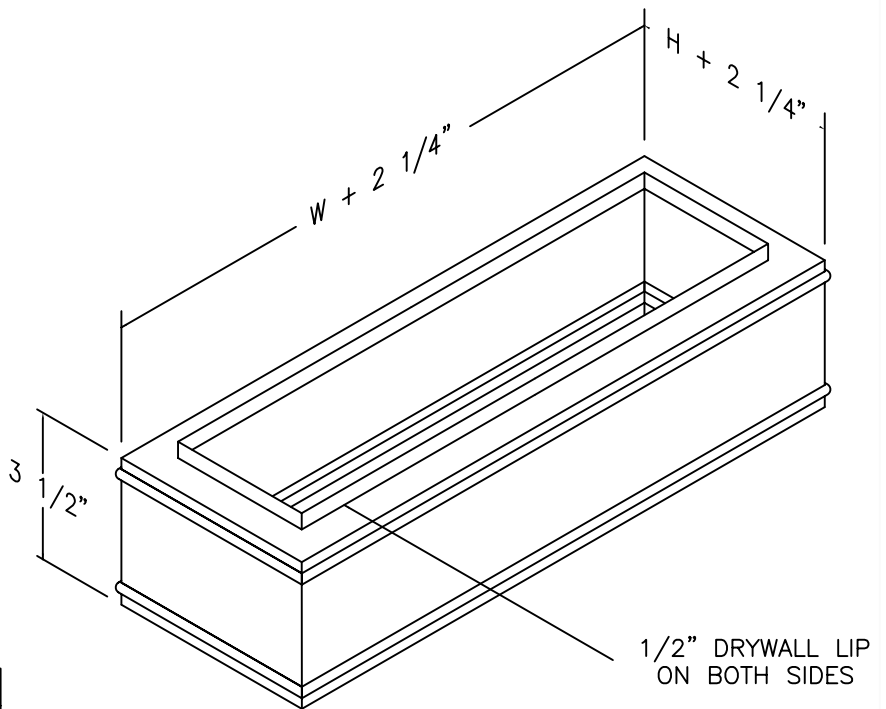

JOB NAME:
LOCATION:
ARCHITECT:
ENGINEER:
CONTRACTOR:
CONTACT MIAMI TECH INC. FOR ADDITIONAL INFORMATION OR WITH SPECIAL REQUIREMENTS. 3611 NW 74TH ST MIAMI, FL 33147 PHONE: 305-693-7054 FAX: 305-693-6152 WEB: WWW.MIAMITECH.COM EMAIL: SALES@MIAMITECH.COM

TWBM

METAL THROUGH WALL BOOT
PRODUCT SPECIFICATIONS

NOTE: ALL DRAWINGS SUBJECT TO CHANGE WITHOUT PRIOR NOTICE.



DRAWN BY: AF	DATE: 09/18/07	SCALE: NOT TO SCALE	DRAWING NO.
CHECKED BY: IG	DATE: 09/18/07	REVISION: 2	

TWBM