



STANDARD CONSTRUCTION

BODY:
12"-14" 26 GAUGE
ASTM A-653 HOT-DIPPED
GALVANIZED STEEL

STANDARD SIZES:

MODEL	DIAMETER	LENGTH
TCPU12	12"	4"
TCPU14	14"	4"
TCPUL12NF	12"	11 7/8"
TCPUL14NF	14"	11 7/8"

FEATURES

BODY MECHANICALLY FASTENED
TOGETHER TO INSURE A RIGID
ASSEMBLY.

"NF" = NO FLANGE.

SOLD INDIVIDUALLY.

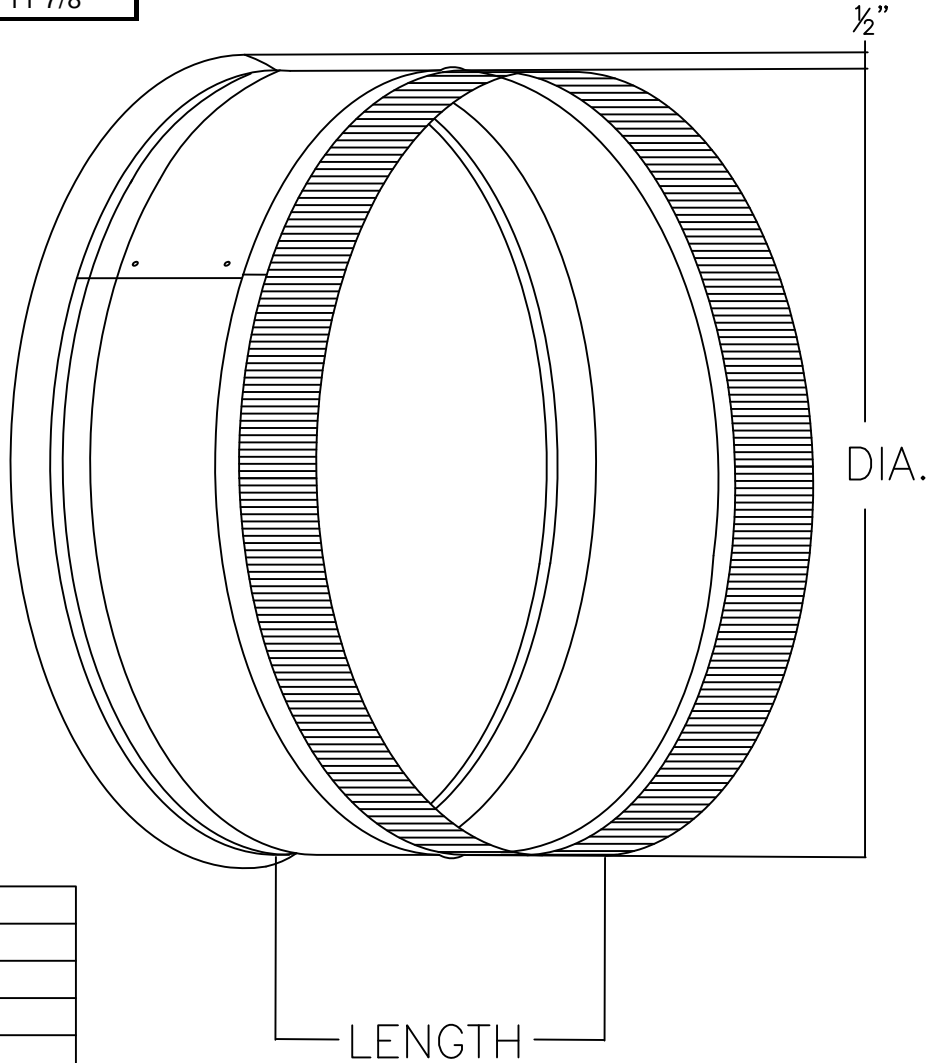

JOB NAME:
LOCATION:
ARCHITECT:
ENGINEER:
CONTRACTOR:
CONTACT MIAMI TECH INC. FOR ADDITIONAL INFORMATION OR WITH SPECIAL REQUIREMENTS.
3611 NW 74TH ST MIAMI, FL 33147 PHONE: 305-693-7054 FAX: 305-693-6152
WEB: WWW.MIAMITECH.COM EMAIL: SALES@MIAMITECH.COM

TCPU
NORDYNE TAKE-OFF COLLAR FOR
PACKAGE-UNIT
PRODUCT SPECIFICATIONS



DRAWN BY: AF	DATE: 12/18/2008	SCALE: NOT TO SCALE
CHECKED BY: IV	DATE: 5/13/2013	REVISION: C

DRAWING NO.
TCPU