

STANDARD CONSTRUCTION
BODY:

20GA POWDERCOATED GALVANIZED STEEL
 14GA POWDERCOATED GALVANIZED STEEL
 (SWING ARMS)

FEATURES

GALVANIZED STEEL PROVIDES EXCELLENT CORROSION RESISTANCE AND LONGEVITY.

FULLY POWDER COATED TO GIVE A LONG LASTING, CORROSION RESISTANT FINISH ("GRANITE GREY," RAL 7026).

INSTALLED IN MINUTES WITH PROVIDED FOUR (4) #10 SHEET METAL SCREWS.

PACKAGED IN A 2" HIGH BOX FOR EASY STORAGE AND TRANSPORT.

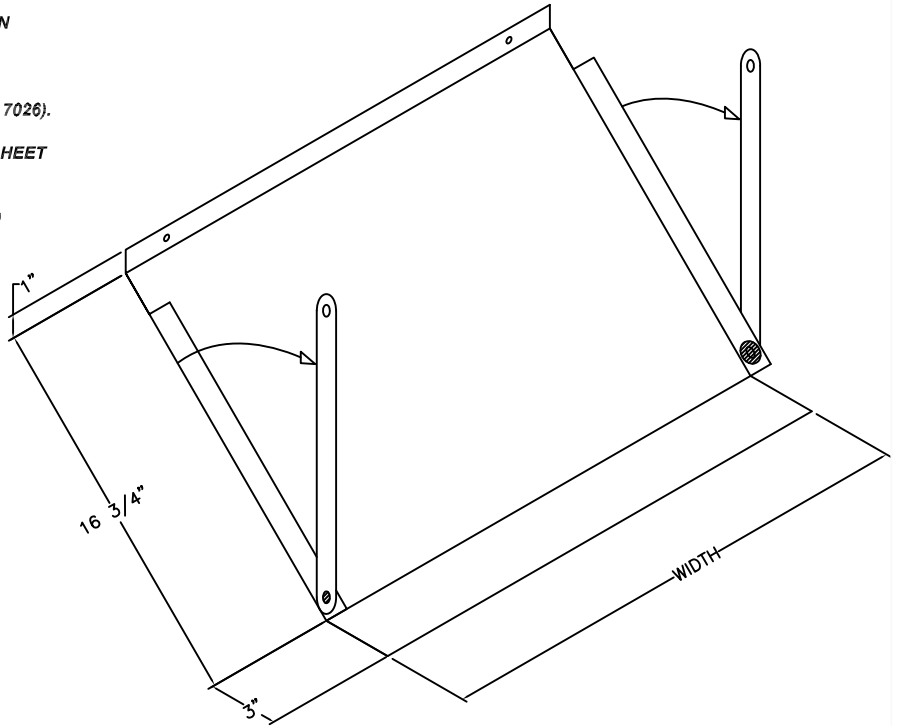
STANDARD SIZES:

MODEL	WIDTH	QTY
TASSBK175	14.75"	1
TASSBK215	18.75"	1
TASSBK235	20.75"	1

JOB NAME:
LOCATION:
ARCHITECT:
ENGINEER:
CONTRACTOR:
<p>CONTACT MIAMI TECH INC. FOR ADDITIONAL INFORMATION OR WITH SPECIAL REQUIREMENTS.</p> <p>3611 NW 74TH ST MIAMI, FL 33147 PHONE: 305-693-7054 FAX: 305-693-6152</p> <p>WEB: WWW.MIAMITECH.COM EMAIL: SALES@MIAMITECH.COM</p>

TASSBK

TRANE/AMERICAN STANDARD AIR HANDLER STAND
 SOUND BAFFLE KIT
 SPECIFICATION SHEET

NOTE: ALL DRAWINGS SUBJECT TO CHANGE WITHOUT PRIOR NOTICE.

DRAWN BY: AV	DATE: 11/2/11	SCALE: NOT TO SCALE	DRAWING NO. TASSBK
CHECKED BY: IV	DATE:	REVISION A	