



STANDARD CONSTRUCTION

BODY:

4"-10" 28 GAUGE
12"-20" 26 GAUGE
ASTM A-653 HOT-DIPPED
GALVANIZED STEEL

STANDARD SIZES:

DIAMETER	MODEL
4"	RSCT04
6"	RSCT06
8"	RSCT08
10"	RSCT10
12"	RSCT12
14"	RSCT14

DIAMETER	W/ SCOOP
4"	RSCTZ04
6"	RSCTZ06
8"	RSCTZ08
10"	RSCTZ10
12"	RSCTZ12
14"	RSCTZ14

DIAMETER	W/ DAMPER
4"	RSCTD04
6"	RSCTD06
8"	RSCTD08
10"	RSCTD10
12"	RSCTD12
14"	RSCTD14

DIAMETER	W/ SCOOP AND DAMPER
4"	RSCTZD04
6"	RSCTZD06
8"	RSCTZD08
10"	RSCTZD10
12"	RSCTZD12
14"	RSCTZD14

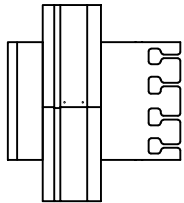

RSCT

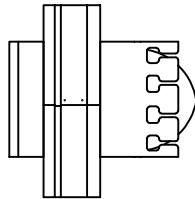

RSCTZ

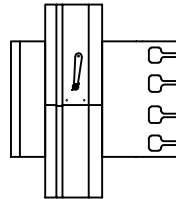

RSCTD

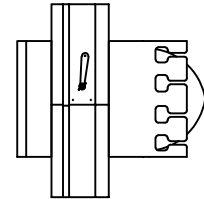

RSCTZD

FEATURES

BODY MECHANICALLY FASTENED TOGETHER TO ENSURE A RIGID ASSEMBLY.

OPTIONS:

AVAILABLE WITH DAMPER (MODEL RSCTDXX)
AVAILABLE WITH SCOOP (MODEL RSCTZXX)
AVAILABLE WITH SCOOP & DAMPER (MODEL RSCTZDXX)
CUSTOM SIZES AVAILABLE.

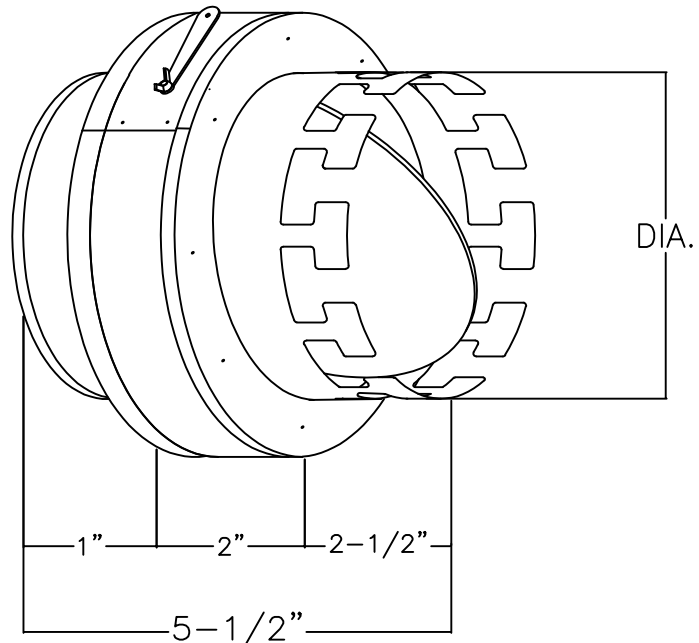

JOB NAME:
LOCATION:
ARCHITECT:
ENGINEER:
CONTRACTOR:
CONTACT MIAMI TECH INC. FOR ADDITIONAL INFORMATION OR WITH SPECIAL REQUIREMENTS.
3611 NW 74TH ST MIAMI, FL 33147 PHONE: 305-693-7054 FAX: 305-693-6152
WEB: WWW.MIAMITECH.COM EMAIL: SALES@MIAMITECH.COM

RSCT

RING SEAL COLLAR WITH TAB
PRODUCT SPECIFICATIONS

NOTE: ALL DRAWINGS SUBJECT TO CHANGE WITHOUT PRIOR NOTICE.



DRAWN BY: MR	DATE: 5/4/20	SCALE: NOT TO SCALE	DRAWING NO. RSCT
CHECKED BY: IG	DATE: 5/4/20	REVISION: 8/12/21	