

STANDARD CONSTRUCTION

BODY:
 26 GAUGE GALVANIZED STEEL
 INSULATED WITH R8 BLACK FIBERGLASS DIFFUSER BOARD

OPTIONS:
 CUSTOM SIZES AVAILABLE

STANDARD SIZES:

MODEL (R8 FIBERGLASS BOARD)	W X H
R8 SBF0804	8"X4"
R8 SBF0808	8"X8"
R8 SBF1008	10"X8"
R8 SBF1010	10"X10"
R8 SBF1206	12"X6"
R8 SBF1208	12"X8"
R8 SBF1212	12"X12"
R8 SBF1406	14"X6"
R8 SBF1408	14"X8"

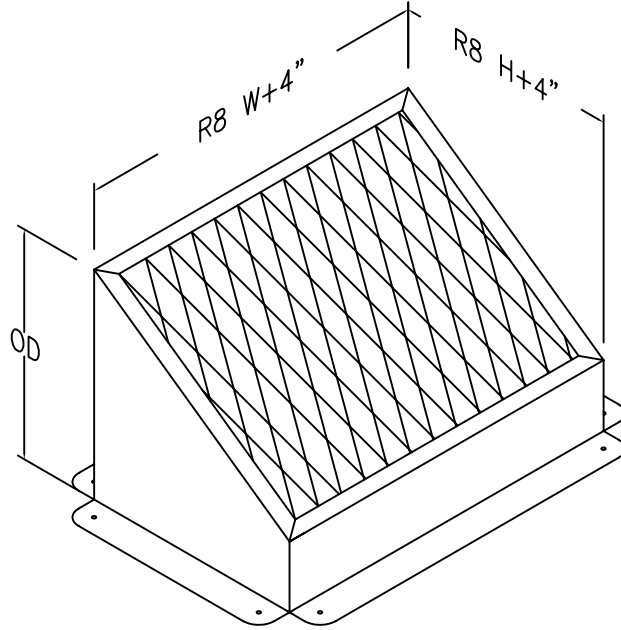
FEATURES

26 GAUGE GALVANIZED STEEL PROVIDES EXCELLENT CORROSION RESISTANCE AND LONGEVITY.

FULLY INSULATED BODY.

RIVETED SEAMS FOR ADDED STRENGTH.

AVAILABLE AS AN UNFLANGED UNIT. (SBU)

FIBERBOARD BACKED REGISTER BOXES CAN BE EASILY FIELD CUT TO FIT A VARIETY OF COLLAR SIZES.

BLACK DIFFUSER BOARD COATED WITH EPA-REGISTERED, ANTI-MICROBIAL, PROTECTIVE ACRYLIC AGENT ALONG AIR STREAM SIDE.

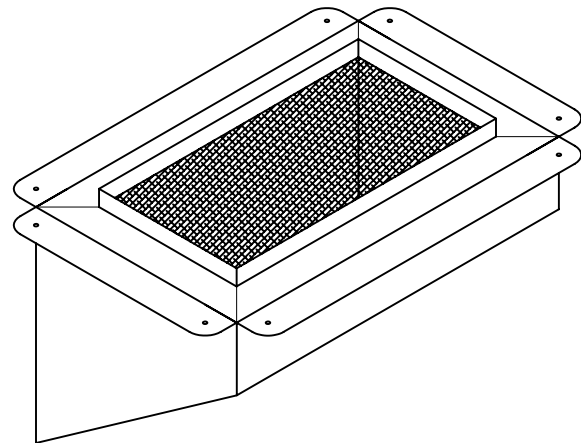
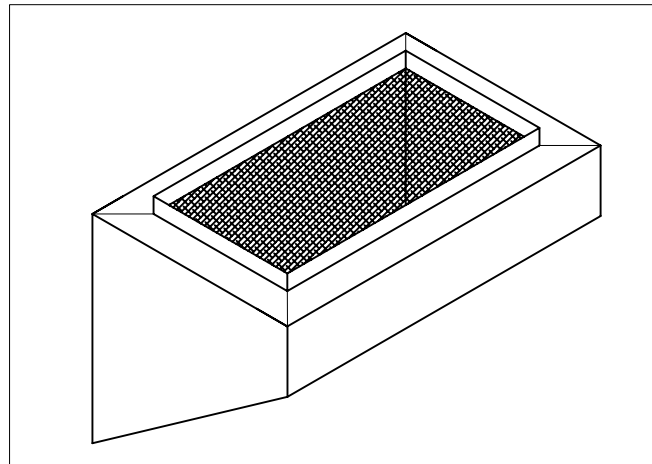
R8SBU

JOB NAME:
LOCATION:
ARCHITECT:
ENGINEER:
CONTRACTOR:
<p>CONTACT MIAMI TECH INC. FOR ADDITIONAL INFORMATION OR WITH SPECIAL REQUIREMENTS.</p> <p>3611 NW 74TH ST MIAMI, FL 33147 PHONE: 305-693-7054 FAX: 305-693-6152</p> <p>WEB: WWW.MIAMITECH.COM EMAIL: SALES@MIAMITECH.COM</p>

R8SBF

FIBERGLASS BACKED
 FLANGED SLANTED REGISTER BOX
 PRODUCT SPECIFICATIONS

NOTE: ALL DRAWINGS SUBJECT TO CHANGE WITHOUT PRIOR NOTICE.

DRAWN BY: AF	DATE: 01/06/2009	SCALE: NOT TO SCALE	DRAWING NO. R8SBF
CHECKED BY: IV	DATE: 01/06/2009	REVISION: 01	