



STANDARD CONSTRUCTION

BODY:
30 GAUGE HOT-DIPPED GALVANIZED STEEL

PERIMETER FLANGE:
30 GAUGE HOT DIPPED GALVANIZED STEEL

COLLAR:
30 GAUGE HOT DIPPED GALVANIZED STEEL

INSULATION:
R4.2,R6 OR R8 BLACK DIFFUSER BOARD AVAILABLE

OPTIONS

R4/R6/R8BF: WITHOUT COLLAR
 R4/R6/R8BFU: WITHOUT FLANGE
 R4/R6/R8BCG: WITH GASKET
 CUSTOM SIZES AVAILABLE

STANDARD SIZES:

W x H x D
6" x 4" x 4"
6" x 4" x 5"
6" x 6" x 4"
6" x 6" x 6"
8" x 4" x 4"
8" x 4" x 5"
8" x 4" x 6"
8" x 6" x 5"
8" x 6" x 6"
8" x 6" x 7"
8" x 6" x 8"
8" x 8" x 7"
8" x 8" x 8"
10" x 6" x 5"
10" x 6" x 6"
10" x 6" x 7"
10" x 8" x 7"
10" x 8" x 8"
12" x 6" x 6"
12" x 6" x 8"
12" x 12" x 8"
14" x 6" x 6"
14" x 8" x 8"
14" x 14" x 10"

FEATURES

1" PERIMETER FLANGE PROVIDED FOR EASY INSTALLATION.

DESIGN INCLUDES 1/2" DRYWALL LIP AND ROUNDED CORNERS FOR ADDED SAFETY.

OPENING 1/4" OVERSIZED TO ACCOMMODATE REGISTER/GRILLE.

COLLAR INSTALLED WITH EXPANSION LOCK AND THEN SEALED AIR TIGHT WITH HOT MELT GLUE.

DUAL BEAD BOX DESIGN FOR ADDED STRENGTH.

BLACK DIFFUSER BOARD COATED WITH EPA-REGISTERED, ANTI-MICROBIAL, PROTECTIVE ACRYLIC AGENT ALONG AIR STREAM SIDE.

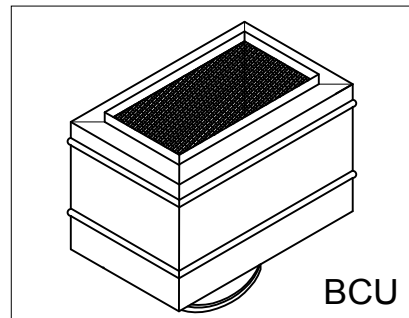
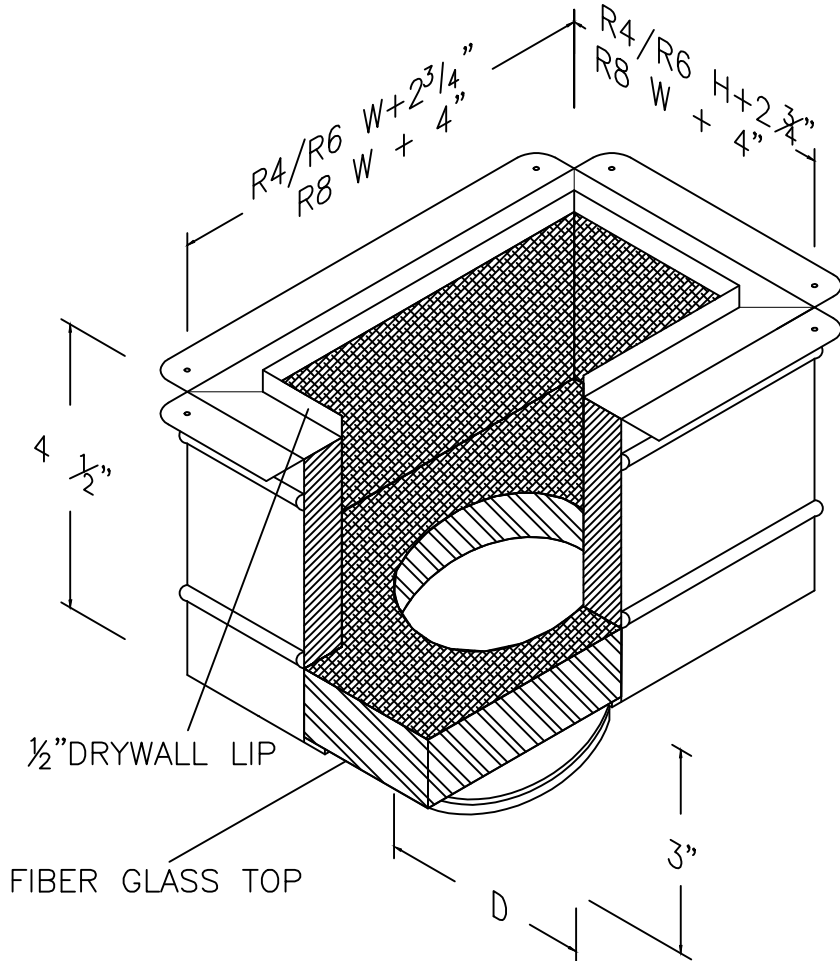

JOB NAME: _____

LOCATION: _____

ARCHITECT: _____

ENGINEER: _____

CONTRACTOR: _____

CONTACT MIAMI TECH INC. FOR ADDITIONAL INFORMATION OR WITH SPECIAL REQUIREMENTS.

3611 NW 74TH ST
 MIAMI, FL 33147
 PHONE: 305-693-7054 FAX: 305-693-6152

WEB: WWW.MIAMITECH.COM
 EMAIL: SALES@MIAMITECH.COM

R4/R6/R8BC
 FLANGED FIBERGLASS TOP
 REGISTER BOX WITH COLLAR
 PRODUCT SPECIFICATIONS

NOTE: ALL DRAWINGS SUBJECT TO CHANGE WITHOUT PRIOR NOTICE.



DRAWN BY: CG	DATE: 02/01/2009	SCALE: NOT TO SCALE	DRAWING NO. R4R6R8BC
CHECKED BY: IV	DATE: 05/19/2016	REVISION: 2	