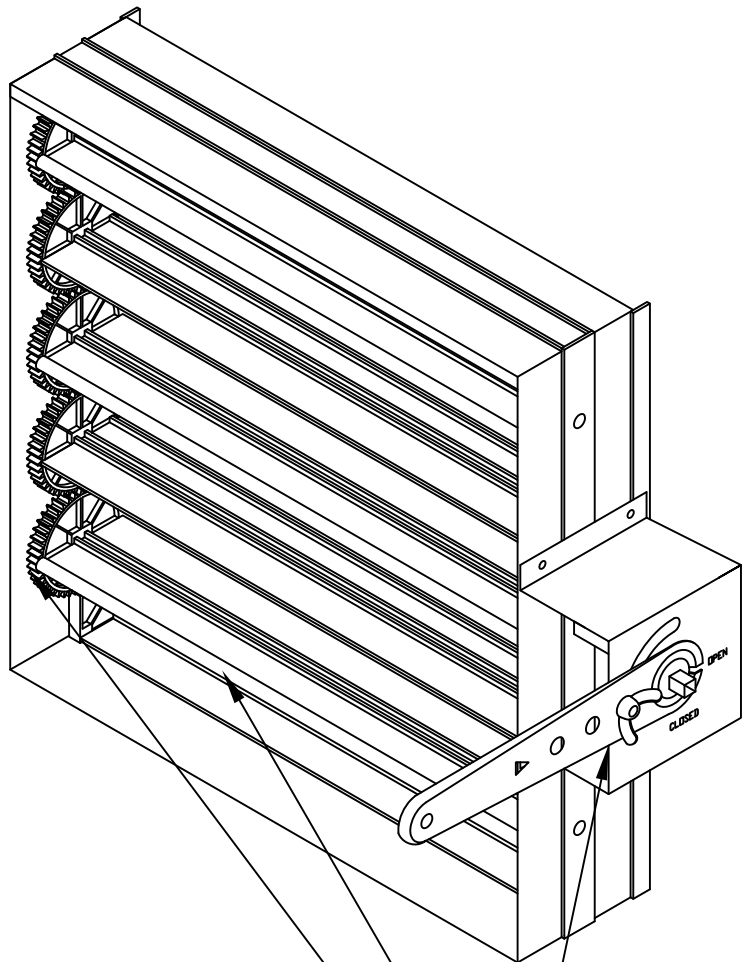

STANDARD CONSTRUCTION
MATERIAL:
**BODY AND BLADES: 6063T5 ALUMINUM
EXTRUSION**
GASKET: VINYL GASKET EXTRUSION
**GEARS: 2" ROUND GLASS-FILLED
FIRE-RETARDANT NYLON**
**2" HEAVY-DUTY STANDOFF WITH 3/8"
SQUARE ALUMINUM AXLE**
MINIMUM SIZE: 6X6"
MAXIMUM SIZE: 20X30"
FEATURES
**THE OBDS IS AN ADJUSTABLE VOLUME
DAMPER DESIGNED TO RETROFIT TO
EXISTING DUCTWORK.**
**EXTRUDED ALUMINUM PROVIDES
EXCELLENT CORROSION RESISTANCE
AND LONGEVITY.**
**BLADE EDGE RUBBER GASKET TO
REDUCE LEAKAGE WHEN DAMPER IS
CLOSED.**
OPTIONS:
**OBDS MOUNTING PLATE FOR
INSTALLATION INTO FIBERGLASS DUCT.**
CUSTOM SIZES AVAILABLE.

 QUADRANT OPERATOR
(FIELD INSTALLED)

VINYL GASKET

2" NYLON GEARS

JOB NAME:
LOCATION:
ARCHITECT:
ENGINEER:
CONTRACTOR:
CONTACT MIAMI TECH INC. FOR ADDITIONAL INFORMATION OR WITH SPECIAL REQUIREMENTS.
3611 NW 74TH ST MIAMI, FL 33147 PHONE: 305-693-7054 FAX: 305-693-6152
WEB: WWW.MIAMITECH.COM EMAIL: SALES@MIAMITECH.COM

OBDSXX
**Slim Aluminum Opposed Blade Damper
PRODUCT SPECIFICATIONS**

NOTE: ALL DRAWINGS SUBJECT TO CHANGE WITHOUT PRIOR NOTICE.

DRAWN BY: AV	DATE: 4/29/13	SCALE: NOT TO SCALE	DRAWING NO. OBDS
CHECKED BY: IV	DATE:	REVISION: 1	