



**STANDARD CONSTRUCTION**

BODY: 26 GAUGE ASTM A-653 HOT-DIPPED GALVANIZED STEEL  
COLLAR: 26 GAUGE HOT DIPPED GALVANIZED STEEL

OPTIONS:

1" FILTER TRACK SUPPORT

CUSTOM SIZES AVAILABLE

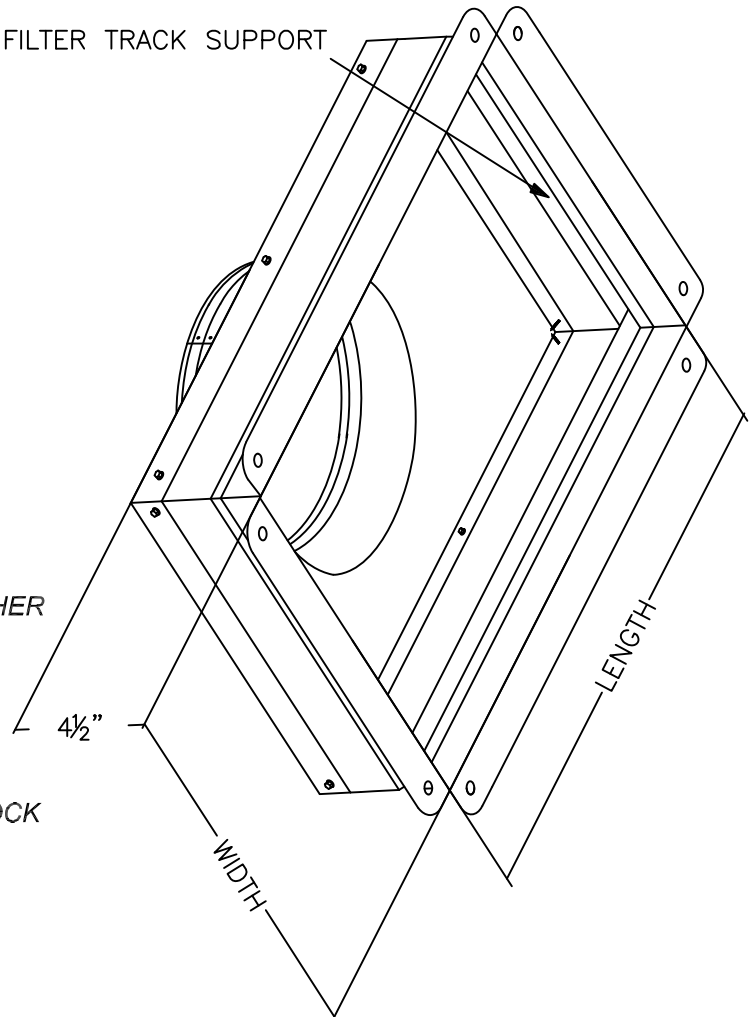

**FEATURES**

*BODY MECHANICALLY FASTENED TOGETHER TO INSURE A RIGID ASSEMBLY.*

*1" PERIMETER FLANGE FOR EASY INSTALATION*

*COLLAR INSTALLED WITH EXPANSION LOCK AND THEN SEALED AIR TIGHT*

*DUAL BEAD BOX DESIGN FOR ADDED STRENGTH*

JOB NAME:
LOCATION:
ARCHITECT:
ENGINEER:
CONTRACTOR:
CONTACT MIAMI TECH INC. FOR ADDITIONAL INFORMATION OR WITH SPECIAL REQUIREMENTS. 3611 NW 74TH ST MIAMI, FL 33147 PHONE: 305-693-7054 FAX: 305-693-6152 WEB: WWW.MIAMITECH.COM EMAIL: SALES@MIAMITECH.COM

**STANDARD SIZES:**

MODEL	DIMENSIONS (W X L X D)
MHRS142012	14"x20"x12"
MHRS142014	14"x20"x14"

**MHRS (SHORT)  
SHORT MOBILE HOME RETURN BOX  
PRODUCT SPECIFICATIONS**

NOTE: ALL DRAWINGS SUBJECT TO CHANGE WITHOUT PRIOR NOTICE.



DRAWN BY: CG	DATE: 02/26/2014	SCALE: NOT TO SCALE	DRAWING NO. MHRS
CHECKED BY: IV	DATE: 02/26/2014	REVISION: 02	