

STANDARD CONSTRUCTION

26 GAUGE ASTM A-653 HOT -DIPPED GALVANIZED STEEL

COLLAR: 26 GAUGE HOT DIPPED GALVANIZED STEEL

INSULATION:
1"-R4 BLACK DIFFUSER BOARD

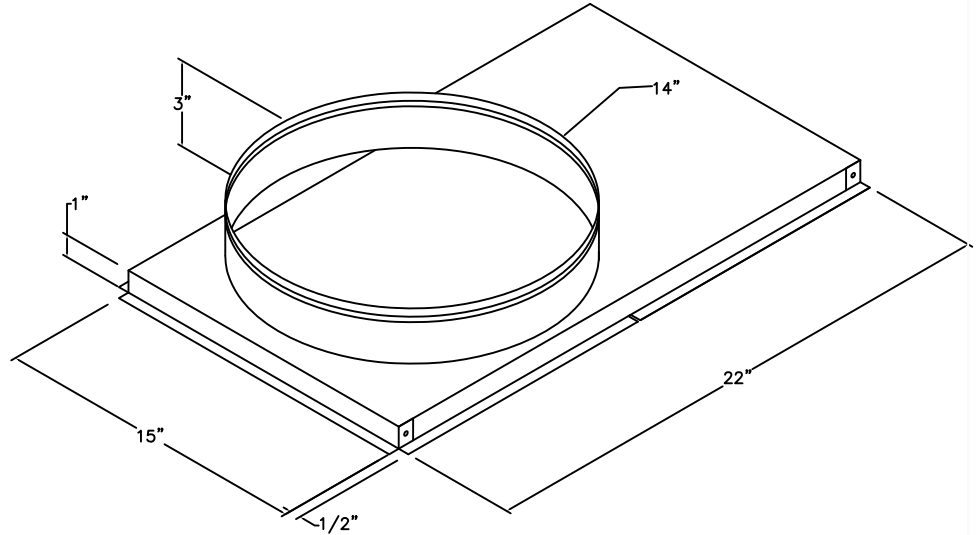

FEATURES

COLLAR INSTALLED WITH EXPANSION LOCK AND THEN SEALED AIR TIGHT WITH PARABOND ALUMINUM ADHESIVE

BLACK DIFFUSER BOARD COATED WITH EPA-REGISTERED, ANTI-MICROBIAL, PROTECTIVE ACRYLIC AGENT ALONG AIR STREAM SIDE.

SAME APPLICATION AS COMPETITIVE MODEL "667ICP"

JOB NAME:
LOCATION:
ARCHITECT:
ENGINEER:
CONTRACTOR:
<p>CONTACT MIAMI TECH INC. FOR ADDITIONAL INFORMATION OR WITH SPECIAL REQUIREMENTS.</p> <p>3611 NW 74TH ST MIAMI, FL 33147 PHONE: 305-693-7054 FAX: 305-693-6152</p> <p>WEB: WWW.MIAMITECH.COM EMAIL: SALES@MIAMITECH.COM</p>

ICPTCPU152214F

**ICP TAKEOFF COLLAR FOR PACKAGE-UNIT
PRODUCT SPECIFICATIONS**

NOTE: ALL DRAWINGS SUBJECT TO CHANGE WITHOUT PRIOR NOTICE.

<table border="1"> <tr> <td>DRAWN BY: AV</td> <td>DATE: 5-14-2013</td> <td>SCALE: NOT TO SCALE</td> <td>DRAWING NO. ICPTCPUF</td> </tr> <tr> <td>CHECKED BY: IV</td> <td>DATE:</td> <td>REVISION: A</td> <td></td> </tr> </table>	DRAWN BY: AV	DATE: 5-14-2013	SCALE: NOT TO SCALE	DRAWING NO. ICPTCPUF	CHECKED BY: IV	DATE:	REVISION: A	
DRAWN BY: AV	DATE: 5-14-2013	SCALE: NOT TO SCALE	DRAWING NO. ICPTCPUF					
CHECKED BY: IV	DATE:	REVISION: A						