

**STANDARD CONSTRUCTION**

26 GAUGE ASTM A-653 HOT -DIPPED GALVANIZED STEEL

COLLAR: 26 GAUGE HOT DIPPED GALVANIZED STEEL

INSULATION:  
1"-R4 BLACK DIFFUSER BOARD

PARABOND SEALER

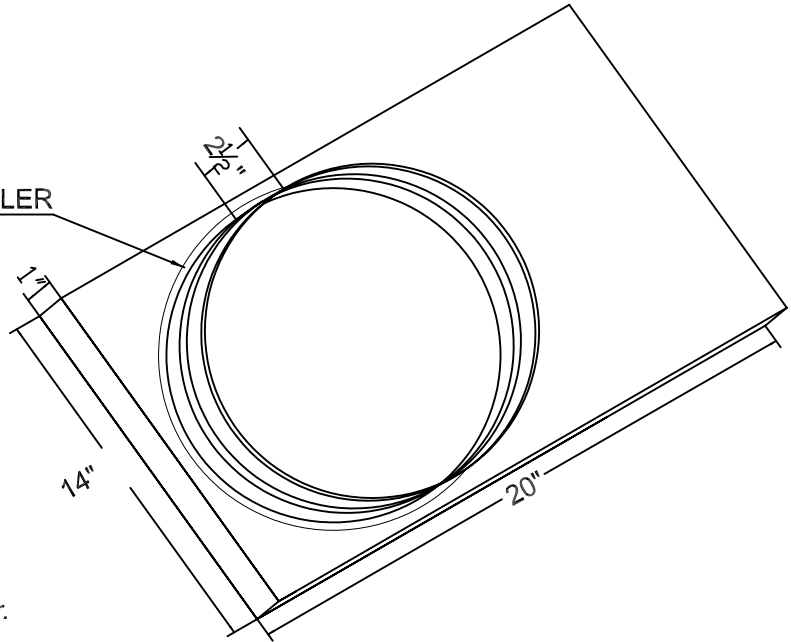

**STANDARD SIZE:**

14" Wide x 20 Long x 1" Tall. 14" Collar.

**FEATURES**

COLLAR INSTALLED WITH EXPANSION LOCK AND THEN SEALED AIR TIGHT WITH PARABOND ALUMINUM ADHESIVE

BLACK DIFFUSER BOARD COATED WITH EPA-REGISTERED, ANTI-MICROBIAL, PROTECTIVE ACRYLIC AGENT ALONG AIR STREAM SIDE. SOLD INDIVIDUALLY.

JOB NAME:
LOCATION:
ARCHITECT:
ENGINEER:
CONTRACTOR:
<p>CONTACT MIAMI TECH INC. FOR ADDITIONAL INFORMATION OR WITH SPECIAL REQUIREMENTS.</p> <p>3611 NW 74TH ST MIAMI, FL 33147 PHONE: 305-693-7054 FAX: 305-693-6152</p> <p>WEB: WWW.MIAMITECH.COM EMAIL: SALES@MIAMITECH.COM</p>

**ICPTCPU14**

ICP TAKE-OFF COLLAR FOR PACKAGE-UNIT

PRODUCT SPECIFICATIONS

NOTE: ALL DRAWINGS SUBJECT TO CHANGE WITHOUT PRIOR NOTICE.

DRAWN BY: AV	DATE: 06/04/2010	SCALE: NOT TO SCALE	DRAWING NO. ICPTCPU
CHECKED BY: IV	DATE: 06/04/2010	REVISION: 01	