

**PARTS:**

1. DOOR  
(24 GAUGE ASTM A-653 HOT-DIPPED GALVANIZED STEEL SHEET)
2. HINGE (USED ON FSA115 FAMILY ONLY)
3. CAM
4. FRAME  
(24 GAUGE ASTM A-653 HOT-DIPPED GALVANIZED STEEL SHEET)
5. 1 - 1/2" WIDE NEOPRENE FOAM GASKET
6. CAMLOCK
7. MOUNTING HOLES
8. 1 1/2" WIDE DOUBLE BACKED ADHEASIVE GASKET
9. DOOR TETHER CHAIN

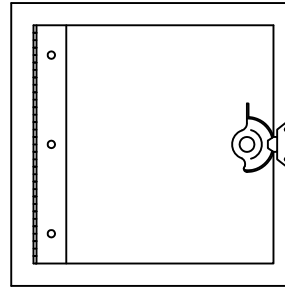

FSA125SM: HINGED DOOR

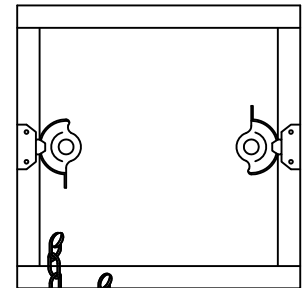

FSA126SM: CAMLOCK DOOR

**FEATURES:**

6" X 6" MINIMUM / 24" X 24" MAXIMUM UNIT DIMENSIONS.

OPENING = DUCT CUTOUT IS ACTUAL LISTED SIZE.

1" THICK UL CLASSIFIED INSULATION INSIDE ACCESS DOOR.

CAMLOCK DOORS LARGER THAN 14" X 14" HAVE A MINIMUM OF 4 LOCKS.

**OPTIONS:**

CROWN FRAME WITH KNOCK-OVER TABS FOR EASY INSTALLATION IN FIBERGLASS DUCTWORK (MODEL FSASMF).

CUSTOM SIZES AVAILABLE

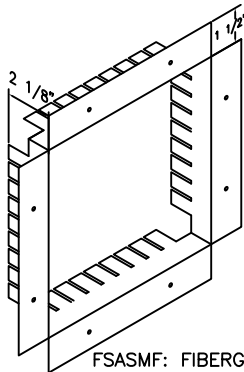
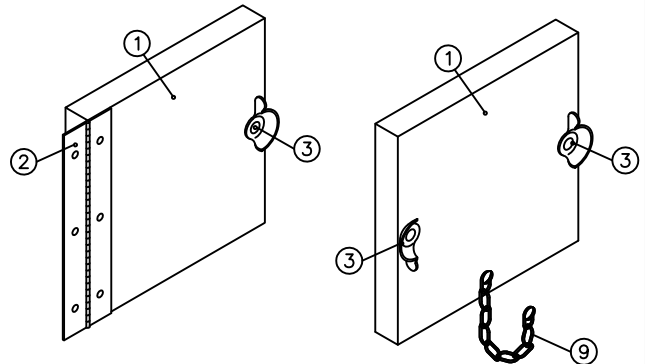

FSASMF: FIBERGLASS DUCT MOUNT FRAME

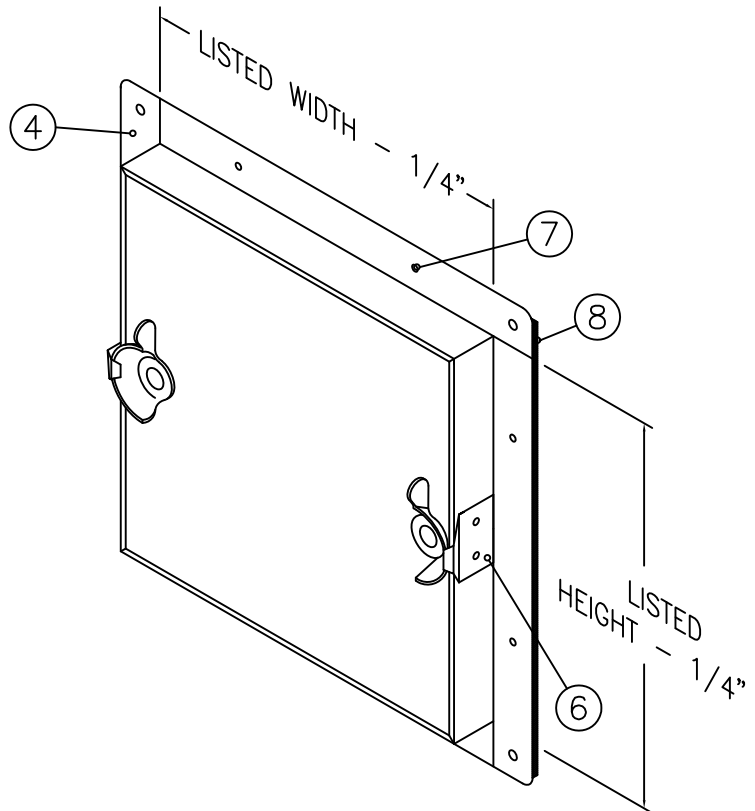

JOB NAME:
LOCATION:
ARCHITECT:
ENGINEER:
CONTRACTOR:
CONTACT MIAMI TECH INC. FOR ADDITIONAL INFORMATION OR WITH SPECIAL REQUIREMENTS.  3611 NW 74TH ST MIAMI, FL 33147 PHONE: 305-693-7054    FAX: 305-693-6152  WEB: WWW.MIAMITECH.COM EMAIL: SALES@MIAMITECH.COM

**FSA125SM / FSA126SM**

FSA125SM: HINGED ACCESS DOOR FOR METAL OR FIBERGLASS DUCT - SURFACE MOUNT

FSA126SM: CAMLOCK ACCESS DOOR FOR METAL OR FIBERGLASS DUCT - SURFACE MOUNT

**PRODUCT SPECIFICATIONS**

NOTE: ALL DRAWINGS SUBJECT TO CHANGE WITHOUT PRIOR NOTICE.

DRAWN BY: AV	DATE: 2/29/2012	SCALE: NOT TO SCALE	DRAWING NO. FSA125SM/ FSA126SM
CHECKED BY: IG	DATE:	REVISION: 1	