



STANDARD CONSTRUCTION

BODY:
14 GAUGE ASTM A-653 HOT-DIPPED GALVANIZED STEEL SHEET

STANDARD SIZES:

N: Adjusts from 14" to 25"
W: Adjusts from 17" to 27"

Part No.	Filter Track	Depth	Quantity
FR1N	1"	22"	1
FR1W	1"	22"	1
FR2N	2"	22"	1
FR2W	2"	22"	1

FEATURES

14 GAUGE GALVANIZED STEEL PROVIDES EXCELLENT CORROSION RESISTANCE AND LONGEVITY.

WELDED CONSTRUCTION FOR ADDED STRENGTH.

PRE-PUNCHED HOLES FOR EASY FASTENING TO AIR HANDLER OR BASE.

RUBBER STRIPS INCLUDED TO MINIMIZE VIBRATION.

OPTIONS: CUSTOM SIZES AVAILABLE.

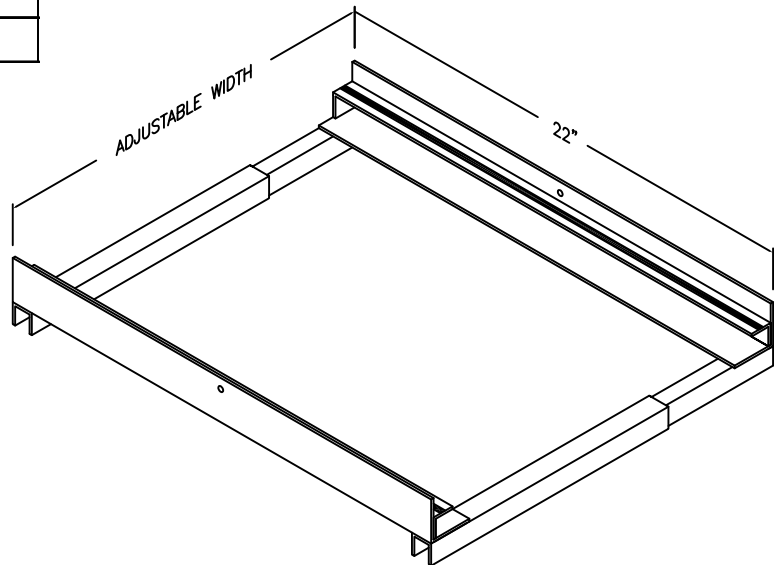

JOB NAME:
LOCATION:
ARCHITECT:
ENGINEER:
CONTRACTOR:
CONTACT MIAMI TECH INC. FOR ADDITIONAL INFORMATION OR WITH SPECIAL REQUIREMENTS. 3611 NW 74TH ST MIAMI, FL 33147 PHONE: 305-693-7054 FAX: 305-693-6152 WEB: WWW.MIAMITECH.COM EMAIL: SALES@MIAMITECH.COM

FR

**ADJUSTABLE FILTER RACK
PRODUCT SPECIFICATIONS**

NOTE: ALL DRAWINGS SUBJECT TO CHANGE WITHOUT PRIOR NOTICE.



DRAWN BY: AF	DATE: 10/10/07	SCALE: NOT TO SCALE	DRAWING NO.
CHECKED BY: IG	DATE: 5/29/14	REVISION: B	

FR