

Florida Statewide Product Approval (FSA) # FL 47101.2
Engineering Express Project # 24-74123
THIS DOCUMENT CONTAINS (12) PAGES.

EVALUATION SUBJECT: **TGM 18 SEER DUAL CAPACITY SERIES CONDENSING UNITS**

FL # 47101.2

REPORT HOLDER:

REFRICENTER OF MIAMI, INC.
7101 NW 43RD STREET
MIAMI, FL, 33166, USA
(786) 363-5755 | REFRICENTER.NET



SCOPE OF EVALUATION (compliance with the following codes):

THIS IS A STRUCTURAL (WIND) PERFORMANCE EVALUATION ONLY. NO ELECTRICAL OR TEMPERATURE PERFORMANCE RATINGS OR CERTIFICATIONS ARE OFFERED OR IMPLIED HEREIN. UNDER NO CIRCUMSTANCE DOES THIS PERFORMANCE EVALUATION GUARANTEE, IMPLY, OR STATE PERFORMANCE OF THE UNIT IS MAINTAINED DURING OR AFTER A DESIGN EVENT.

This Performance Evaluation is being issued in accordance with the requirements of the **Florida Building Code Eighth Edition (2023)** per ASCE 7, FBC Building Ch. 16, FBC Building Sections 104.11 & 1522.2, FBC Existing Building Sections 707.1 & 707.2, FBC Mechanical 301.15, FBC Residential M1202.1 & M1301.1, and FS 471.025. The product noted in this performance evaluation has been tested and/or evaluated as summarized herein.

SUBSTANTIATING DATA:

• Product Evaluation Documents

Substantiating documentation has been submitted to provide this performance evaluation and is summarized in the sections below.

• Structural Engineering Calculations

Structural engineering calculations have been prepared which evaluate the product based on comparative and/or rational analysis to qualify the following design criteria:

- Max. allowable (ASD) lateral & uplift wind pressures certified herein
- Max. allowable sliding forces, uplift forces, & overturning moments (see Unit Reactions from Wind Guide on last page)
- Tie-down configuration and anchor capacity for concrete, aluminum, and steel host substrates (host by others).
- Unit panel wind pressure connection integrity

Calculation summary is included in this product evaluation and appears herein.

LIMITATIONS & CONDITIONS OF USE:

Use of the product(s) listed herein shall be in strict accordance with this product evaluation as noted herein and manufacturer-provided model specifications. Installation shall conform to the minimum standards stated in the referenced building code(s) in addition to the specifications and limitations stated herein. See herein for complete limitations & conditions of use.

OPTIONS:

This evaluation is valid for the models described herein. The critical unit designs have been determined and used in this evaluation. Any structural changes outside of the design as described herein would void this certification.

UNIT CASING MATERIALS:

Exterior panels, unit base, and integrated feet/legs shall be constructed of UTS = 36 ksi min. (or 250 MPa min.) galv. steel. Exterior panels shall be 22 GA min. thick. Unit base and integrated feet/legs shall be 20 GA min. thick. Exterior panels shall be secured with #8 (0.164") min. Ø, SAE Gr. 2 min. or SS sheet metal screws. Contact Report Holder for further unit construction information.

TERMINOLOGY:

See herein for definitions of terms and abbreviations used in this evaluation.



NOTE: THE GRAPHICAL DEPICTIONS IN THIS EVALUATION ARE FOR ILLUSTRATIVE PURPOSES ONLY AND MAY DIFFER IN APPEARANCE.

STRUCTURAL PERFORMANCE:

Models referenced herein are subject to the following design limitations:

**Maximum-Rated ASD Wind Pressures*:
± 140 psf Lateral, 111 psf Uplift**

- Required design wind pressures shall be determined according to the guide provided in the Appendix (see last page of this document) or on a site-specific basis in accordance with ASCE 7 and applicable sections of the building code(s) being referenced in accordance with ASD methodology.
- Required design wind pressures shall be less than or equal to the maximum pressures listed herein.
- *Maximum Rated Wind Pressures indicate the maximum pressures that all units listed herein are approved for. Valid for at-grade, wall-mounted, and rooftop applications. See limitations herein.
- Valid for use inside and outside the High-Velocity Hurricane Zone (HVHZ).
- Site-specific wind analysis may produce alternate limitations provided that the maximum-rated wind pressures stated herein are not exceeded.

VISIT [ECALC.IO/74123](https://ecalculator.io/74123)

FOR MORE INFORMATION AND DEVIATIONS TO THIS EVALUATION OR SCAN THE QR CODE TO THE RIGHT >



Engineer Signature & Seal:

October 24, 2024

Richard Neet, P.E.

ENGINEERING EXPRESS®

FL PE #86488 FLCA #9885

*PRINTED COPIES OF THIS DOCUMENT ARE NOT CONSIDERED SIGNED & SEALED. SIGNATURE MUST BE VERIFIED ON ANY ELECTRONIC COPIES.
***FOR FLORIDA STATEWIDE PRODUCT APPROVALS (FSAs) REGISTERED & APPROVED WITH THE STATE OF FLORIDA:** ORIGINAL, SEALED COPIES OF APPROVED FLORIDA PRODUCT APPROVALS ARE NOT REQUIRED FOR PERMIT. SEE [ECALC.IO/SEAL](https://ecalculator.io/SEAL) TO LEARN MORE.

MODEL INFORMATION (Continued on Following Pages)

Model Number	Cabinet Group	Unit Dimensions (in) [mm]		
		Width	Depth	Height
GTS18CN036A	I	37.01 [940]	18.11 [460]	32.28 [820]
GTS18CN060A	II	37.01 [940]	12.60 [320]	56.30 [1430]
GTS18HN036A	I	37.01 [940]	18.11 [460]	32.28 [820]
GTS18HN060A	II	39.37 [1000]	14.57 [370]	53.74 [1365]
GUD36W/A-D(U)	I	37.01 [940]	18.11 [460]	32.28 [820]
GUD60W/A-D(U)	II	39.37 [1000]	14.57 [370]	53.74 [1365]
GULD36W2/A1-D(U)	I	37.01 [940]	18.11 [460]	32.28 [820]
GULD60W2/A1-D(U)	II	37.01 [940]	12.60 [320]	56.30 [1430]

MODEL INFORMATION NOTES

The model information listed herein is based on information provided by the client. Unit dimensions listed above are unit net dimensions (as opposed to gross/packing/shipping dimensions). Cabinet Groups (abbreviated as "Cab. Groups" or "Cab." as needed) are designated by Engineering Express based on the unit cabinet and panel layout. See Details 1A-1B for definitions of unit dimensions, Cabinet Groups, and panel designations (related to the Panel Integrity evaluation summarized herein). See Details 2-5 on the following page for unit integrated feet information. Unit appearance may vary. Unit net weights (as opposed to gross/packing/shipping weights) shall be as follows:

- Cabinet Group I: between 150 lb and 250 lb, typ;
- Cabinet Group II: between 240 and 340 lb, typ;

MODEL INFORMATION CONTINUED:

DETAIL 1A: CABINET GROUP I

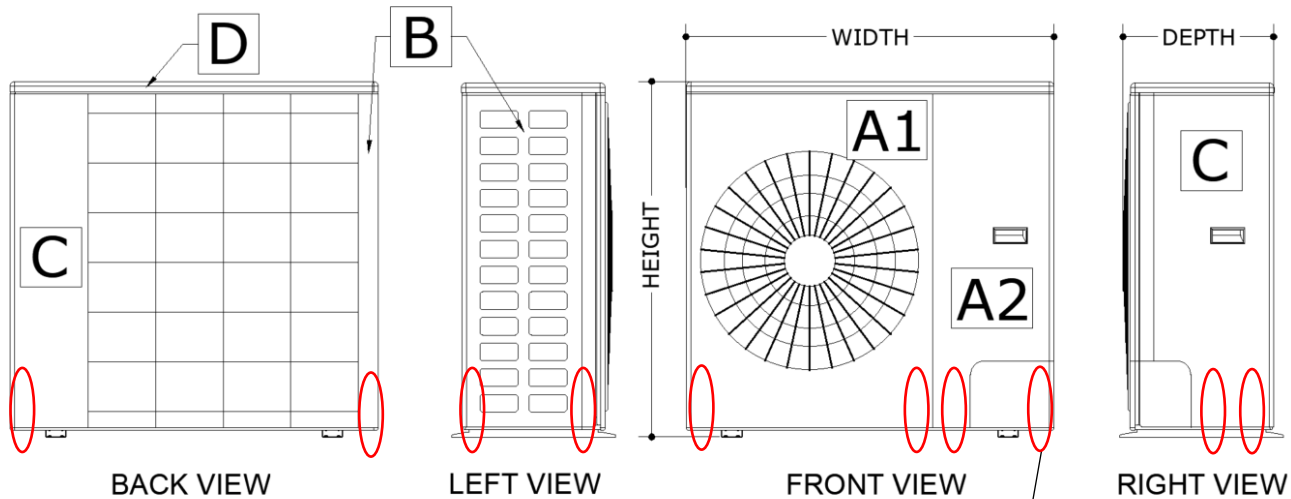

CABINET GROUP I: UNIT DIMENSIONS & PANEL DESIGNATIONS

1A

SCALE: NTS

MULTIPLE VIEWS

POSSIBLE TIE-DOWN CLIP LOCATION, TYP. SEE TIE-DOWN SCHEDULE & NOTES.

CABINET GROUP I NOTES

Panel layouts as designated above by the boxed call-outs above (e.g. "A1", "B", etc.) are as follows:
 The unit's front is composed of two solid panels, designated "A1" and "A2". Panel "A1" is defined as the front-left solid panel containing the fan. This panel bends around the front-left corner of the unit and extends slightly into the unit left side. The unit fan is protected by a fan cage (not designated above). Panel "A2" is defined as the front-right solid panel with the handle. This panel bends slightly around and into the unit's right side. The unit's right side is composed of one main panel, designated "C", that covers most of the unit's right side, bends around the right-back corner, and extends into part of the unit's back side. The remainder of the unit's back side was considered to be covered by a wire guard, exposing the coil/condenser assembly. The unit's left side is composed of a wall panel "B", which is mostly porous and exposes the coil/condenser assembly. The top panel "D" covers all side wall panels and forms the roof of the unit. The wire guard, fan cage, and any other cover panels (if applicable) were considered in the Panel Integrity analysis summarized herein but may not be specifically designated above. Unit appearance may vary slightly. See the Panel Integrity section herein.

**MODEL INFORMATION CONTINUED: (Continued on Previous/Following Pages)
DETAIL 1B: CABINET GROUP II**

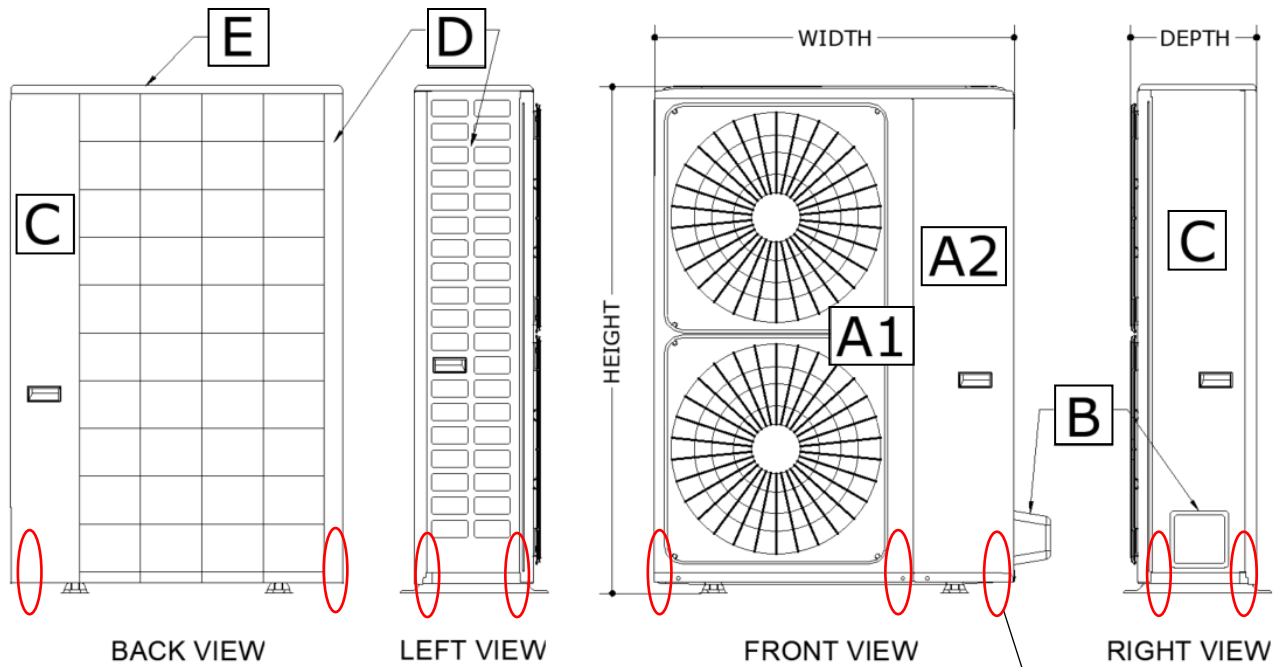

POSSIBLE TIE-DOWN CLIP LOCATION, TYP. SEE TIE-DOWN SCHEDULE & NOTES.

1B CABINET GROUP II: UNIT DIMENSIONS & PANEL DESIGNATIONS
SCALE: NTS MULTIPLE VIEWS

CABINET GROUPS II NOTES

Panel layouts as designated above by the boxed call-outs above (e.g. "A1", "B", etc.) are as follows:
The unit's front is composed of two solid panels, designated "A1" and "A2". Panel "A1" is defined as the front-left solid panel containing the fans. This panel bends around the front-left corner of the unit and extends slightly into the unit left side. The unit fan is protected by two fan cages (not designated above). Panel "A2" is defined as the front-right solid panel with the handle. This panel bends slightly around and into the unit's right side. The unit's right side is composed of one main panel, designated "C", that covers most of the unit's right side, bends around the right-back corner, and extends into part of the unit's back side. Overlying this panel "C" is a cover panel "B" for the valves and/or controls. The remainder of the unit's back side was considered to be covered by a wire guard, exposing the coil/condenser assembly. The unit's left side was considered to be composed of a main panel "D", which is mostly porous and exposes the coil/condenser assembly. The top panel "E" covers all side wall panels and forms the roof of the unit. The wire guard, fan cage, and any other cover panels (if applicable) were considered in the Panel Integrity analysis summarized herein but may not be specifically designated above. Unit appearance may vary slightly. See the Panel Integrity section herein.

REMAINDER OF PAGE INTENTIONALLY LEFT BLANK

DETAILS 2 – 5: UNIT INTEGRATED FEET

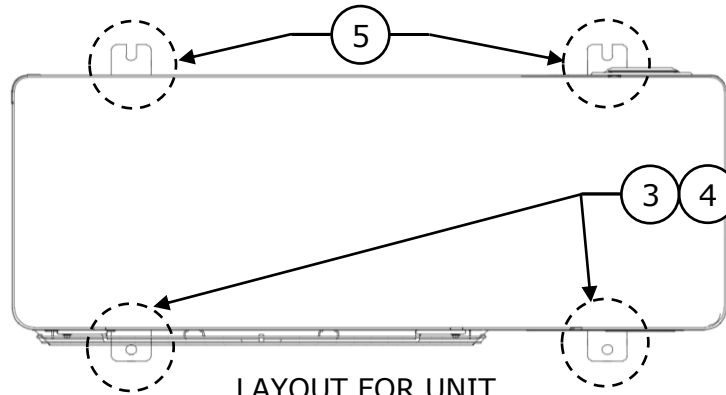

2 LAYOUT FOR UNIT INTEGRATED FEET
SCALE: NTS TOP VIEW

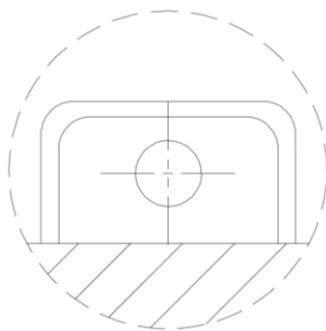

3 UNIT INTEGRATED FOOT, NO SLOT
SCALE: NTS TOP VIEW

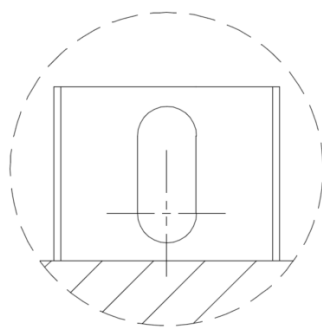

4 UNIT INTEGRATED FOOT, CLOSED SLOT
SCALE: NTS TOP VIEW

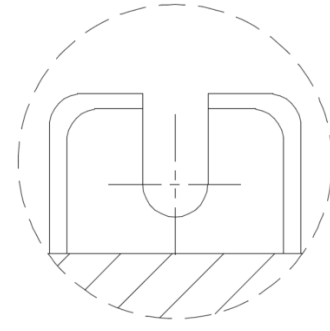

5 UNIT INTEGRATED FOOT, OPEN SLOT
SCALE: NTS TOP VIEW

DETAILS 2 – 5: UNIT INTEGRATED FEET NOTES

Fasten unit to host structure using anchors per the Tie-Down Schedule and Notes section herein. Position anchors at crosshairs shown in Details 3 - 5, typ. Details 2 - 5 are for illustrative purposes only. Unit and integrated feet may vary in appearance. All units were considered to have (2) unit integrated feet with open slots per Detail 5, and (2) fully enclosed feet, as shown in Details 3 & 4. A reverse configuration to that shown in Detail 2 is also permitted, with open-slotted feet at the unit front side and fully enclosed feet at the unit back side. It is also permitted for units to have (4) fully enclosed feet with no open slots, per Details 3 & 4.

REMAINDER OF PAGE INTENTIONALLY LEFT BLANK

TIE-DOWN SCHEDULE

Cab. Group	Install. Cond.	Max. ASD Wind Pressures Lateral (Uplift)	Anchor Schedule to Host Structure By Others			# of Tie-Down Clips	# of Tie-Down Straps
			f'c = 3 ksi min. Regular-Weight Concrete Host	12 GA min. thick UTS = 58 ksi min. Steel Host	0.090" min. thick 6061-T6 Aluminum Host		
I	Ground	± 42 psf (0 psf)	A	N/A	N/A	0	0
		± 54 psf (0 psf)	A	N/A	N/A	1	0
	Ground, Wall, Roof	± 80 psf (64 psf)	N/A	B and C	B and C	2	0
		± 110 psf (87 psf)	N/A	B and C	B and C	2	0
		± 140 psf (111 psf)	N/A	B and C	B and C	4	0
II	Ground	± 25 psf (0 psf)	A	N/A	N/A	0	0
		± 54 psf (0 psf)	A	N/A	N/A	2	0
	Ground, Wall, Roof	± 80 psf (64 psf)	N/A	B and C	B and C	4	2
		± 110 psf (87 psf)	N/A	B and C	B and C	4	4
		± 140 psf (111 psf)	N/A	B and C	B and C	6	6

TIE-DOWN SCHEDULE NOTES (Continued Next Page)

TIE-DOWN SCHEDULE DIRECTIVE: The Tie-Down Schedule table above is divided by Cabinet Group and maximum wind pressure tier (each row of the table). The typical installation condition(s) are also stated for each wind pressure tier. Site-specific wind pressures up to ± 54 psf lateral & 0 psf uplift shall use, at minimum, the tie-down specifications as stated in the ± 54 psf lateral (0 psf uplift) pressure tier row for the respective Cabinet Group* (*except for Cabinet Group II, which has an additional tier for ± 32 psf lateral (0 psf uplift)). Site-specific wind pressures that fall in-between pressure tiers shall use, at minimum, the tie-down specifications as specified by the higher pressure tier for the respective Cabinet Group. Ensure the host structure by others meets the minimum specifications as stated in the Anchor Schedule section of the table. The Tie-Down Schedule applies to all units described in this evaluation. See tie-down specifications and Details herein. Contact Engineering Express for site scenarios outside the bounds of this evaluation.

Ex. 1: Say you have a Cab. Group I unit at-grade (ground) installation, with site-specific wind pressures of ± 45 psf lateral and 0 psf uplift. In this case, you would need to follow, at minimum, the tie-down specifications corresponding to the ± 54 psf (0 psf) wind pressure tier row for Cab. Group I. This row only permits anchoring to concrete host structures. If your host structure is aluminum or steel, you would need to use, at minimum, the tie-down specifications corresponding to the ± 80 psf (64 psf) wind pressure tier row for Cab. Group I.

Ex. 2: Say you have a Cab. Group II rooftop installation, with site-specific wind pressures of ± 96 psf lateral and 76 psf uplift. In this case, you would need to follow, at minimum, the tie-down specifications corresponding to the ± 110 psf (87 psf) wind pressure tier row for Cab. Group II. This row permits aluminum and steel host structures only. Anchoring to a concrete host structure would not be permitted in this example.

ANCHOR SCHEDULE NOTES: In all cases, the host structure is by others. Anchor shall be selected per site-specific wind pressures and host structure substrate. Utilize (1) anchor per mounting hole/slot - (4) mounting holes/slots per unit. Also, utilize (1) anchor per tie-down clip. Refer to Details 2 – 5 for unit integrated feet anchor placement. Anchor specifications as represented in the Tie-Down Schedule are as follows:

- A: Anchors to Concrete Hosts for Unit Integrated Feet and Tie-Down Clips (if applicable):**
1/4" Ø ITW Tapcon or equivalent with 1-3/4" min. embedment, 3" min. edge distance to any edge of the concrete, and 3-1/4" min. spacing from neighboring concrete anchors, typ. Use (1) 1" min. OD x 0.065" min. thick fender washer sized for 1/4" Ø anchors under each anchor head, typ.
- B: Anchors to Aluminum/Steel Hosts for Unit Integrated Feet:**
3/8" Ø, SAE Gr. 5 or stronger thru-bolt with 1" min. OD x 0.065" min. thick fender washers sized for 3/8" Ø bolts top and bottom and locking nut, typ. Provide 1/2" min. edge distance to any edge of the host structure and 1" min. spacing from neighboring thru-bolts, typ.
- C: Anchors to Aluminum/Steel Hosts for Tie-Down Clips:**
1/4" Ø, SAE Gr. 5 or stronger thru-bolt with 1" min. OD x 0.065" min. thick fender washers sized for 1/4" Ø bolts top and bottom and locking nut, typ. Provide 1/2" min. edge distance to any edge of the host structure and 1" min. spacing from neighboring thru-bolts, typ.

N/A: Not applicable.

TIE-DOWN SCHEDULE NOTES CONTINUED NEXT PAGE

TIE-DOWN SCHEDULE NOTES (Continued from Previous Page)

TIE-DOWN CLIP NOTES: For Cabinet Group I at-grade installations to concrete host structures up to ± 54 psf lateral & 0 psf uplift wind pressures, tie-down clips are not required. For Cabinet Group II at-grade installations to concrete host structures up to ± 25 psf lateral & 0 psf uplift wind pressures, tie-down clips are not required.

Tie-down clips shall be 1" min. wide, 6"-10" tall, 0.068" min. thick, UTS = 45 ksi min. (equiv. to ASTM A653 Gr. 33 or stronger) galv. steel (Miami Tech CUTD per FL 19731.2). Fasten clip to host structure with (1) anchor per tie-down clip according to the "Anchor Schedule to Host Structure" specifications stated herein. Ensure the anchor is placed at the center of the tie-down clip leg to provide 1/2" min. edge distance, typ.

Fasten tie-down clip to unit with (5) #10, SAE Gr. 2 min. or SS self-drilling screws with 1/2" min. OD washers, typ. Utilize (5) tie-down clip slots that have flush, solid contact with the unit, (1) screw per slot, typ. Care must be taken to avoid screw contact with internal piping and components. Exercise caution with screw installation. Ensure all screws fully engage with the unit. Tie-down clips shall sit flush on the host structure and flush against the unit. See tie-down clip details herein.

Distribute the specified tie-down clip quantity as follows:

- For scenarios with (1) clip required, position clip at either of the unit short sides (left side or right side of the unit).
- For scenarios with (2) clips required, position (1) clip at the front side of the unit and (1) at the back side of the unit.
- For scenarios with (4) clips required, position (2) clips at the front side of the unit and (2) at the back side of the unit.
- For scenarios with (6) clips required, position (2) clips at the front side of the unit, (2) at the back side of the unit, (1) clip at the left side of the unit, and (1) clip at the right side of the unit.

See the "Model Information" section prior for suggested tie-down clip locations.

Depending on the unit's orientation when placed onto the aluminum/steel host members (i.e. stand rails or wall brackets), it may be necessary to add (2) support angles to accommodate tie-down placement. If needed, support angles shall be added as depicted in the tie-down details herein. Support angle(s) shall be L-angle(s) with the following specifications: 3" min. wide legs x 1/8" min. thick, 6061-T6 aluminum. Support angle length may vary so long as the support angle attachment conditions are achieved; see limitations herein.

Note: Miami-Tech "CAB" aluminum support angles may also be used and attached per Details 1A & 1B of Miami-Dade NOA # 21-1013.01.

- For scenarios in which the unit is oriented parallel to the host members:
Attach each support angle to the host structure members with (2) 1/4" \varnothing , SAE Gr. 5 or stronger Thru-Bolts at each end of the angle, (4) per angle. Provide 1" min. OD fender washers sized for 1/4" \varnothing bolts top and bottom and locking nut, typ. Provide 1" min. spacing between Thru-Bolts and 1/2" min. edge distance to any edge of members in contact (support angle and host structure member).
- For scenarios in which the unit is oriented perpendicularly to the host members:
 - Cabinet Group I: Attach each support angle to the host structure members with (2) 1/4" \varnothing , SAE Gr. 5 or stronger Thru-Bolts at each end of the angle, (4) per angle.
 - Cabinet Group II: Attach each support angle to the host structure members with (4) 1/4" \varnothing , SAE Gr. 5 or stronger Thru-Bolts at each end of the angle, (8) per angle.
 - For all thru-bolts specified above: Provide 1" min. OD fender washers sized for 1/4" \varnothing bolts top and bottom and locking nut, typ. Provide 1" min. spacing between Thru-Bolts and 1/2" min. edge distance to any edge of members in contact (support angle and host structure member).

TIE-DOWN STRAP NOTES: For all Cabinet Group at-grade installations to concrete host structures up to ± 54 psf lateral & 0 psf uplift wind pressures, tie-down straps are not required. For Cabinet Group I installations to aluminum and steel host structures up to ± 140 psf lateral & 111 psf uplift wind pressures, tie-down straps are not required.

Tie-down straps shall be 1" min. wide x 22 GA (.030") min. thick, UTS = 45 ksi min. (equiv. to ASTM A653 Gr. 33 or stronger) galv. steel. Wrap each tie-down strap over the long sides and top of the unit and attach each strap end to the aluminum or steel host structure members (i.e. wall brackets or roof stand rails). (See Tie-Down Details herein). Position tie-down straps 3" minimum away from the unit short side edges and provide 1/2" min. spacing between edges of adjacent straps, typ.

Attach each strap end to the host structure member with (4) #10, SAE Gr. 2 min. or SS SMS with 1/2" min. spacing between screws and 1/4" min. edge distance to any edge of strap and host structure member, typ. It is suggested that the straps attach to the undersides of the host structure members, but the straps are permitted to attach to any horizontal or vertical face of the host structure so long as all conditions stated herein are achieved. See the Tie-Down Details herein.

To prevent strap from slipping, also attach each strap to roof of unit with (2) #10 x 1/2" long, SAE Gr. 2 min. or SS SMS with 3" min. end distance from edges of roof and positioned O.C. of strap, (1) each side, typ. See Tie-Down Details herein.

Tie-down strap lengths shall be determined by the installing contractor. Ensure strap lengths are such that the strap is neither excessively taut nor excessively slack once installed. A secure fit should be achieved. Neoprene pads may be placed between the unit and the strap to protect the unit from damage/distortion. Straps may be removed for maintenance purposes but shall be replaced per the attachment directive herein following maintenance. **Tie-down straps must be in place before any named storm or similar high-wind event.**

TIE-DOWN DETAILS, 6 - 8

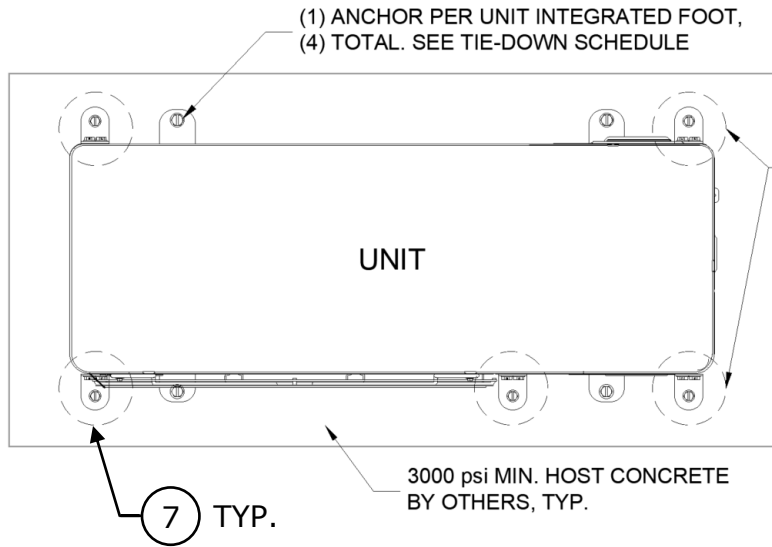

NOTE:
CERTAIN AT-GRADE
INSTALLATIONS REQUIRE
(2) TIE-DOWN CLIPS, (1)
PER LONG SIDE, PER THE
TIE-DOWN SCHEDULE &
NOTES. POSSIBLE
TIE-DOWN CLIP
LOCATIONS ARE CIRCLED;
ENSURE THE 3-1/4" MIN.
SPACING IS PROVIDED
BETWEEN TIE-DOWN CLIP
AND UNIT-INTEGRATED
FOOT ANCHORS.

6 SAMPLE TIE-DOWN LAYOUT TO CONCRETE, TYP. SCALE: NTS PLAN VIEW

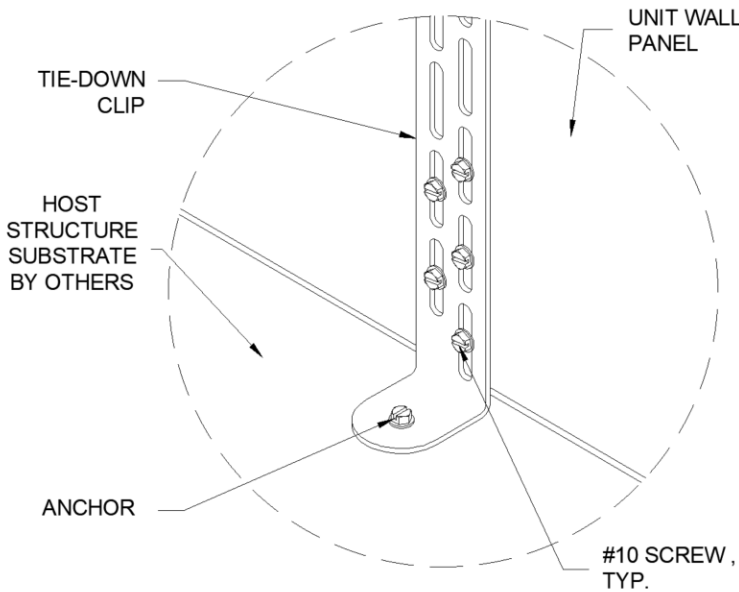

7 TIE-DOWN CLIP ATTACHMENT, TYP. SCALE: NTS ISOMETRIC VIEW

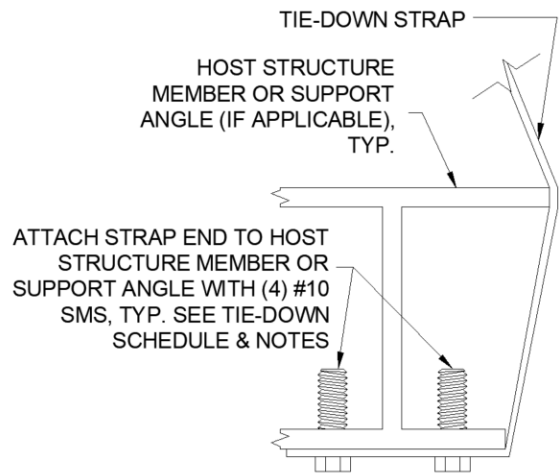

8 TIE-DOWN STRAP ATTACHMENT, TYP. SCALE: NTS ISOMETRIC VIEW

TIE-DOWN DETAILS, 6 - 8 NOTES

For each Detail in this section, consult the Tie-Down Schedule and Notes herein for all tie-down components & specifications required.

The units depicted in the Details on this page are for illustrative purposes only. Units may vary in appearance. Tie-down system may not be depicted in full. The sample tie-down layouts shown herein are for illustrative purposes only. Tie-down locations may vary per the specifications of the Tie-Down Schedule and Notes herein. Host structure shape may vary.

Detail 8 Note: it is suggested that the (4) SMS be arranged in a square configuration with 1/2" spacing and centered on tie-down strap and host structure member to provide the required 1/4" min. edge distance requirement.

TIE-DOWN DETAILS, 9 – 12

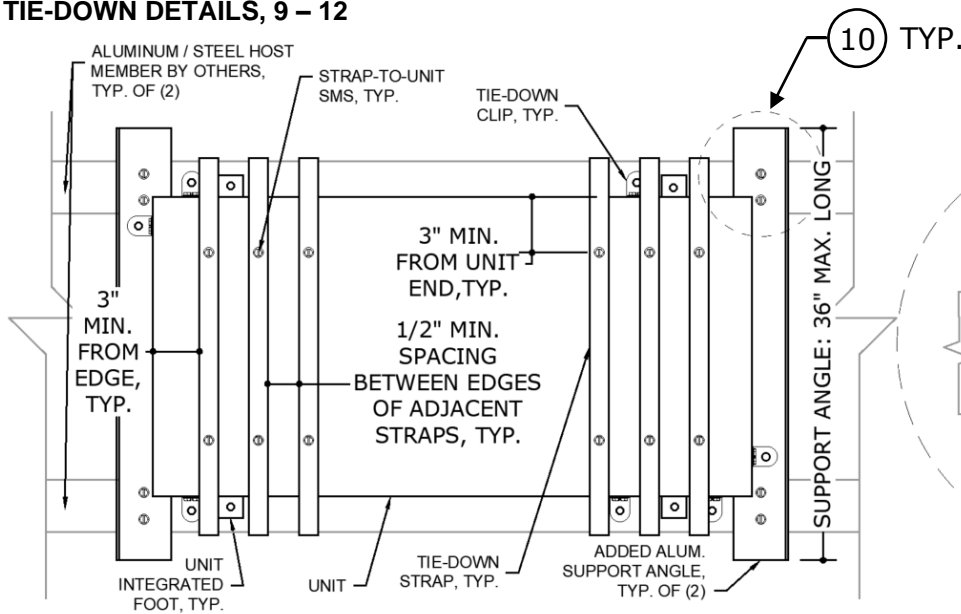

9 SAMPLE TIE-DOWN TO ALUM./STEEL HOST
SCALE: NTS TOP VIEW, UNIT || TO HOST SUPPORTS

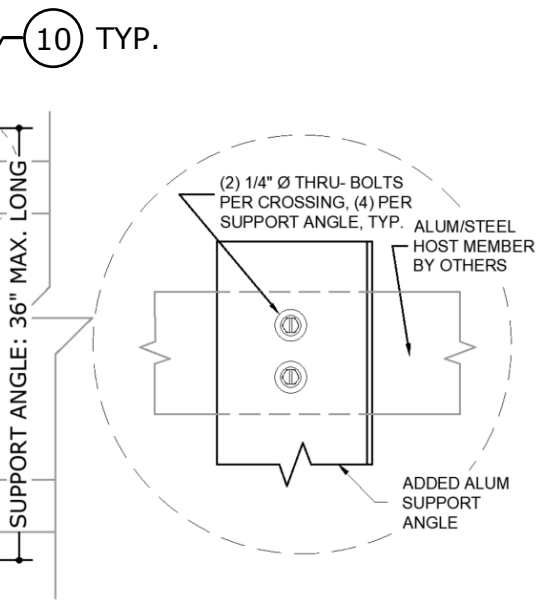

10 SUPPORT ANGLE ATTACHMENT TO ALUM/STEEL HOST, TYP.
SCALE: NTS TOP VIEW, UNIT || TO HOST

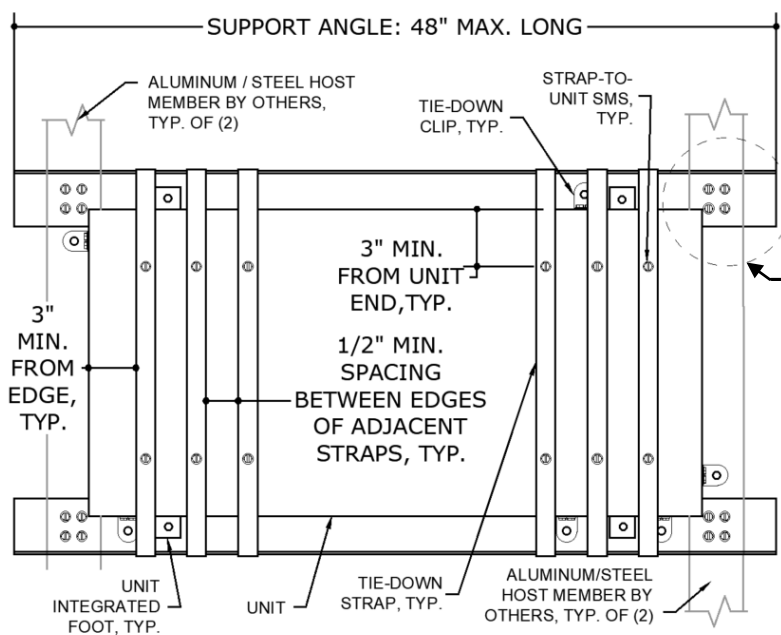

11 SAMPLE TIE-DOWN TO ALUM./STEEL HOST
SCALE: NTS TOP VIEW, UNIT ⊥ TO HOST SUPPORTS

DETAIL 12 NOTE: CABINET GROUP I MAY USE (2) 1/4" Ø THRU-BOLTS PER CROSSING WHEN UNIT IS ⊥ TO DIRECTION OF HOST MEMBERS. CABINET GROUP II SHALL USE (4) 1/4" Ø THRU-BOLTS AS SHOWN BELOW.

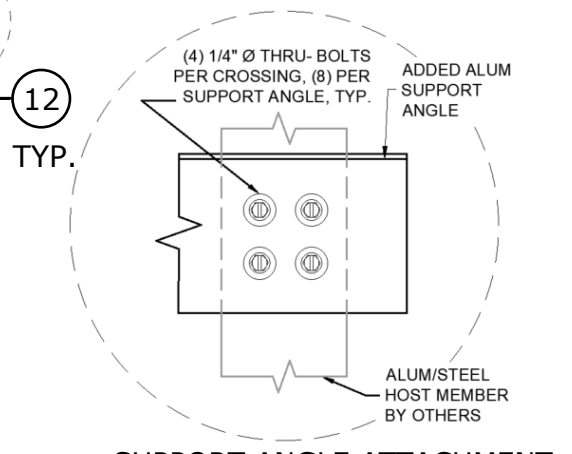

12 SUPPORT ANGLE ATTACHMENT TO ALUM/STEEL HOST, TYP.
SCALE: NTS TOP VIEW, UNIT ⊥ TO HOST

TIE-DOWN DETAILS, 9 - 12 NOTES

For each Detail in this section, consult Tie-Down Schedule and Notes herein for all tie-down components & specifications required. The units depicted in the Details on this page are for illustrative purposes only. Units may vary in appearance. Tie-down system may not be depicted in full. The sample tie-down layouts shown herein are for illustrative purposes only. Tie-down locations may vary per the specifications of the Tie-Down Schedule and Notes herein. Host structure shape may vary. For Details 9-12, the unit may be oriented either parallel, "||", or perpendicular, "⊥", to the host member direction. Details 9 and 11 show scenarios in which support angles are required to accommodate all required tie-down components; this occurs more frequently when the unit's long side is oriented perpendicularly to the host structure members as shown in Detail 11. Support angles may be omitted if tie-down components may be positioned along the host structure members only (typically only possible when unit is oriented parallel to host members and for scenarios in which fewer tie-down components are required). Fewer tie-down components may be required than shown above; see Tie-Down Schedule.

PANEL INTEGRITY SUMMARY: NOTES

The following notes apply to all Cabinet Groups described herein:

Panel integrity calculations were based on information provided by the client and manufacturer-listed specifications. Calculations are valid for all Cabinet Group unit models listed and defined herein. Specifications herein apply to the respective Cabinet Group unit models. See "Model Information" section on page 2 for Cabinet Group designations. All exterior panels were considered in the calculations and are covered by this certification. Panels were assigned various porosities depending on the ratio of louver/aperture area to total panel area, for the purposes of calculating the acting wind force on each panel. Screw sizes, quantities on panels, and panel characteristics were considered based on client-provided information and additional conservative assumptions. Screw quantities were checked to reinforce unit panels as needed.

"Additional screws" are screws that are required to be installed **in addition to** the existing screws present as part of the original unit design(s) submitted to this office, unless noted otherwise (U.N.O.). It is the installing contractor's responsibility to ensure additional screws are installed on the unit as applicable. The purpose of additional screws is to ensure panel connection integrity, referred to herein as "panel integrity", is sufficiently validated, such that the panel in question can withstand a high-speed wind gust and not detach or otherwise become flying debris.

Additional screw(s) shall be #14 (1/4" min. Ø), SAE Gr. 2 min. or SS SMS. 1000 hours of ASTM B117 with zero red rust is required for all additional screws. Position additional screw(s) as directed by the respective "Additional Screws Directive" specifications for the panel in question. Provide 1" min. spacing between neighboring screws (existing or additional). Validate that each additional screw joins the panel in question to the other specified member (as specified in the "Additional Screws Directive" where applicable). See diamond "◇" regions in the following Panel Integrity Details for approximate screw locations.

PANEL INTEGRITY SUMMARY: CABINET GROUP I

For Cabinet Group II models, no additional screws are required for installations with site-specific wind pressures up to ± 102 psf lateral & 81 psf uplift.

For Cabinet Group II installations with site-specific wind pressures greater than ± 102 psf lateral & 81 psf uplift, follow the directives and specifications as noted in the Panel Integrity Summary Tables and Notes herein:

Cabinet Group I: Up to ± 140 psf Lateral & 111 psf Uplift Wind Pressures		
Panel Designation	Addtl. Screws Required	Additional Screws Directive
Panel A2 (RH Front Panel w/o Fan)	1	Install (1) addtl. screw at the bottom of the panel, joining the panel to the unit base.
Panel C (Right Panel)	2	Install (2) addtl. screws at top of panel to join with the roof Panel (Panel E).
<p>(3) Additional Screw Required in Total per Unit. Addtl. screws shall be #14 min. Ø, SAE Gr. 2 min. or SS SMS. See notes below for further specifications.</p>		

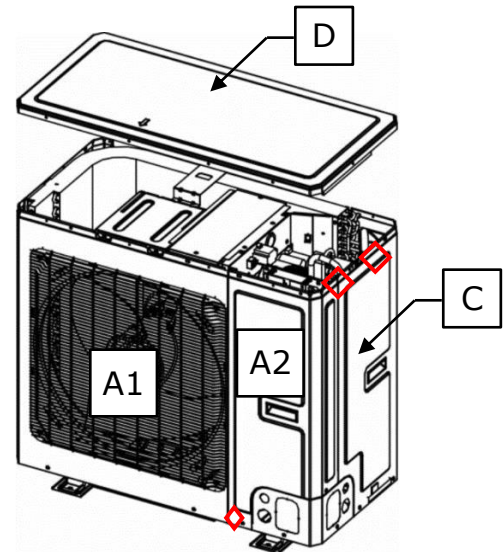

SAMPLE ADDTL. SCREW LOCATIONS
SCALE: NTS ISOMETRIC VIEW

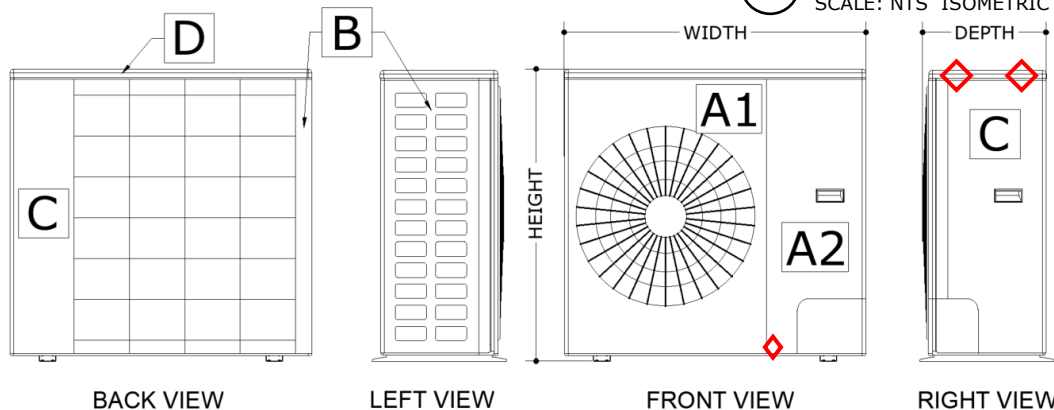

SAMPLE ADDTL. SCREW LOCATIONS
SCALE: NTS MULTIPLE VIEWS

PANEL INTEGRITY SUMMARY: CABINET GROUP II

For Cabinet Group II models, no additional screws are required for installations with site-specific wind pressures up to ± 81 psf lateral & 64 psf uplift.

For Cabinet Group II installations with site-specific wind pressures greater than ± 81 psf lateral & 64 psf uplift, follow the directives and specifications as noted in the Panel Integrity Summary Tables and Notes herein:

Cabinet Group II: Up to ± 140 psf Lateral & 111 psf Uplift Wind Pressures		
Panel Designation	Addtl. Screws Required	Additional Screws Directive
Panel A2 (RH Front Panel w/o Fans)	3	Install (1) addtl. screw at top of panel to join with roof panel (Panel E). Install (2) addtl. screws at the bottom of the panel, joining the panel to the unit base.
Panel C (Right Panel)	1	Install (1) addtl. screw at top of the panel at the back side of the unit to join with the roof panel (Panel E).
<p>(4) Additional Screw Required in Total per Unit. Addtl. screws shall be #14 min. Ø, SAE Gr. 2 min. or SS SMS. See notes below for further specifications.</p>		

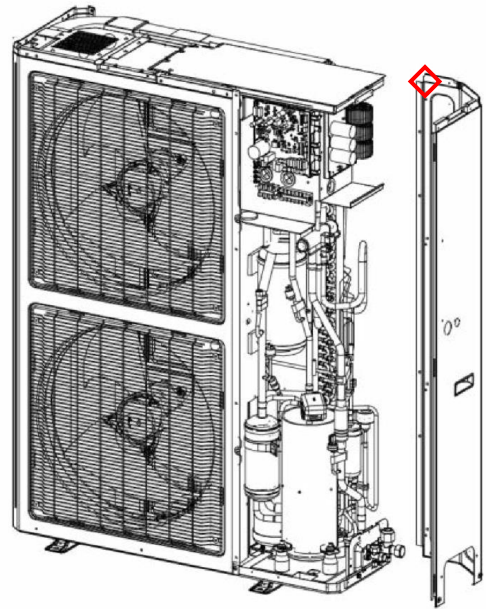

15 PANEL C ADDTL. SCREW CATIONS
SCALE: NT MULTIPLE VIEWS

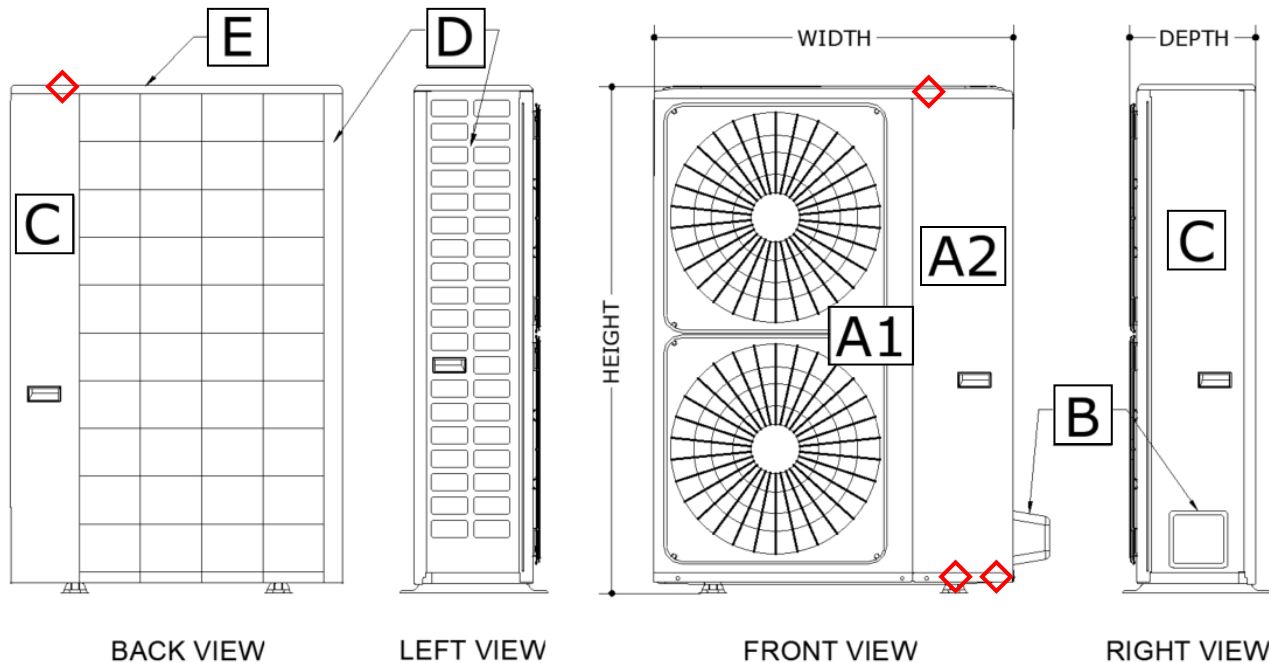

16 SAMPLE ADDTL. SCREW LOCATIONS
SCALE: NTS MULTIPLE VIEWS

TERMINOLOGY, CONTINUED

The following abbreviations may appear in this report: "Addtl." for "additional", "AHJ" for "Authority Having Jurisdiction", "alum" for "aluminum", "ASCE" for "American Society of Civil Engineers", "ASD" for "Allowable Stress Design", "ASTM" for "American Society for Testing and Materials", "EA." for "each", "E.D." for "edge distance", "EDDS" for "extra deep drawing steel", "e.g." for "exempli gratia" or "for example", "equiv." for "equivalent", "FBC" for "Florida Building Code", "FEA" for "Finite Element Analysis", "FLCA" for "Florida Certificate of Authorization", "FS" for "Florida Statutes", "Fu" for "ultimate tensile strength" or "ultimate tensile stress", "Fy" for "yield strength" or "yield stress" "GA" for "gauge", "GR." or "Gr." for "grade", "HVAC" for "heating, ventilation, and air conditioning", "HVHZ" for "High-Velocity Hurricane Zone", "i.e." for "id est" or "in other words", "in" for "inch", "lb" for "pound (force)", "max." for "maximum", "min." for "minimum", "mm" for "millimeter", "NTS" for "not to scale", "O.C." for "on center", "OD" for "outer diameter", "pcf" for "pounds (force) per cubic foot", "PE" for "Professional Engineer", "qty" for "quantity", "SAE" for "Society of Automotive Engineering", "SMS" for "sheet metal screws", "SS" for "stainless steel", "TER" for "Technical Evaluation Report", "typ." for "typical", "ult" for "ultimate loads", "U.N.O." for "unless noted otherwise", "UTS" for "ultimate tensile strength" or "ultimate tensile stress", "WLL" for "working load limit", "w/o" for "without", "YS" for "yield strength" or "yield stress", "#" for "number", "&" for "and", and "Ø" for "diameter". Please visit ecalc.io/glossary for additional abbreviation clarifications.

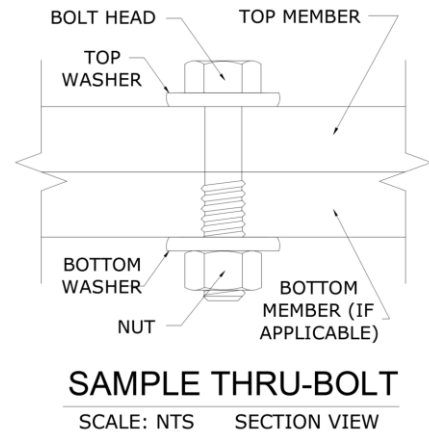

Note: The term "Thru-Bolt" or through bolt, if used herein, refers to a bolt passing through the member(s) in contact and is fastened by a nut at the end opposite the screw head. Nut shall be equivalent to or exceed the strength of the bolt U.N.O. Nut shall be sized to accommodate the same nominal diameter as the bolt U.N.O. See diagram above-right for a sample thru-bolt configuration.

Note: For instances herein which list material specifications as "[material type] or stronger": U.N.O. herein, the term "stronger" refers to a material with a UTS value equal to or greater than the UTS value of the stated material type. Consult appropriate literature for established material UTS values.

Note: Equivalent steel gauge thicknesses as used in this evaluation, U.N.O., are as follows: 22 GA (.030"), 20 GA (.036"), 18 GA (.048"), 16 GA (.060"), 14 GA (.075"), 12 GA (.098").

LIMITATIONS & CONDITIONS OF USE, CONTINUED

Use of this product shall be in strict accordance with this product evaluation as noted herein. The supporting host structure shall be designed to resist all superimposed loads as determined by others on a site-specific basis as may be required by the authority having jurisdiction. Host structure conditions which are not accounted for in this product's respective anchor schedule shall be designed for on a site-specific basis by a registered Professional Engineer. No evaluation is offered for the host supporting structure by use of this document. Adjustment factors noted herein and the applicable building codes must be considered, where applicable. Product components shall be of the material(s) specified in the manufacturer-provided product specifications. All supporting components which are permanently installed shall be protected against corrosion, contamination, and other such damage at all times. All fasteners and anchors shall be installed in accordance with the applicable provisions specified herein in addition to the anchor/fastener manufacturers' published installation instructions. Fasteners must penetrate the supporting members such that the full length of the threaded portion is embedded within the main member. This evaluation does not offer any evaluation to meet large missile impact debris requirements under any circumstances.

All of the wind-resisting exterior panels (with accompanying retrofits) individually meet or exceed their capacity to resist the design wind loads as stated in the calculations as required by the codes and standards stated herein. Due to the indeterminate nature of these units, distortion, deflection, and material deformation cannot be accurately evaluated, but with the diaphragm action of external components and internal stiffeners, the base unit (with accompanying retrofits stated herein as applicable) has the capacity to withstand the design wind loads without detaching from the unit and becoming flying debris.

Survivability: This performance evaluation is valid for a newly installed unit and do not include certification of the product beyond a design event or if impacted by any debris. Inspections shall be implemented annually by the end user and after every named storm. All fasteners and cabinet components are to be verified, and all damaged, loose, corroded and/or broken fasteners and cabinet components shall be replaced to ensure structural integrity against hurricane wind forces. Contact this office for any reevaluation needs or as designated by the Authority Having Jurisdiction.

Durability: Components or component assemblies shall not deteriorate, crack, fail, or lose functionality due to galvanic corrosion or weathering. All supporting components which are permanently installed shall be protected against corrosion, contamination, and other such damage at all times. Each component or component assembly shall be supported and oriented in its intended installation position. All exposed plastic components shall be certified to resist sunlight exposure as specified by ASTM B117, or ASTM G155 in Broward or Miami Dade counties.

Extent of Certification: Certification pertains to the overall structural integrity of the unit components listed within the evaluation as required by code, subject to the limitations and criteria stated herein. Operability during or after a design event is not included in this certification. Water infiltration is outside the bounds of this certification. No other certifications are intended other than as described herein. This evaluation alone does not offer any evaluation for large missile impact debris or cyclic wind requirements unless specifically stated herein.

Proj. #	Remarks	By	Checked	Date	Proj. #	Remarks	By	Checked	Date
23-62345	TER Version (2023 FBC Updt)	MRT	RWN	01/04/24					
24-74123	FSA Initial Issue	MRT	EPR/RWN	06/24/24					

APPENDIX A: DESIGN WIND PRESSURE GUIDE

Max. Ult. Wind Speed (V _{ult})	Max. MRH (Roof Height)	Exposure Category	Required Design Wind Pressures (ASD)	
			Lateral Pressure	Uplift Pressure
140 mph	At-Grade (0 ft)	C	± 26 psf	0* psf
		D	± 31 psf	0* psf
	100 ft	C	± 63 psf	50 psf
		D	± 71 psf	56 psf
	200 ft	C	± 72 psf	57 psf
		D	± 80 psf	63 psf
175 mph	At-Grade (0 ft)	C	± 40 psf	0* psf
		D	± 49 psf	0* psf
	100 ft	C	± 98 psf	77 psf
		D	± 111 psf	87 psf
	200 ft	C	± 113 psf	89 psf
		D	± 124 psf	98 psf
186 mph	At-Grade (0 ft)	C	± 46 psf	0* psf
		D	± 54 psf	0* psf
	100 ft	C	± 111 psf	87 psf
		D	± 125 psf	99 psf
	200 ft	C	± 127 psf	100 psf
		D	± 140 psf	111 psf

±00-psf Note: Any table values with the format shown left, if present, indicate design wind pressures and site conditions that are **not approved for use** by this evaluation. Seek additional engineering or contact this firm for design solutions.

DIRECTIVE: This design pressure guide is for reference only and shall be approved for use by the Authority Having Jurisdiction (AHJ). If the design pressures listed in this guide are not used, required design pressures shall be calculated separately. For site-specific scenarios classified as Exposure Category B, the required design pressures stated for Exposure Category C in the above guide shall be used or design pressures shall be calculated separately. For heights and parameters beyond the parameters listed in this guide, visit our Online Calculator via the website link (<https://ecalcalc.io/forces>) or QR Code below, or obtain calculations separately by others.

The required ASD design pressures listed in this guide were calculated per the table's listed corresponding site conditions. The project design professional or permitting contractor shall verify that the site-specific conditions are equal to or less than the approved design parameters listed in the guide. Per the note below table: any values shown as "XX-psf", indicate wind pressures and corresponding site conditions that are **not valid for use** with this evaluation (exceeds the max. rated pressures).

*Note: Per the codes and standards referenced herein, uplift is not required for mechanical equipment at-grade. If uplift at-grade is required by the AHJ, contact this firm for a site-specific evaluation.

At-Grade (0 ft MRH) Required Design Pressures:

- o ASCE 7 "Design Wind Loads: Other Structures"
- o Structure Shape = Square, flat terrain
- o Height of structure (unit + stand or curb, if used) = 6 ft max.
- o Width of unit = 1 ft min., Depth of unit = 11 in min.

Rooftop (>15 ft MRH) Required Design Pressures:

- o ASCE 7 "Design Wind Loads: Other Structures: Rooftop Structures and Equipment for Buildings"
- o Structure Shape = Square, flat terrain
- o z = up to 7 ft, where z = height of stand or curb + ½ unit height
- o Lateral GC_r = 1.90; Uplift GC_r = 1.50

VISIT [ECALC.IO/FORCES](https://ecalcalc.io/forces)

FOR DESIGN AID CALCULATORS AND RESOURCES RELATED TO THIS EVALUATION & GUIDES HEREIN, OR SCAN THE QR CODE RIGHT >



UNIT REACTIONS FROM WIND GUIDE

DIRECTIVE: This guide is intended for use by a design professional. Design parameters shall abide all specifications and limitations stated in this evaluation. Design professional shall consider all forces, including seismic and snow loads, per the governing building code. Unit reactions obtained from this guide shall be verified by a registered Professional Engineer. Reactions are applicable for unit-to-host connections only. Sample calculations are provided below.

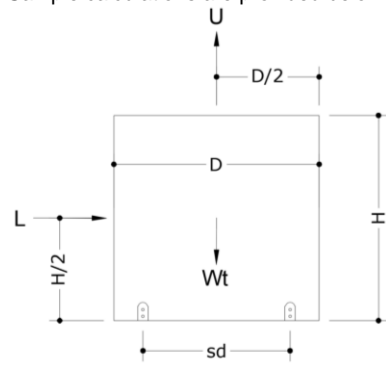

Design Parameters:

- Lateral Wind Pressure, P_{lat}
- Unit Height, H
- Unit Width, W
- Support Spacing across Depth, sd
- Uplift Wind Pressure, P_{up}
- Unit Depth, D
- Unit Weight, Wt
- Support Spacing across Width, sw

Unit Reaction Equations:

Long Side (Width x Height):

- Sliding Force, L = P_{lat} x W x H
- Uplift Force, U = P_{up} x W x D
- Total Tension per Long Side = (L x H/2 + U x sd/2 - Wt x 0.6 x sd/2) / sd

Short Side (Depth x Height):

- Sliding Force, L = P_{lat} x D x H
- Uplift Force, U = P_{up} x W x D
- Total Tension per Short Side = (L x H/2 + U x sw/2 - Wt x 0.6 x sw/2) / sw

Example: A (48" W x 36" D x 42" H), 250 lb net weight unit at wind pressures of 120 psf lateral and 95 psf uplift, on a 24" wide roof stand, shall have the following unit reactions:

Long Side (Width x Height):

- Sliding Force, L = P_{lat} x W x H = (120 psf) x (48 in) x (42 in) x (1 in² / 144 ft²) = **1680 lb**
- Uplift Force, U = P_{up} x W x D = (95 psf) x (48 in) x (36 in) x (1 in² / 144 ft²) = **1140 lb**
- Total Tension per Long Side = (L x H/2 + U x sd/2 - Wt x 0.6 x sd/2) / sd = ((1680 lb x 42/2 in) + (1140 lb x 24/2 in) - (250 lb x 0.6 x 24/2 in)) / 24 in = **1965 lb**

Short Side (Depth x Height):

- Sliding Force, L = P_{lat} x D x H = (120 psf) x (36 in) x (42 in) x (1 in² / 144 ft²) = **1260 lb**
- Uplift Force, U = P_{up} x W x D = (95 psf) x (48 in) x (36 in) x (1 in² / 144 ft²) = **1140 lb**
- Total Tension per Short Side = (L x H/2 + U x sw/2 - Wt x 0.6 x sw/2) / sw = ((1260 lb x 42/2 in) + (1140 lb x 48/2 in) - (250 lb x 0.6 x 48/2 in)) / 48 in = **1046 lb**

IN ALL CONDITIONS IT IS THE RESPONSIBILITY OF THE PERMIT HOLDER TO ENSURE THE HOST STRUCTURE IS CAPABLE OF WITHSTANDING THE RATED GRAVITY, LATERAL, AND UPLIFT FORCES BY SITE-SPECIFIC DESIGN. NO WARRANTY OF ANY KIND, EXPRESSED OR IMPLIED, IS OFFERED BY ENGINEERING EXPRESS AS TO THE INTEGRITY OF THE HOST STRUCTURE TO CARRY DESIGN FORCE LOADS INCURRED BY THIS UNIT.