



STANDARD CONSTRUCTION

FRAME/FLANGE:

28 GAUGE HOT-DIPPED GALVANIZED STEEL

MAIN BODY:

R6 FIBERGLASS DUCTBOARD

OPTIONS:

WITHOUT FLANGE (R6FGRABU)

CUSTOM SIZES AVAILABLE UPON REQUEST.

OTHER R-VALUES AVAILABLE.

FEATURES:

1" PERIMETER FLANGE PROVIDED FOR EASY INSTALLATION.

DESIGN INCLUDES 1/2" DRYWALL LIP AND ROUNDED CORNERS FOR ADDED SAFETY.

OPENING 1/2" OVERSIZED TO ACCOMMODATE RETURN-AIR GRILLE.

FIBERGLASS DUCTBOARD COATED WITH EPA REGISTERED ANTI-MICROBIAL PROTECTIVE ACRYLIC AGENT ON THE AIR STREAM SIDE.

STANDARD SIZES:

PART NUMBER	W X H X D	QTY.
R6FGRAB202008T	20" X 20" X 8"	1
R6FGRAB241808T	24" X 18" X 8"	1
R6FGRAB242408T	24" X 24" X 8"	1
R6FGRAB301808T	30" X 18" X 8"	1

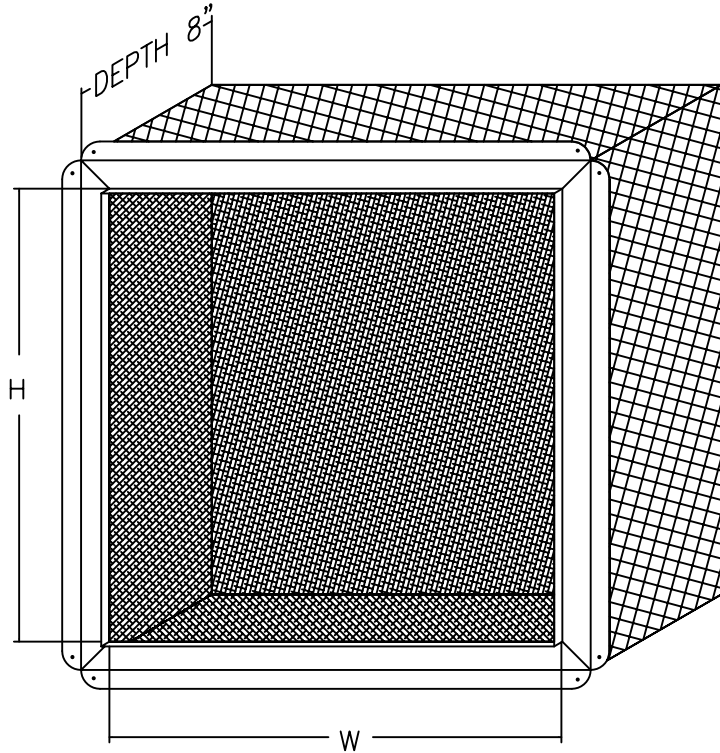

JOB NAME:
LOCATION:
ARCHITECT:
ENGINEER:
CONTRACTOR:
CONTACT MIAMI TECH INC. FOR ADDITIONAL INFORMATION OR WITH SPECIAL REQUIREMENTS.
3611 NW 74TH ST MIAMI, FL 33147 PHONE: 305-693-7054 FAX: 305-693-6152
WEB: WWW.MIAMITECH.COM EMAIL: SALES@MIAMITECH.COM

**R6FGRAB ( 8" TALL )**

R6 FIBERGLASS RETURN-AIR BOX W/FLANGE  
**PRODUCT SPECIFICATIONS**

NOTE: ALL DRAWINGS SUBJECT TO CHANGE WITHOUT PRIOR NOTICE.



DRAWN BY: EM	DATE: 06.19.2009	SCALE: NOT TO SCALE	DRAWING NO. R6FGRAB-8
CHECKED BY: IV	DATE: 09-12-11	REVISION: 3	