



STANDARD CONSTRUCTION

FRAME/FLANGE:
28 GAUGE HOT -DIPPED GALVANIZED STEEL

INSULATION:
R4.2,R6 OR R8 FIBER GLASS DUCT BOARD

OPTIONS:
W/FLANGE (R4/R6/R8FGB)

CUSTOM SIZES AVAILABLE

STANDARD SIZES :

W X H
8"X 4"
8"X 6"
8"X 8"
10"X 6"
10"X 8"
10"X 10"
12"X 6"
12"X 8"
12"X 10"
12"X 12"
12"X 6"
12"X 8"
12"X 10"
12"X 12"
14"X 6"
14"X 8"
14"X 10"
14"X 12"
14"X 14"
16"X 6"
16"X 8"
18"X 10"

FEATURES

DESIGN INCLUDES 1/2" DRYWALL LIP AND ROUNDED CORNERS FOR ADDED SAFETY

OPENING 1/4" OVERSIZED TO ACCOMMODATE REGISTER /GRILLE.

DUAL BEAD BOX DESIGN FOR ADDED STRENGTH.

FIBER GLASS DUCT BOARD COATED WITH EPA-REGISTERED,ANTI-MICROBIAL,PROTECTIVE ACRYLIC AGENT ALONG AIR STREAM SIDE.

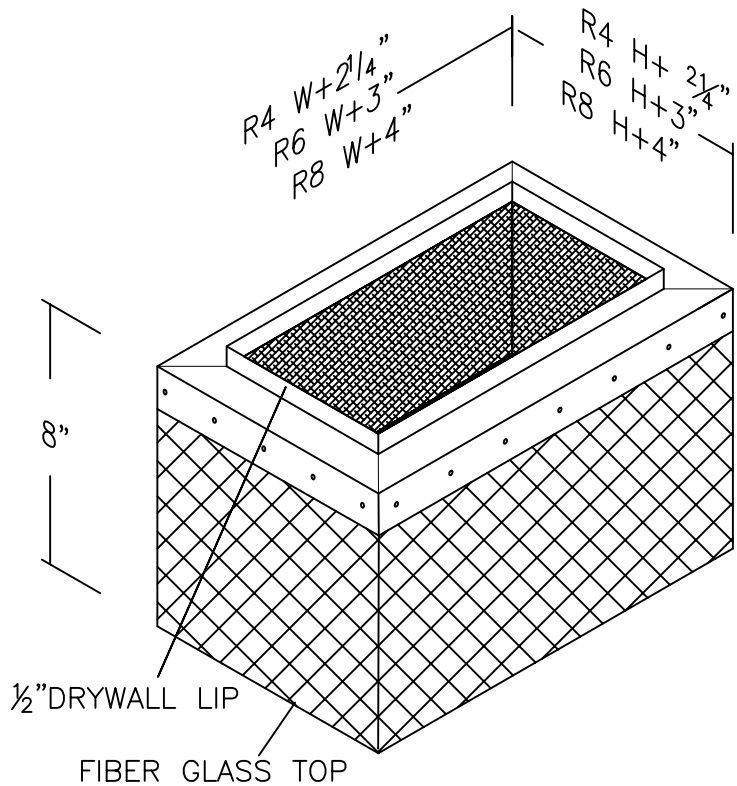

JOB NAME:
LOCATION:
ARCHITECT:
ENGINEER:
CONTRACTOR:
CONTACT MIAMI TECH INC. FOR ADDITIONAL INFORMATION OR WITH SPECIAL REQUIREMENTS. 3611 NW 74TH ST MIAMI, FL 33147 PHONE: 305-693-7054 FAX: 305-693-6152 WEB: WWW.MIAMITECH.COM EMAIL: SALES@MIAMITECH.COM

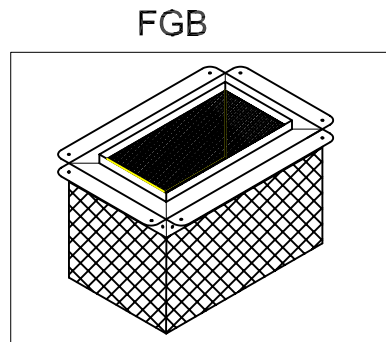

R4/R6/R8FGBU

FIBERGLASS BOOT UNFLANGED
PRODUCT SPECIFICATIONS

NOTE: ALL DRAWINGS SUBJECT TO CHANGE WITHOUT PRIOR NOTICE.



DRAWN BY: AF	DATE: 02/12/2009	SCALE: NOT TO SCALE	DRAWING NO.
CHECKED BY: IV	DATE: 02/12/2009	REVISION: 01	R4R6R8FGBU