

**STANDARD CONSTRUCTION**

FRAME/FLANGE:  
28 GAUGE HOT-DIPPED GALVANIZED STEEL

INSULATION:  
R4, R6 OR R8 FIBER GLASS DUCT BOARD

OPTIONS:  
UNFLANGED (R4/R6/R8FGU)

CUSTOM SIZES AVAILABLE

**FEATURES**

1" PERIMETER FLANGE PROVIDED FOR EASY INSTALLATION

DESIGN INCLUDES 1/2" DRYWALL LIP AND ROUNDED CORNERS FOR ADDED SAFETY

OPENING 1/4" OVERSIZED TO ACCOMMODATE REGISTER /GRILLE.

DUAL BEAD BOX DESIGN FOR ADDED STRENGTH.

FIBER GLASS DUCT BOARD COATED WITH EPA-REGISTERED, ANTI-MICROBIAL, PROTECTIVE ACRYLIC AGENT ALONG AIR STREAM SIDE.

**STANDARD SIZES :**

W X H
8" X 4"
8" X 6"
8" X 8"
10" X 6"
10" X 8"
10" X 10"
12" X 6"
12" X 8"
12" X 10"
12" X 12"
12" X 6"
12" X 8"
12" X 10"
12" X 12"
14" X 6"
14" X 8"
14" X 10"
14" X 12"
14" X 14"
16" X 6"
16" X 8"
18" X 10"

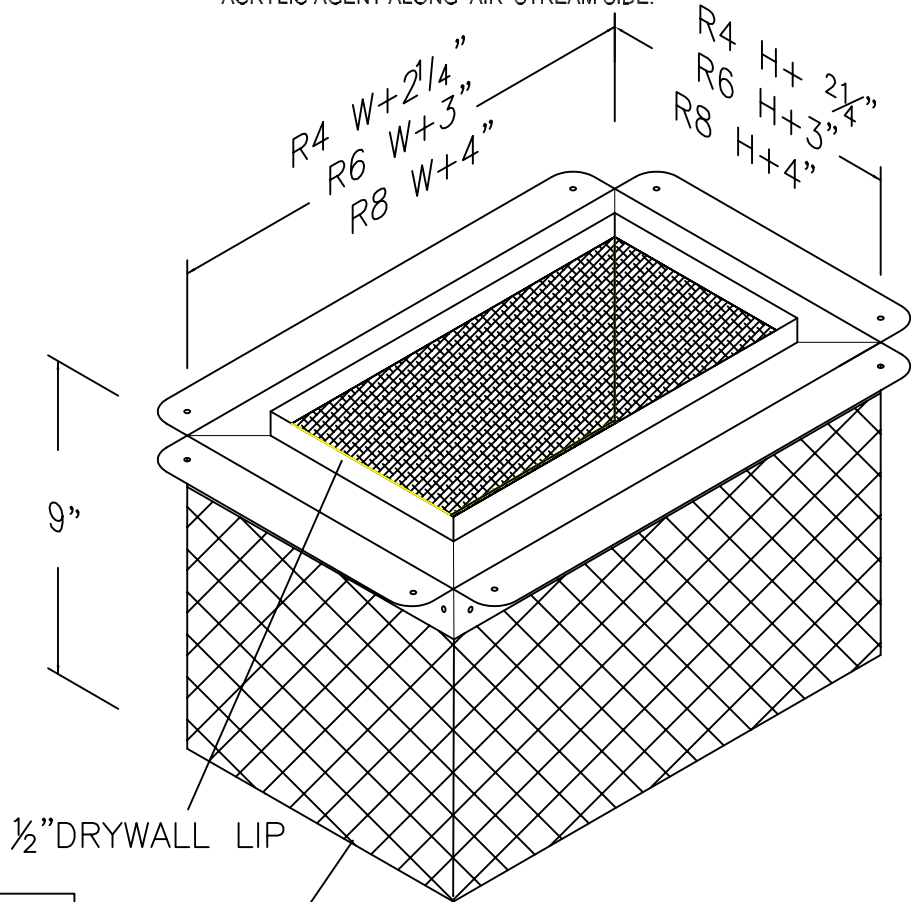

1/2" DRYWALL LIP

FIBER GLASS TOP

FGBU

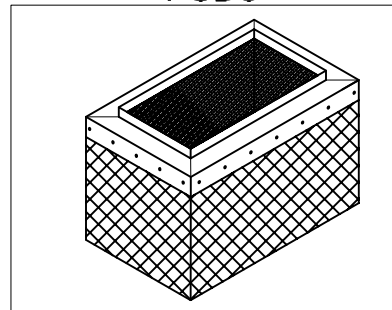

JOB NAME:
LOCATION:
ARCHITECT:
ENGINEER:
CONTRACTOR:
CONTACT MIAMI TECH INC. FOR ADDITIONAL INFORMATION OR WITH SPECIAL REQUIREMENTS.
3611 NW 74TH ST MIAMI, FL 33147 PHONE: 305-693-7054 FAX: 305-693-6152
WEB: WWW.MIAMITECH.COM EMAIL: SALES@MIAMITECH.COM

R4/R6/R8FGB  
FIBERGLASS BOOT WITH FLANGE  
PRODUCT SPECIFICATIONS

DRAWN BY: AF	DATE: 02/03/2009	SCALE: NOT TO SCALE	DRAWING NO: R4R6R8FGB
CHECKED BY: AV	DATE: 23/23/2010	REVISION: 02	