



**STANDARD CONSTRUCTION**

BODY:  
28/30 GAUGE ASTM A-653 HOT-DIPPED GALVANIZED STEEL

STANDARD SIZES:

MODEL	DIAMETER (D)	GAUGE	CASE QUANTITY
FCLN04	4"	30ga	40
FCLN05	5"	30ga	36
FCLN06	6"	30ga	36
FCLN07	7"	30ga	28
FCLN08	8"	30ga	22
FCLN09	9"	28ga	20
FCLN10	10"	28ga	16
FCLN12	12"	28ga	24
FCLN14	14"	28ga	20
FCLN16	16"	28ga	16
FCLN18	18"	28ga	14
FCLN20	20"	28ga	12

**FEATURES**

DESIGNED TO ACCOMMODATE R4 AND R6 DUCT BOARD.

3/4" FLANGE DIMENSION (EXCEEDS FLORIDA BUILDING CODE).

AVAILABLE WITH 2" STAND-OFF OR GASKET.

NESTED UNITS SAVE SPACE FOR INVENTORY.

COLLARS QUICKLY AND EASILY SNAP TOGETHER.

FULLY HEMMED, NO RAW EDGES.

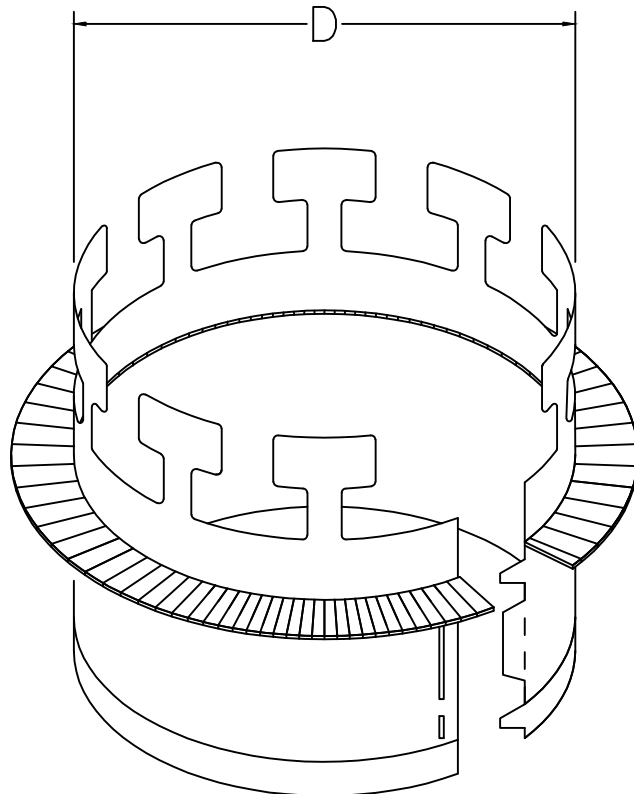

JOB NAME:
LOCATION:
ARCHITECT:
ENGINEER:
CONTRACTOR:
CONTACT MIAMI TECH INC. FOR ADDITIONAL INFORMATION OR WITH SPECIAL REQUIREMENTS. 3611 NW 74TH ST MIAMI, FL 33147 PHONE: 305-693-7054 FAX: 305-693-6152 WEB: WWW.MIAMITECH.COM EMAIL: SALES@MIAMITECH.COM

**FCLN**

NESTED TAB COLLARS FOR FIBERGLASS  
PRODUCT SPECIFICATIONS

NOTE: ALL DRAWINGS SUBJECT TO CHANGE WITHOUT PRIOR NOTICE.



DRAWN BY: CG	DATE: 08/20/07	SCALE: NOT TO SCALE	DRAWING NO. FCLN
CHECKED BY: IG	DATE: 05/18/16	REVISION: 2	