



PARTS:

1. MODEL 615: UL CLASSIFIED RADIATION DAMPER
2. REGISTER BOX BODY (30 GAUGE ASTM A-653 HOT-DIPPED GALVANIZED STEEL SHEET)
3. INSULATION: FIBERGLASS R6.0 (MODEL R6CRDS) OR R8.0 (MODEL R8CRDS) DIFFUSER BOARD
4. CONNECTION COLLAR – FIELD OR FACTORY INSTALLED (30 GAUGE ASTM A-653 HOT-DIPPED GALVANIZED STEEL SHEET)
5. REGISTER BOX FRAME (30 GAUGE ASTM A-653 HOT-DIPPED GALVANIZED STEEL SHEET)

1 HOUR RATED CRD/REGISTER/GRILLE ASSEMBLY
 CRD/REGISTER BOX ASSEMBLY FOR FLOOR/CEILING
 AND ROOF/CEILING WOOD TRUSS ASSEMBLIES OF
 CONSTRUCTION L-528, L-546, L-558, L-562, L-563,
 L-585 M-516, P-533, P-544, & P-547 TYPES.

FEATURES

- DESIGNED TO FUNCTION AS A HEAT BARRIER IN AIR OUTLETS IN FIRE RESISTANT MEMBRANE CEILINGS.
- UL APPROVED FOR USE IN DESIGN TYPES L-528, L-546, L-558, L-562, L-563, L-585, M-516, P-533, P-544, AND P-547 (SIMILAR DESIGN APPLICATIONS*: L-521, L-550, L-586 AND P-522).
- 1" PERIMETER FLANGE PROVIDED FOR BOOT CLIP OR ANGLE INSTALLATION.
- OPENING 1/4" OVERSIZED TO ACCOMMODATE REGISTER/GRILLE.
- APPROVED FOR USE WITH STEEL AND ALUMINUM GRILLES/REGISTERS.
- 6" X 4" MINIMUM / 16" X 16" MAXIMUM REGISTER DIMENSIONS.
- 4" MINIMUM / 12" MAXIMUM COLLAR DIAMETER.
- BOX DEPTH IS 11 1/2" FOR COLLARS OVER 8". ALL OTHERS ARE 9 1/4".
- DAMPER SURFACE DEPTH IS MIN 3" FROM DRYWALL LIP.
- OPTIONS: CUSTOM SIZES AVAILABLE
 PLASTER GROUND EXTENSION AVAILABLE IN 1", 1 1/2" AND 2"

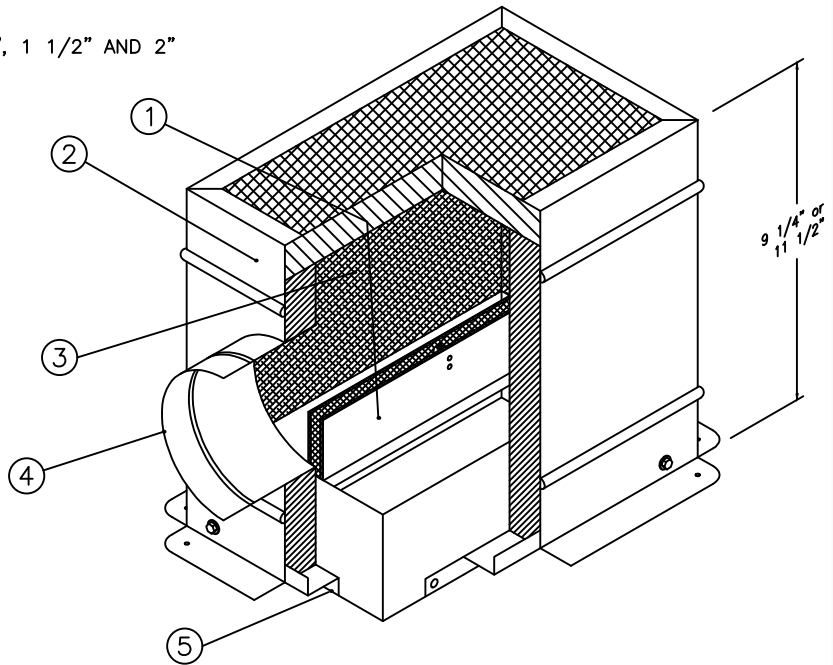

*SIMILAR DESIGN APPLICATIONS HAVE NOT BEEN EVALUATED AND ARE NOT UL CLASSIFIED FOR USE WITH THE ASSOCIATED MIAMI TECH PRODUCTS.



UNDERWRITERS LABORATORIES INC.
 555 CLASSIFIED
 PRIMARY FIRE DAMPER
 FILE NO. R10967

CRDS

CEILING RADIATION DAMPER - SIDE OUTLET SPECIFICATIONS



DRAWN BY: AV	DATE: 8/8/2013	SCALE: NOT TO SCALE	DRAWING NO.:
CHECKED BY: IG	DATE: 4/14/2016	REVISION: B	

DRAWING NO. **CRDS**