



PARTS:

1. MODEL 616: UL CLASSIFIED RADIATION DAMPER
2. CONNECTION COLLAR
(28 GAUGE ASTM A-653 HOT-DIPPED GALVANIZED STEEL SHEET)
3. METAL TOP
(26 GAUGE ASTM A-653 HOT-DIPPED GALVANIZED STEEL SHEET)
4. INSULATION: FIBERGLASS R6.0 (MODEL R6CRD) OR R8.0 (MODEL R8CRD) DIFFUSER BOARD
5. REGISTER BOX FRAME
(30 GAUGE ASTM A-653 HOT-DIPPED GALVANIZED STEEL SHEET)
6. 1" PERIMETER FLANGE
7. 1/2" DRYWALL LIP STANDARD

1 HOUR RATED CRD/REGISTER/GRILLE ASSEMBLY
CRD/REGISTER BOX ASSEMBLY FOR FLOOR/CEILING
AND ROOF/CEILING WOOD TRUSS ASSEMBLIES OF
CONSTRUCTION L-528, L-546, L-558, L-562, L-563,
L-585 M-516, P-533, P-544, & P-547 TYPES.

FEATURES

DESIGNED TO FUNCTION AS A HEAT BARRIER IN AIR HANDLER OPENINGS IN FIRE RESISTANT MEMBRANE CEILINGS.

UL APPROVED FOR USE IN DESIGN TYPES L-528, L-546, L-558, L-562, L-563, L-585, M-516, P-533, P-544, AND P-547 (SIMILAR DESIGN APPLICATIONS*: L-521, L-550, L-586 AND P-522).

1" PERIMETER FLANGE PROVIDED FOR BOOT CLIP OR ANGLE INSTALLATION.

OPENING 1/4" OVERSIZED TO ACCOMMODATE REGISTER/GRILLE.

APPROVED FOR USE WITH STEEL AND ALUMINUM GRILLES/REGISTERS.

6" X 4" MINIMUM / 16" X 16" MAXIMUM REGISTER DIMENSIONS.

4" MINIMUM / 12" MAXIMUM COLLAR DIAMETER.

OPTIONS: CUSTOM SIZES AVAILABLE
PLASTER GROUND EXTENSION AVAILABLE IN 1", 1 1/2" AND 2"

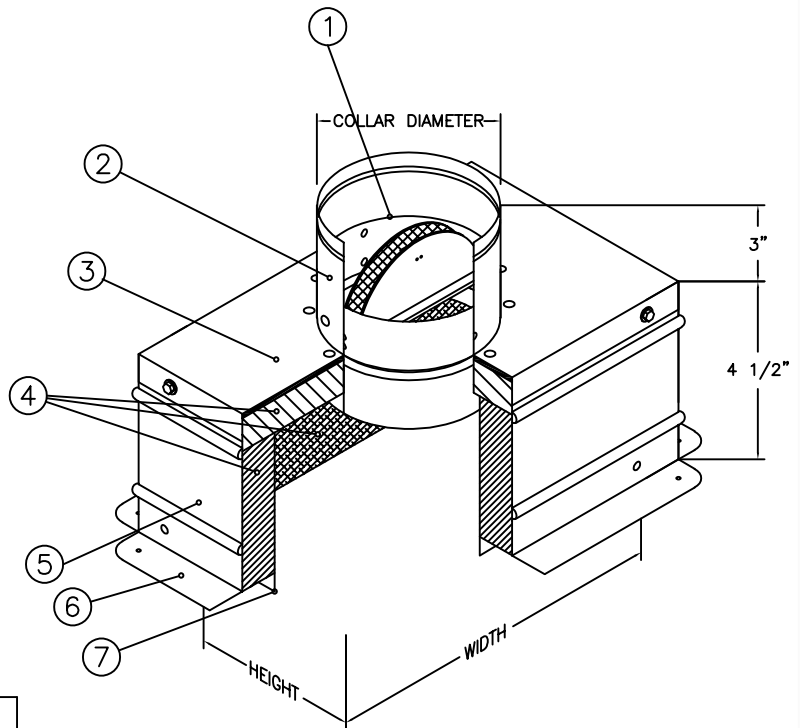
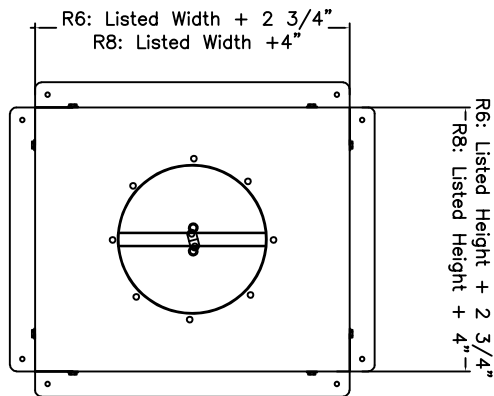

*SIMILAR DESIGN APPLICATIONS HAVE NOT BEEN EVALUATED AND ARE NOT UL CLASSIFIED FOR USE WITH THE ASSOCIATED MIAMI TECH PRODUCTS.



UNDERWRITERS LABORATORIES INC.
555C CLASSIFIED
PRIMARY FIRE DAMPER
FILE NO. R10967

CRD
CEILING RADIATION DAMPER
SPECIFICATIONS



DRAWN BY: AV	DATE: 6/20/05	SCALE: NOT TO SCALE	DRAWING NO. CRD
CHECKED BY: IG	DATE: 04/14/16	REVISION: E	