

MIAMI TECH, INC. ALUMINUM WALL BRACKET SUPPORTS

NOTE:
WALL BRACKET SUPPORTS AS ILLUSTRATED HEREIN ARE NOT INTENDED FOR ROOF-TOP MOUNTING CONDITIONS. THIS DESIGN SHALL NOT BE USED AT PARAPETS, ANY PART OF THE BUILDING THAT EXCEEDS THE FINISHED ROOF ELEVATION, OR ANY WALL ZONE WITHIN 10% OF THE SHORTEST BUILDING DIMENSION PER ASCE 7-10.

**MAXIMUM ALLOWABLE
DESIGN PRESSURES:**

+/- 90 PSF

DESIGN NOTES:

DESIGN PRESSURES CALCULATED FOR USE WITH THIS SYSTEM SHALL BE DETERMINED SEPARATELY ON A JOB-SPECIFIC BASIS IN ACCORDANCE WITH THE GOVERNING CODE USING ASD METHODOLOGY. SITE-SPECIFIC PRESSURE REQUIREMENTS AS DETERMINED IN ACCORDANCE WITH ASCE 7-10 AND CHAPTER 16 OF FLORIDA BUILDING CODE SIXTH EDITION (2017) SHALL BE LESS THAN OR EQUAL TO THE LATERAL AND UPLIFT DESIGN PRESSURE CAPACITY VALUES LISTED HEREIN FOR ANY ASSEMBLY AS SHOWN.

GENERAL NOTES:

- THIS SPECIFICATION HAS BEEN DESIGNED AND SHALL BE FABRICATED IN ACCORDANCE WITH THE REQUIREMENTS OF THE FLORIDA BUILDING CODE SIXTH EDITION (2017) FOR USE WITHIN AND OUTSIDE THE HVHZ. DESIGN CRITERIA BEYOND AS STATED HEREIN MAY REQUIRE ADDITIONAL SITE-SPECIFIC SEALED ENGINEERING.
- THE ARCHITECT/ENGINEER OF RECORD FOR THE PROJECT SUPERSTRUCTURE WITH WHICH THIS DESIGN IS USED SHALL BE RESPONSIBLE FOR THE INTEGRITY OF ALL SUPPORTING SURFACES TO THIS DESIGN WHICH SHALL BE COORDINATED BY THE PERMITTING CONTRACTOR.
- MAXIMUM DIMENSIONS AND WEIGHT OF A/C UNIT SHALL CONFORM TO SPECIFICATIONS STATED HEREIN.
- SEPARATE 'SITE-SPECIFIC' SEALED ENGINEERING SHALL BE REQUIRED IN ORDER TO DEVIATE FROM LOADS, OR MAXIMUM MEMBER SPANS CONTAINED HEREIN.
- THE SYSTEM DETAILED HEREIN IS GENERIC AND DOES NOT PROVIDE INFORMATION FOR A SPECIFIC SITE. FOR SITE CONDITIONS DIFFERENT FROM THE CONDITIONS DETAILED HEREIN, A LICENSED ENGINEER OR REGISTERED ARCHITECT SHALL PREPARE SITE SPECIFIC DOCUMENTS FOR USE IN CONJUNCTION WITH THIS DOCUMENT.
- FASTENERS SHALL BE CADMIUM-PLATED OR OTHERWISE CORROSION-RESISTANT MATERIAL AND SHALL COMPLY WITH "SPECIFICATIONS FOR ALUMINUM STRUCTURES" & ANY APPLICABLE FEDERAL, STATE, AND/OR LOCAL CODES.
- ALL STEEL MEMBERS SHALL HAVE TENSILE STRENGTH OF 90 KSI MIN.
- ALL ALUMINUM EXTRUSIONS/ MEMBERS SHALL BE 6061-T6 OR 6005-T5 ALUMINUM ALLOY, UNLESS NOTED OTHERWISE.
- ALUMINUM WELDING SHALL BE PERFORMED IN ACCORDANCE WITH FBC SECTION 2003.8.1.4 WITH WELD FILLER ALLOYS MEETING ANSI/AWS A5.10 STANDARDS TO ACHIEVE ULTIMATE DESIGN STRENGTH IN ACCORDANCE WITH THE ALUMINUM DESIGN MANUAL, TABLE A.3.6, ALL ALUMINUM CONSTRUCTION SHALL BE IN CONFORMANCE WITH THE TOLERANCES, QUALITY AND METHODS OF CONSTRUCTION AS SET FORTH IN FBC SECTION 2003.2. MINIMUM WELD IS 3/16" THROAT FULL PERIMETER FILLET WELD UNLESS OTHERWISE NOTED.
- CONCRETE ANCHORS NOTED HEREIN SHALL BE EMBEDDED TO UN-CRACKED CONCRETE ONLY. INSTALL ALL CONCRETE ANCHORS PER MANUFACTURER'S RECOMMENDATIONS.
- THE CONTRACTOR IS RESPONSIBLE TO INSULATE ALL MEMBERS FROM DISSIMILAR MATERIALS TO PREVENT ELECTROLYSIS.
- ELECTRICAL GROUND, WHEN REQUIRED, TO BE DESIGNED & INSTALLED BY OTHERS. ALL MECHANICAL SPECIFICATIONS (CLEAR SPACE, TONNAGE, ETC) SHALL BE AS PER MANUFACTURER RECOMMENDATIONS AND ARE THE EXPRESS RESPONSIBILITY OF THE CONTRACTOR.
- ENGINEER SEAL AFFIXED HERE TO VALIDATES STRUCTURAL DESIGN AS SHOWN ONLY. USE OF THIS SPECIFICATION BY CONTRACTOR, et. al. INDEMNIFIES & SAVES HARMLESS THIS ENGINEER FOR ALL COST & DAMAGES INCLUDING LEGAL FEES & APPELLATE FEES RESULTING FROM MATERIAL FABRICATION, SYSTEM ERECTION, & CONSTRUCTION PRACTICES BEYOND THAT WHICH IS CALLED FOR BY LOCAL, STATE, & FEDERAL CODES & FROM DEVIATIONS OF THIS PLAN.
- EXCEPT AS EXPRESSLY PROVIDED HEREIN, NO ADDITIONAL CERTIFICATIONS OR AFFIRMATIONS ARE INTENDED.
- ALTERATIONS, ADDITIONS OR OTHER MARKINGS TO THIS DOCUMENT ARE NOT PERMITTED AND INVALIDATE THIS CERTIFICATION.

FRANK L. BENNARD, P.E.
PE# 0046549

02/02/2018

CHECKED, CERTIFYING P.E. APPEARS BELOW
GORDON DIBATISTO, P.E.
PE# 82322

VALID FOR 1 PERMIT ONLY U.N.O.

NOTICE: IF THIS SHEET DOES NOT CONTAIN AN ORIGINAL SIGNATURE & ENGINEER SEAL:

IF THERE IS A DIGITAL SIGNATURE ON SHEET 1, THIS SHEET IS PART OF A DIGITALLY SIGNED FILE, SHALL REMAIN IN DIGITAL FORMAT, & PRINTED COPIES OF THIS DOCUMENT ARE NOT CONSIDERED SIGNED AND SEALED. IF THERE IS NO DIGITAL SIGNATURE ON SHEET 1 OR THIS SHEET DOES NOT CONTAIN AN ENGINEER'S ORIGINAL SIGNATURE & SEAL, THIS SHEET IS A COPY/DRAFT.

ENGINEERING EXPRESS
CORPORATE OFFICE:
160 SW 12th AVE, SUITE 106
DEERFIELD BEACH, FL 33442
P: (954) 354-0660 F: (954) 354-0443
E: HELLO@ENGINEERINGEXPRESS.COM
ENGINEERINGEXPRESS.COM
CERT OF AUTH # 9885

MIAMI TECH, INC.
3611 NW 74TH ST
MIAMI, FL
(305) 693-7054
WALL BRACKET AC STAND
MASTER PLAN SHEET
FLORIDA BUILDING CODE SIXTH EDITION (2017)

DRWN	CHKD	DATE
LAO	JCF	11/08/16
LAO	FLB	02/02/18

REMARKS
INIT ISSUE
REV FOR 2017 FBC

THIS DOCUMENT IS THE PROPERTY OF ENGINEERING EXPRESS AND SHALL NOT BE REPRODUCED OR TRANSMITTED IN ANY FORM OR BY ANY MEANS, WITHOUT THE WRITTEN CONSENT OF ENGINEERING EXPRESS. ADDITIONS OR OTHER MARKINGS TO THIS DOCUMENT ARE NOT PERMITTED AND INVALIDATE OUR CERTIFICATION.

COPYRIGHT ENGINEERING EXPRESS

16-3762

SCALE: NTS UNLESS NOTED

1 OF 1

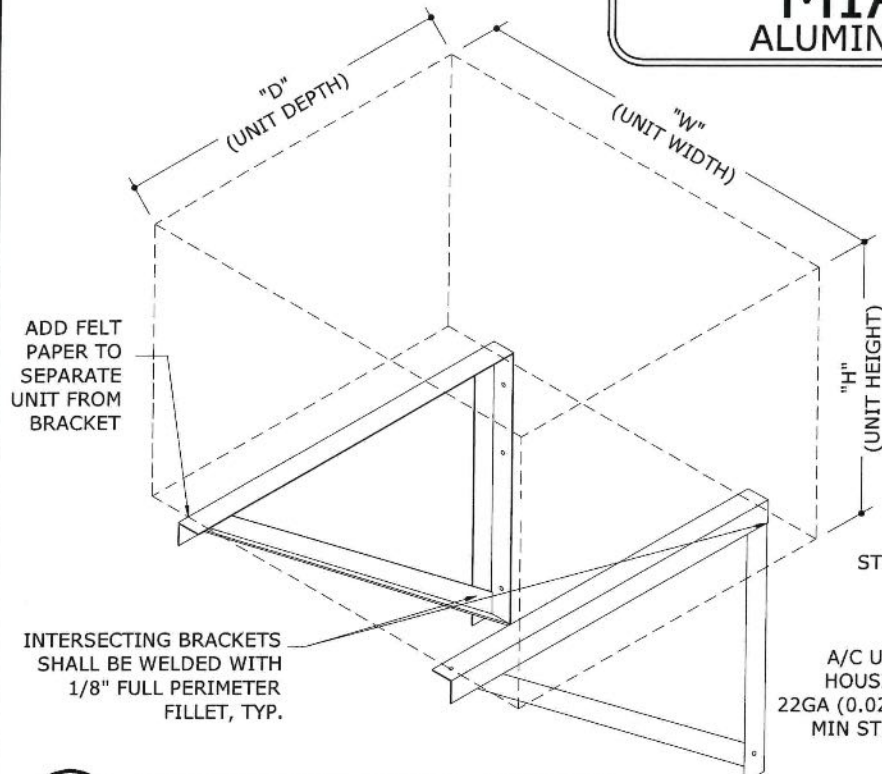

1 ALUMINUM WALL STAND
1 N.T.S. ISOMETRIC VIEW

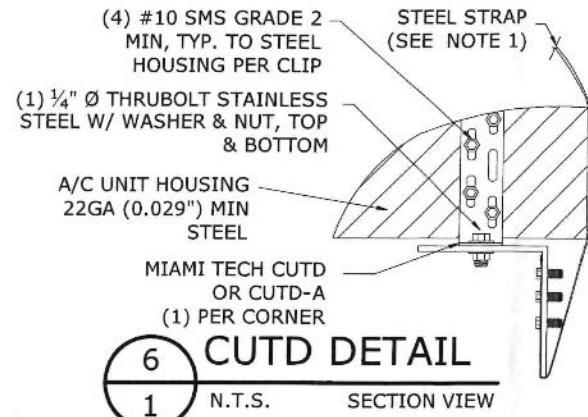

6 CUTD DETAIL
1 N.T.S. SECTION VIEW

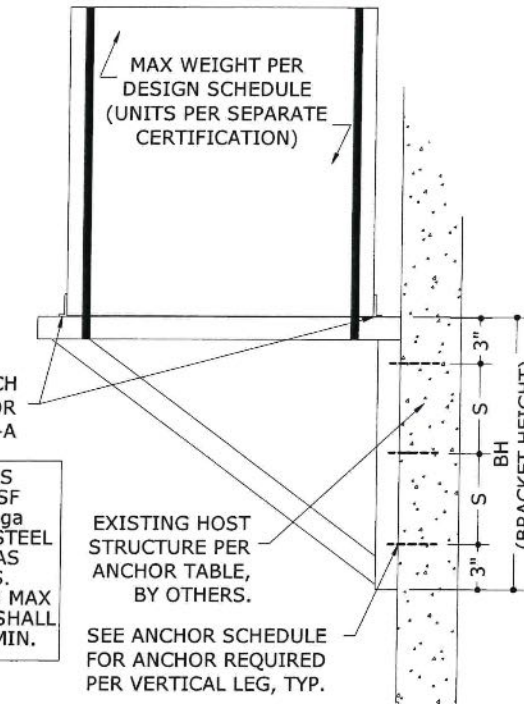

2 ALUMINUM WALL STAND
1 N.T.S. SECTION VIEW

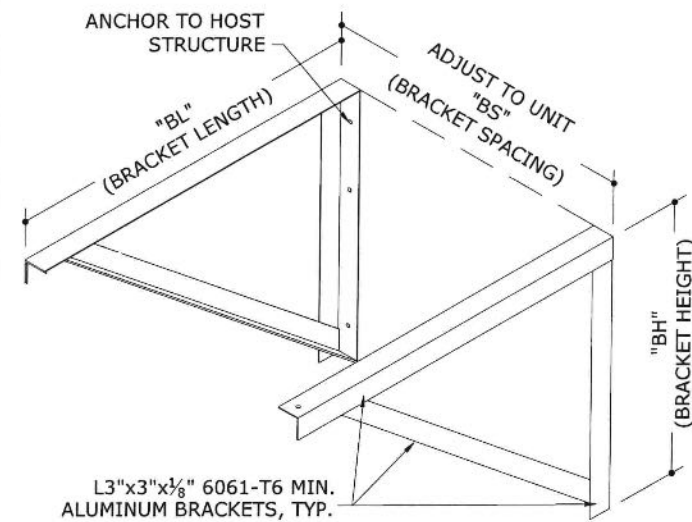

3 ALUMINUM WALL STAND
1 N.T.S. ISOMETRIC VIEW

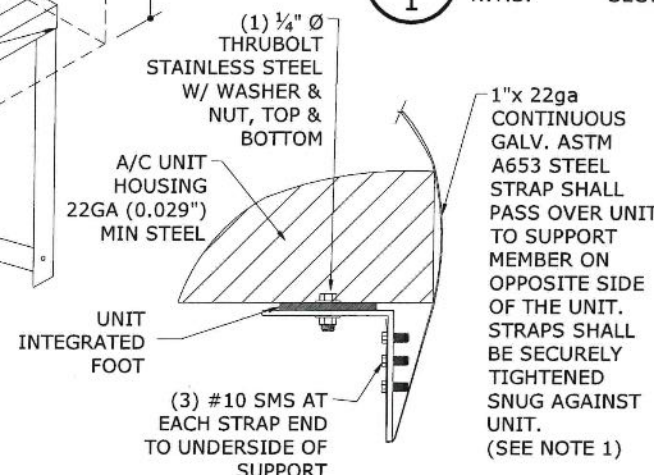

5 STRAP DETAIL
1 N.T.S. SECTION VIEW

ANCHOR SCHEDULE:

SUBSTRATE	ANCHOR
CONCRETE: (5" THICK MIN, 3000 PSI MIN.)	3/8"Ø CARBON STEEL POWERS WEDGE BOLTS WITH 3/8"Ø SAE WASHER, 2 1/2" FULL EMBED TO NON-CRACKED CONCRETE, 4" MIN. EDGE DISTANCE, SPACING AS ILLUSTRATED IN ELEVATION/SECTION.
GROUT FILLED CMU: (SHALL CONFORM TO ASTM C90)	3/8"Ø CARBON STEEL POWERS WEDGE BOLTS WITH 3/8"Ø SAE WASHER, 2 1/2" FULL EMBED TO GROUT FILLED BLOCK, 12" MIN. EDGE DISTANCE, SPACING AS ILLUSTRATED IN ELEVATION/SECTION.
WOOD: (G=0.55 MIN.)	1/2"Ø CARBON STEEL WOOD LAG SCREW W/ 1/2"Ø SAE WASHER, 2 3/8" MIN. THREAD PENETRATION TO WOOD HOST, 3/4" MIN. EDGE DISTANCE, SPACING AS ILLUSTRATED IN SECTION.
STEEL: (GR. 33, 1/2" THICK MIN.)	5/16"Ø STAINLESS STEEL SELF DRILLING SCREW W/ 1"Ø SELF LOCKING WASHER. 3/4" EDGE DISTANCE MIN., SPACING AS ILLUSTRATED IN SECTION.

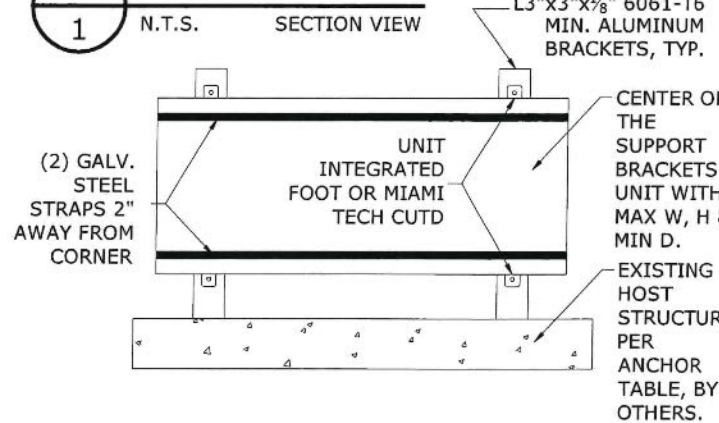

4 ALUMINUM WALL STAND
1 N.T.S. PLAN VIEW

DESIGN SCHEDULE:

CONFIGURATION TYPE	BRACKET DIMENSIONS			MAX UNIT DIMENSIONS				MIN DIM D	ANCHORS		MAXIMUM TOTAL UNIT WEIGHT
	BL	BS	BH	W	D	H	D		QTY. PER BRACKET LEG	S	
AWB2418	24"	ADJUST TO UNIT	18"	30"	20"	30"	10"	(3)	6"	350 LB	
AWB3630	36"		30"	30"	30"	35"	15"	(3)	12"	350 LB	
AWB4836	48"		36"	36"	36"	40"	28"	(3)	15"	400 LB	

- EMBEDMENT AND EDGE DISTANCE EXCLUDES FINISHES, IF APPLICABLE.
- ENSURE MINIMUM EDGE DISTANCE AS NOTED IN ANCHOR SCHEDULE.
- INSTALL ALL ANCHORS PER MANUFACTURER'S SPECIFICATIONS.
- PRE-DRILL WOOD LAGS TO AVOID SPLITTING OF WOOD MEMBERS.

02/02/2018 - 10:45am luiso V:\Projects\16-3762 Wall Bracket AC Stand MP\SWP\16-3762b Wall Bracket AC Stand.dwg