

FOR USE WITHIN AND OUTSIDE THE HIGH VELOCITY HURRICANE ZONE (HVHZ)

ALUMINUM A/C STAND WITH TELESCOPIC CROSS-MEMBER

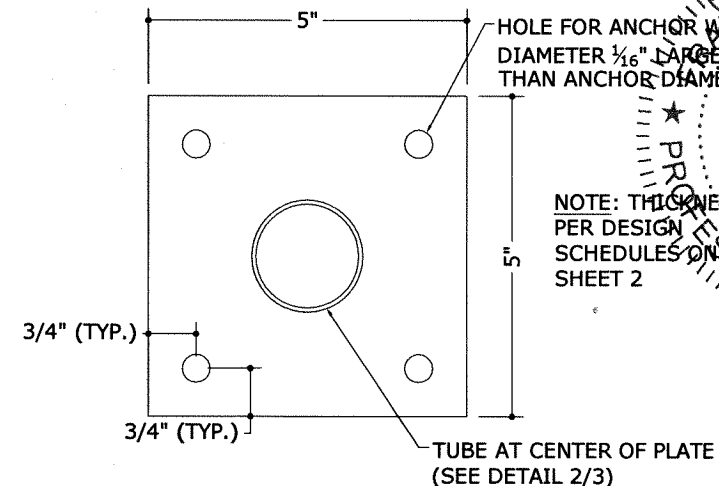
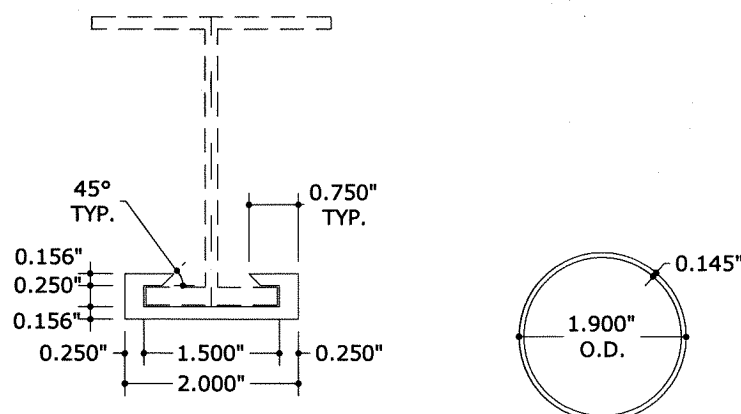
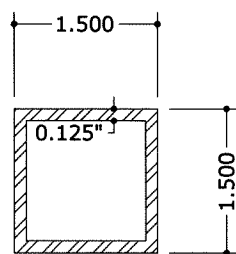
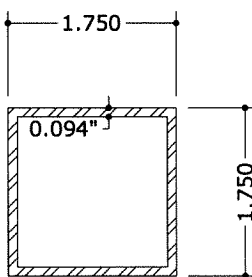
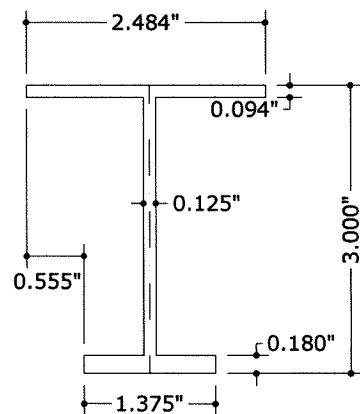

1 RAIL (I-BEAM)
6061-T6 ALUM. ALLOY

2 SQUARE TUBING
6061-T6 ALUM

2.1 SQUARE TUBING
6061-T6 ALUM

3 C-CHANNEL
6061-T6 ALUM. ALLOY

4 ROUND TUBING
6061-T6 ALUM. ALLOY

5 BASE PLATE
6061-T6 ALUM. ALLOY

GENERAL NOTES

- THIS SYSTEM HAS BEEN DESIGNED AND SHALL BE FABRICATED IN ACCORDANCE WITH THE STRUCTURAL PROVISIONS OF THE FLORIDA BUILDING CODE SIXTH EDITION (2017).
- MAXIMUM DIMENSIONS AND WEIGHT OF A/C UNIT SHALL CONFORM TO SPECIFICATIONS STATED HEREIN, MINIMUM 75LB OR MAXIMUM AS LISTED HEREIN.
- THE ARCHITECT/ENGINEER OF RECORD FOR THE PROJECT SUPERSTRUCTURE WITH WHICH THIS DESIGN IS USED SHALL BE RESPONSIBLE FOR THE INTEGRITY OF ALL SUPPORTING SURFACES TO THIS DESIGN WHICH SHALL BE COORDINATED BY THE PERMITTING CONTRACTOR.
- ALL FASTENERS TO BE #10 OR GREATER SAE GRADE 5, UNLESS NOTED OTHERWISE, CADMIUM PLATED OR OTHERWISE CORROSION RESISTANT MATERIAL AND SHALL COMPLY WITH J.3.7.2, SPECIFICATIONS FOR ALUM. STRUCTURES - SECTION 1, THE ALUMINUM ASSOCIATION, INC., & APPLICABLE FEDERAL, STATE, AND LOCAL CODES. PROVIDE (5) PITCHES MIN PAST THREAD PLANE.
- ALL EXTRUDED MEMBERS SHALL BE ALUMINUM ALLOY TYPE 6061-T6 OR 6005-T5.
- ALL EXISTING CONCRETE SUBSTRATE SHALL HAVE MINIMUM f'_c COMPRESSIVE STRENGTH OF 3000 PSI AS VERIFIED BY OTHERS.
- ALUMINUM WELDING SHALL BE PERFORMED IN ACCORDANCE WITH FBC SECTION 2003.8.1.4 WITH WELD FILLER ALLOYS MEETING ANSI/AWS A5.10 STANDARDS TO ACHIEVE ULTIMATE DESIGN STRENGTH IN ACCORDANCE WITH THE ALUMINUM DESIGN MANUAL, TABLE A.3.6. SUGGESTED WELD FILLER: 5356 ELECTRODES. ALL ALUMINUM CONSTRUCTION SHALL BE IN CONFORMANCE WITH THE TOLERANCES, QUALITY AND METHODS OF CONSTRUCTION AS SET FORTH IN FBC SECTION 2003.2 AND THE AMERICAN WELDING SOCIETY'S STRUCTURAL WELDING CODE-ALUMINUM (D1.2). MINIMUM WELD IS $\frac{1}{8}$ " THROAT FULL PERIMETER FILLET WELD UNLESS OTHERWISE NOTED.
- THE CONTRACTOR IS RESPONSIBLE TO INSULATE MEMBERS FROM DISSIMILAR MATERIALS TO PREVENT ELECTROLYSIS.
- ELECTRICAL GROUND, WHEN REQUIRED, TO BE DESIGNED & INSTALLED BY OTHERS. ALL MECHANICAL SPECIFICATIONS (CLEAR SPACE, TONNAGE, ETC.) SHALL BE AS PER MANUFACTURER RECOMMENDATIONS AND ARE THE EXPRESS RESPONSIBILITY OF THE CONTRACTOR.
- ENGINEER SEAL AFFIXED HERETO VALIDATES STRUCTURAL DESIGN AS SHOWN ONLY. USE OF THIS SPECIFICATION BY CONTRACTOR, et. al. INDEMNIFIES & SAVES HARMLESS THIS ENGINEER FOR ALL COST & DAMAGES INCLUDING LEGAL FEES & APPELLATE FEES RESULTING FROM MATERIAL FABRICATION, SYSTEM ERECTION, CONSTRUCTION PRACTICES BEYOND THAT WHICH IS CALLED FOR BY LOCAL, STATE, & FEDERAL CODES & FROM DEVIATIONS OF THIS PLAN.
- THE SYSTEM DETAILED HEREIN IS GENERIC AND DOES NOT PROVIDE INFORMATION FOR A SPECIFIC SITE. FOR SITE CONDITIONS DIFFERENT FROM THE CONDITIONS DETAILED HEREIN, A LICENSED ENGINEER OR REGISTERED ARCHITECT SHALL PREPARE SITE SPECIFIC DOCUMENTS FOR USE IN CONJUNCTION WITH THIS DOCUMENT.
- EXCEPT AS EXPRESSLY PROVIDED HEREIN, NO ADDITIONAL CERTIFICATIONS OR AFFIRMATIONS ARE INTENDED.

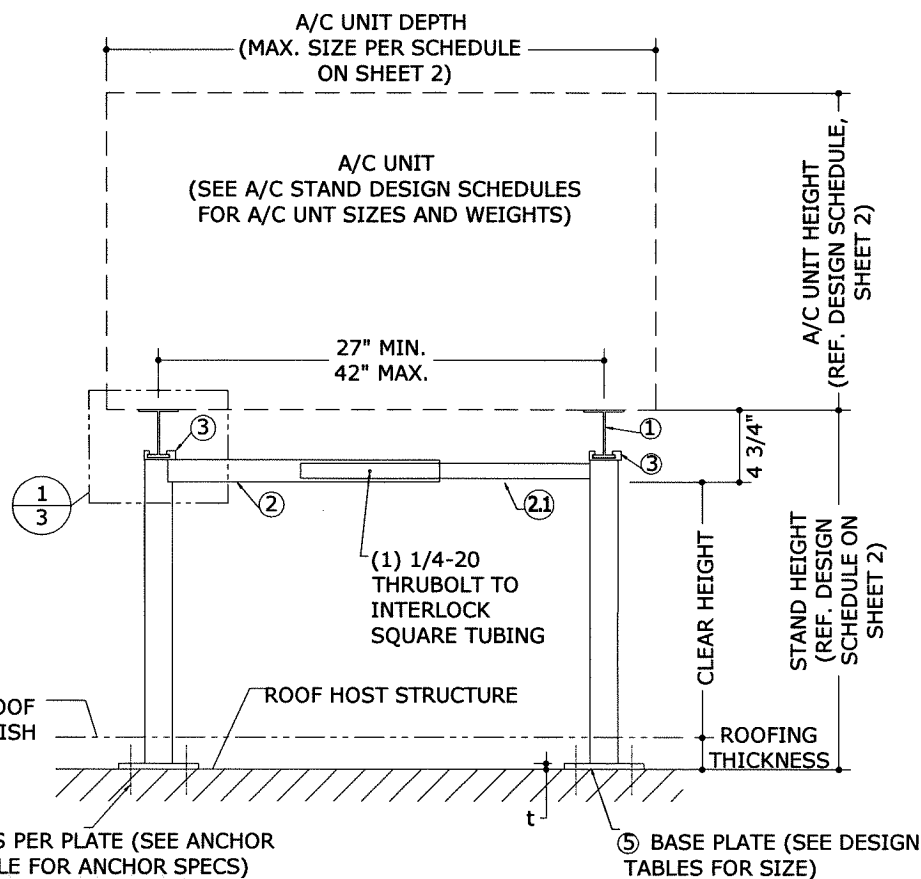
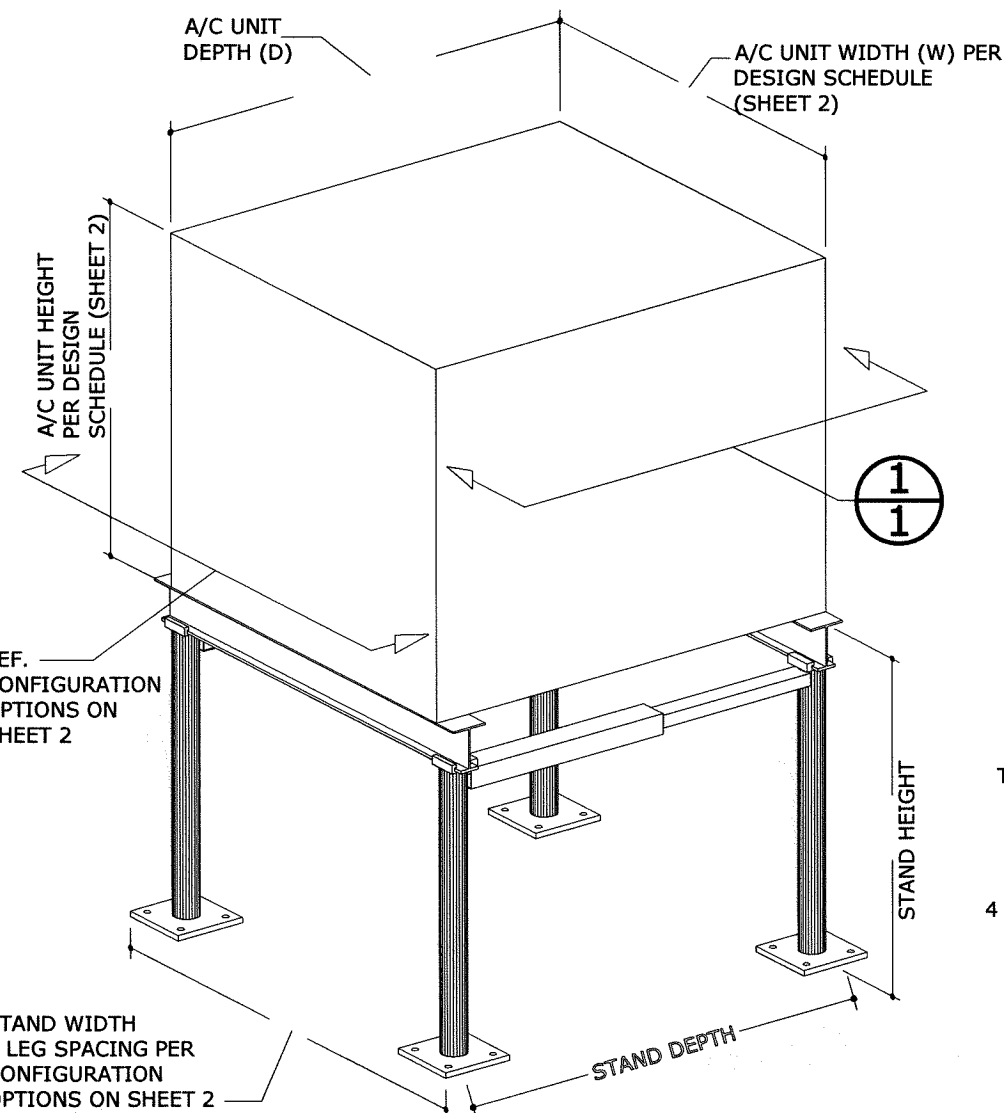

1 FRAME ASSEMBLY ELEVATION
SCALE: NTS

FRANK L. BENNARDO, P.E.
#PE0046549
10/12/2017

ENGINEERING EXPRESS
CORPORATE OFFICE:
160 SW 12th AVE., SUITE 106
DEERFIELD BEACH, FL 33442
P: (954) 354-0660 F: (954) 354-4683
E: HELLO@ENGINEERINGEXPRESS.COM
ENGINEERINGEXPRESS.COM
CERT OF AUTH #9885

MIAMI TECH, INC
3611 NW 74TH STREET
MIAMI, FL 33147
PHONE: (305) 693-7054 FAX: (305) 693-6125
ALUMINUM A/C STAND
HVHZ & NON-HVHZ
FLORIDA STATEWIDE APPROVAL FL21464.1

DRWN	CHKD	DATE
RWN	FLB	11/30/16
RWN	FLB	10/10/17

REMARKS
INIT ISSUE
REV - 2017 FBC

COPYRIGHT ENGINEERING EXPRESS

16-3757

SCALE: NTS

PAGE DESCRIPTION:

1 OF 3

V:\Projects\16-3757 Non - HVHZ Master Plan Sheet\WPV2017 FBC Update\16-3757h-Dwg-21464.1.dwg
10/12/2017 - 8:35pm zachr

HVHZ = MIAMI-DADE COUNTY AND BROWARD COUNTY

STAND AND UNIT CONFIGURATIONS WITH ASSOCIATED DESIGN SCHEDULE

FOR USE WITHIN AND OUTSIDE THE HIGH VELOCITY HURRICANE ZONE (HVHZ)

DESIGN SCHEDULE:

UNIT DIMENSIONS H x W x D	POST HEIGHT	BASE PLATE THICKNESS	ALLOWABLE LATERAL WIND PRESSURES			MAX UNIT WEIGHT	MIN UNIT WEIGHT
			STAND TYPE A	STAND TYPE B	STAND TYPE C		
27" x 24" x 24"	18.5"	1/4"	165 PSF	103 PSF	83 PSF	450 LBS	75 LBS
	24"		132 PSF	82 PSF	66 PSF	450 LBS	75 LBS
	30"		108 PSF	68 PSF	54 PSF	450 LBS	75 LBS
34" x 30" x 30"	18.5"	1/4"	101 PSF	63 PSF	51 PSF	450 LBS	75 LBS
	24"		81 PSF	51 PSF	41 PSF	450 LBS	75 LBS
	30"		67 PSF	42 PSF	33 PSF	450 LBS	75 LBS
36" x 30" x 30"	18.5"	1/4"	96 PSF	60 PSF	48 PSF	450 LBS	75 LBS
	24"		77 PSF	48 PSF	38 PSF	450 LBS	75 LBS
	30"		63 PSF	39 PSF	32 PSF	450 LBS	75 LBS
45" x 36" x 36"	18.5"	1/4"	62 PSF	39 PSF	31 PSF	450 LBS	75 LBS
	24"		50 PSF	31 PSF	25 PSF	450 LBS	75 LBS
	30"		41 PSF	26 PSF	20 PSF	450 LBS	75 LBS

DESIGN SCHEDULE NOTES:

- SITE SPECIFIC DESIGN PRESSURES SHALL BE BY OTHERS AND COMPARED TO THE LIMITING ALLOWABLE PRESSURE VALUES HEREIN. IN NO CASE ARE THE DESIGN SCHEDULE VALUES INTENDED TO CERTIFY ANY EXISTING CONDITION.
- MAXIMUM ALLOWABLE UPLIFT PRESSURE SHALL BE 79% OF THE ALLOWABLE LATERAL WIND PRESSURE.
- MAXIMUM UNIT OVERHANG BEYOND END POSTS SHALL NOT EXCEED THE LESSER BETWEEN 15" OR HALF OF THE UNIT WIDTH. UNIT SHALL NOT EXTEND BEYOND END OF RAIL.
- CONTRACTOR IS RESPONSIBLE FOR ALL CLEAR HEIGHT REQUIREMENTS. CLEAR HEIGHT IS DEFINED AS THE DISTANCE FROM FINISHED ROOF TO UNDERSIDE OF THE UNIT.
- POST HEIGHT IS DEFINED AS THE DISTANCE FROM THE BASE PLATE TO THE UNDERSIDE OF THE STAND RAIL.

MAXIMUM POST BASE REACTIONS	
Max Base Moment=	175 lb-ft
Max Base Shear=	186 lb
Max Base Uplift=	710 lb
Max Base Compression=	647 lb

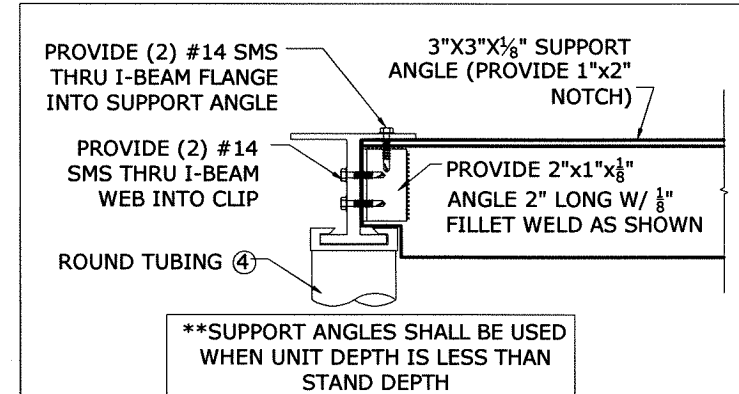

1 SUPPORT ANGLE ATTACHMENT DETAIL
SCALE: NTS 6061-T6 ALUM

CONFIGURATION OPTIONS:

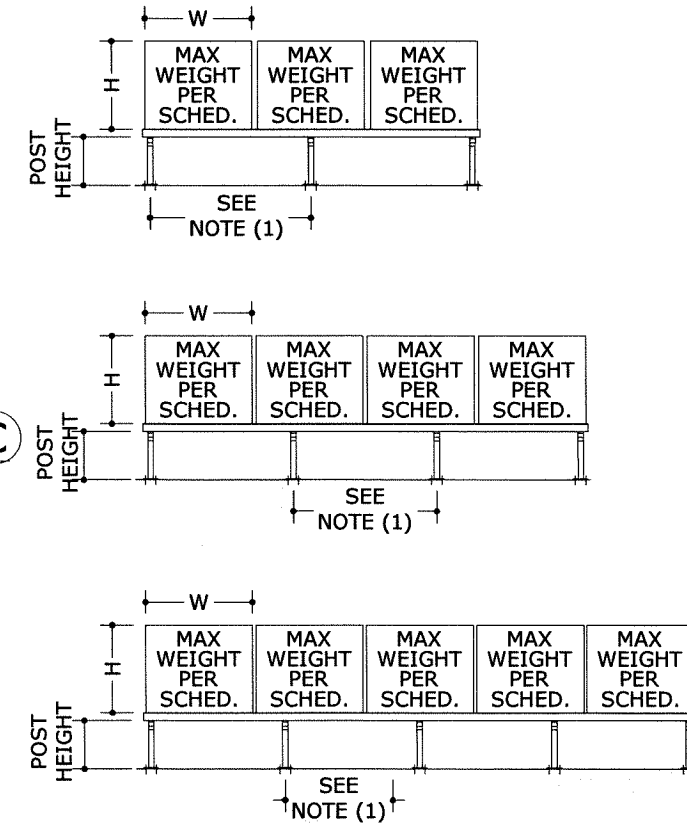
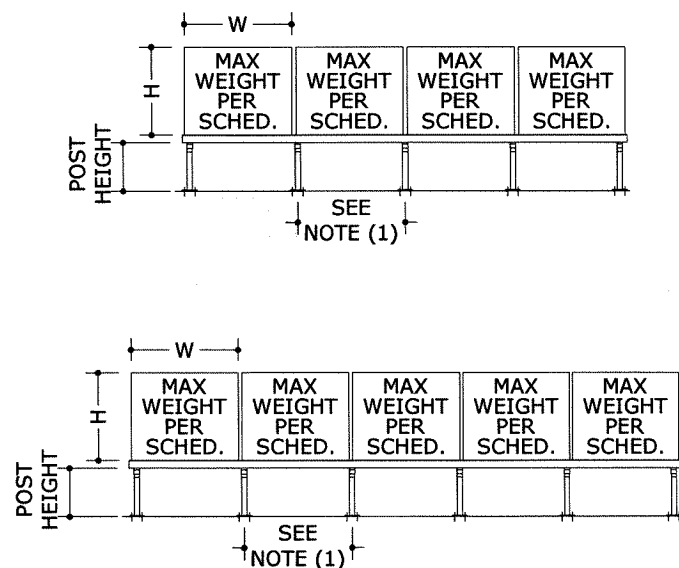
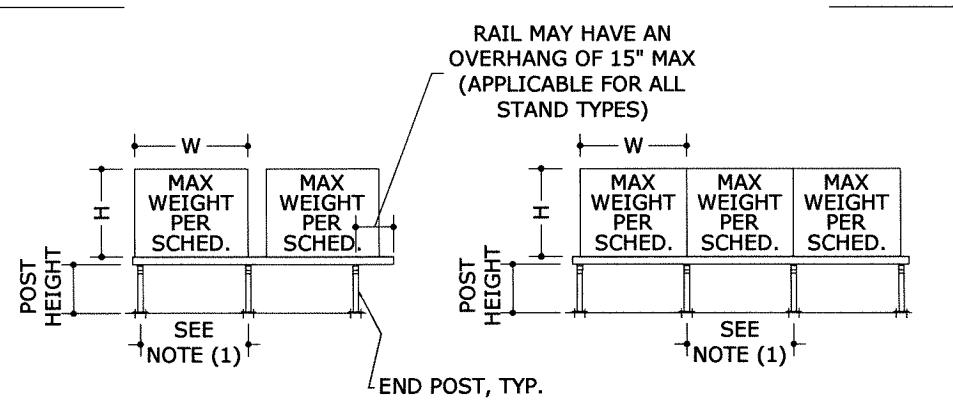
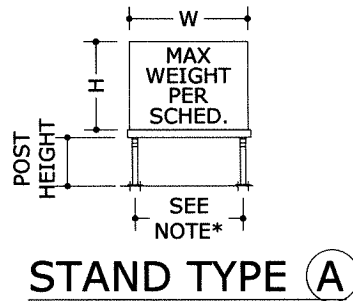

NOTE (1):
MAXIMUM CENTER TO CENTER SPACING BETWEEN POSTS SHALL NOT EXCEED 4'-6". TYPICAL FOR ALL CONFIGURATIONS

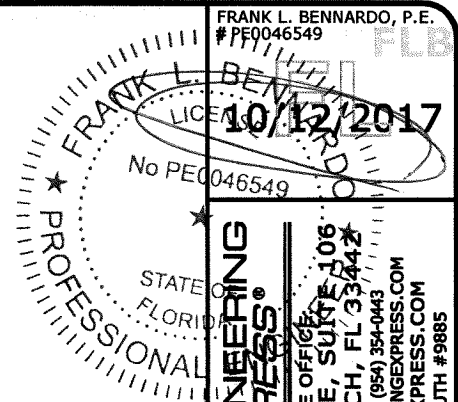

ENGINEERING EXPRESS
CORPORATE OFFICE
160 SW 12th AVE, SUITE 106
DEERFIELD BEACH, FL 33442
P: (954) 354-0660 F: (954) 354-0443
E: HELLO@ENGINEERINGEXPRESS.COM
CERT OF AUTH #988

MIAMI TECH, INC
3611 NW 74TH STREET
MIAMI, FL 33147
PHONE: (305) 693-7054 FAX: (305) 693-6125
ALUMINUM A/C STAND
HVHZ & NON-HVHZ
FLORIDA STATEWIDE APPROVAL FL21464.1

REMARKS	DRWN	CHKD	DATE
INIT ISSUE	RWN	FLB	11/20/16
REV - 2017 FBC	RWN	FLB	10/10/17

THIS DOCUMENT IS THE PROPERTY OF ENGINEERING EXPRESS AND SHALL NOT BE REPRODUCED OR TRANSMITTED IN ANY FORM OR BY ANY MEANS WITHOUT THE WRITTEN PERMISSION OF ENGINEERING EXPRESS. ENGINEERING EXPRESS ASSUMES NO LIABILITY FOR DAMAGES, LOSSES, INJURIES, OR OTHER DAMAGES TO THE USER. DOCUMENT IS NOT PERMITTED AND INVALIDATE OUR CERTIFICATION.

COPYRIGHT ENGINEERING EXPRESS
16-3757
SCALE: NTS
PAGE DESCRIPTION:
2

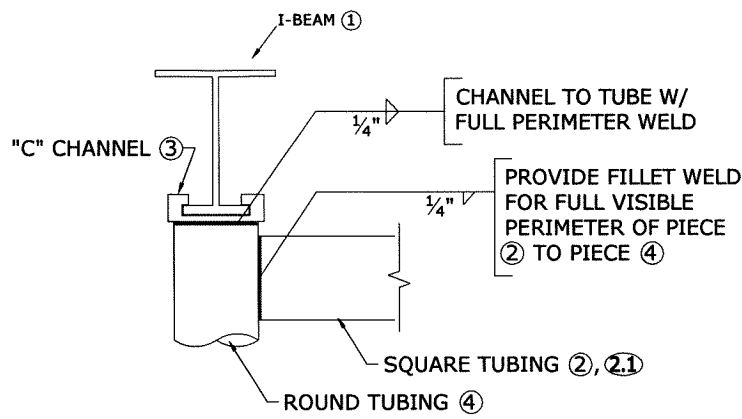

1 FRAME ASSEMBLY DETAIL
SCALE: NTS

ANCHOR SCHEDULE

ANCHOR TYPE	HOST STRUCTURE	ANCHOR DESCRIPTION
1	STEEL	3/8"Ø SAE GRADE 5 SHEET METAL SCREWS WITH 1"Ø MIN. WASHER, TO STRUCTURAL A36 STEEL MEMBERS (3/16" MIN HOST THICKNESS)
2	CONCRETE	3/8"Ø POWERS CARBON STEEL WEDGE-BOLT CONCRETE ANCHOR WITH 1"Ø MIN. WASHER, 2-1/2" EMBEDMENT & 6" MIN EDGE DISTANCE, SEE BASE PLATE COMPONENT #5 (ON SHEET 1) FOR TYPICAL ANCHOR SPACING.
3	WOOD*	*SEE DETAIL 5/3 OR SITE SPECIFIC ENGINEERING IS REQUIRED
4	STEEL	3/8"Ø SAE GRADE 5 THRU-BOLT WITH 1"Ø MIN. WASHER & NUT, TO STRUCTURAL A36 STEEL MEMBERS (3/16" MIN HOST THICKNESS)

ANCHOR NOTES:

- ANCHORS SHALL BE INSTALLED IN ACCORDANCE WITH MANUFACTURERS' RECOMMENDATIONS.
- ENSURE MINIMUM EDGE DISTANCE AS NOTED IN ANCHOR SCHEDULE FOR EACH ANCHOR.
- WOOD HOST STRUCTURE SHALL BE "SOUTHERN PINE" G=0.55 OR GREATER DENSITY. ALL CONCRETE SUBSTRATE SHALL BE UN-CRACKED CONCRETE AND SHALL HAVE MINIMUM COMPRESSIVE STRENGTH OF 3000 PSI. CONCRETE SUBSTRATE THICKNESS SHALL BE GREATER THAN OR EQUAL TO 1.5xANCHOR EMBEDMENT. INSTALL CONCRETE ANCHORS TO UN-CRACKED CONCRETE ONLY.
- MINIMUM EMBEDMENT SHALL BE AS NOTED IN ANCHOR SCHEDULE. MINIMUM EMBEDMENT AND EDGE DISTANCE EXCLUDES ROOFING FINISHES.
- WHERE EXISTING STRUCTURE IS WOOD TRUSSES, EXISTING CONDITIONS MAY VARY. FIELD VERIFY THAT FASTENERS ARE INTO ADEQUATE WOOD TRUSS MEMBERS, NOT INTO PLYWOOD.

FOR USE WITHIN AND OUTSIDE THE HIGH VELOCITY HURRICANE ZONE (HVHZ)

****NOTE:**
ALL UNIT TIE-DOWNS IN THIS DRAWING CERTIFY INSTALLATIONS UP TO 15 FEET MEAN ROOF HEIGHT MAXIMUM. INSTALLATIONS FOR ROOF HEIGHTS GREATER THAN 15 FEET SHALL BE CERTIFIED THROUGH SEPARATE ENGINEERING

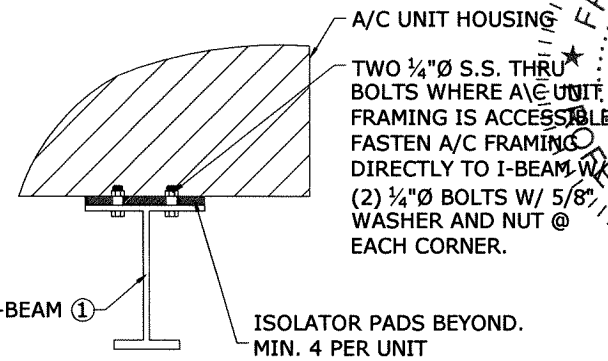

3 ALT. A/C UNIT TIE-DOWN DETAIL**
SCALE: NTS

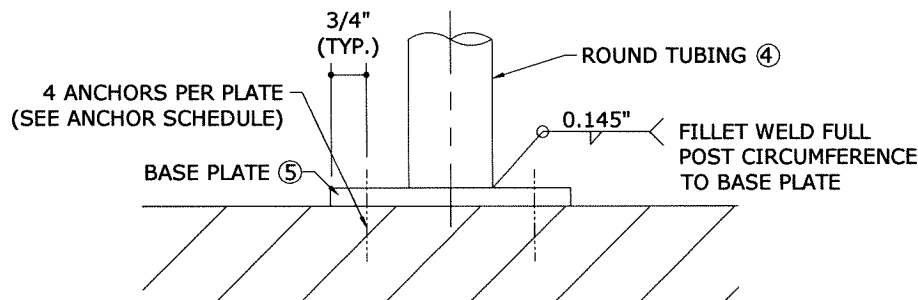

2 BASE PLATE DETAIL (REF DESIGN SCHEDULE)
SCALE: NTS

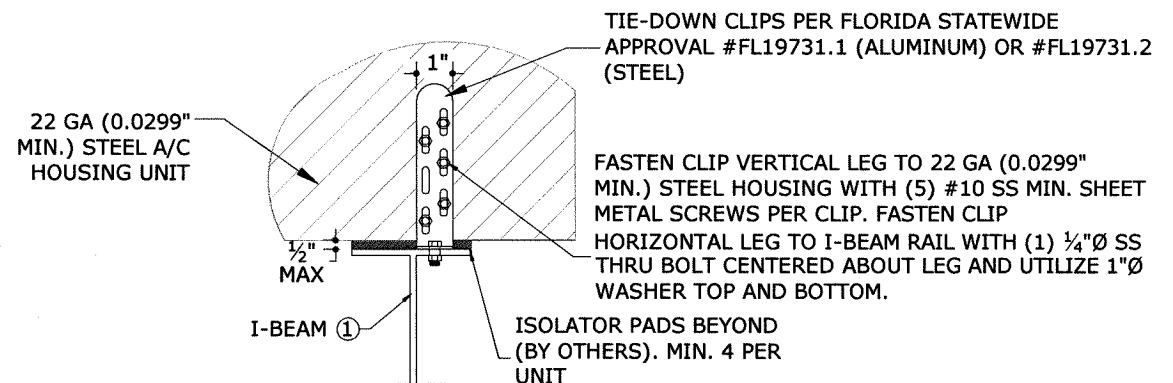

4 A/C UNIT TIE-DOWN DETAIL**
SCALE: NTS

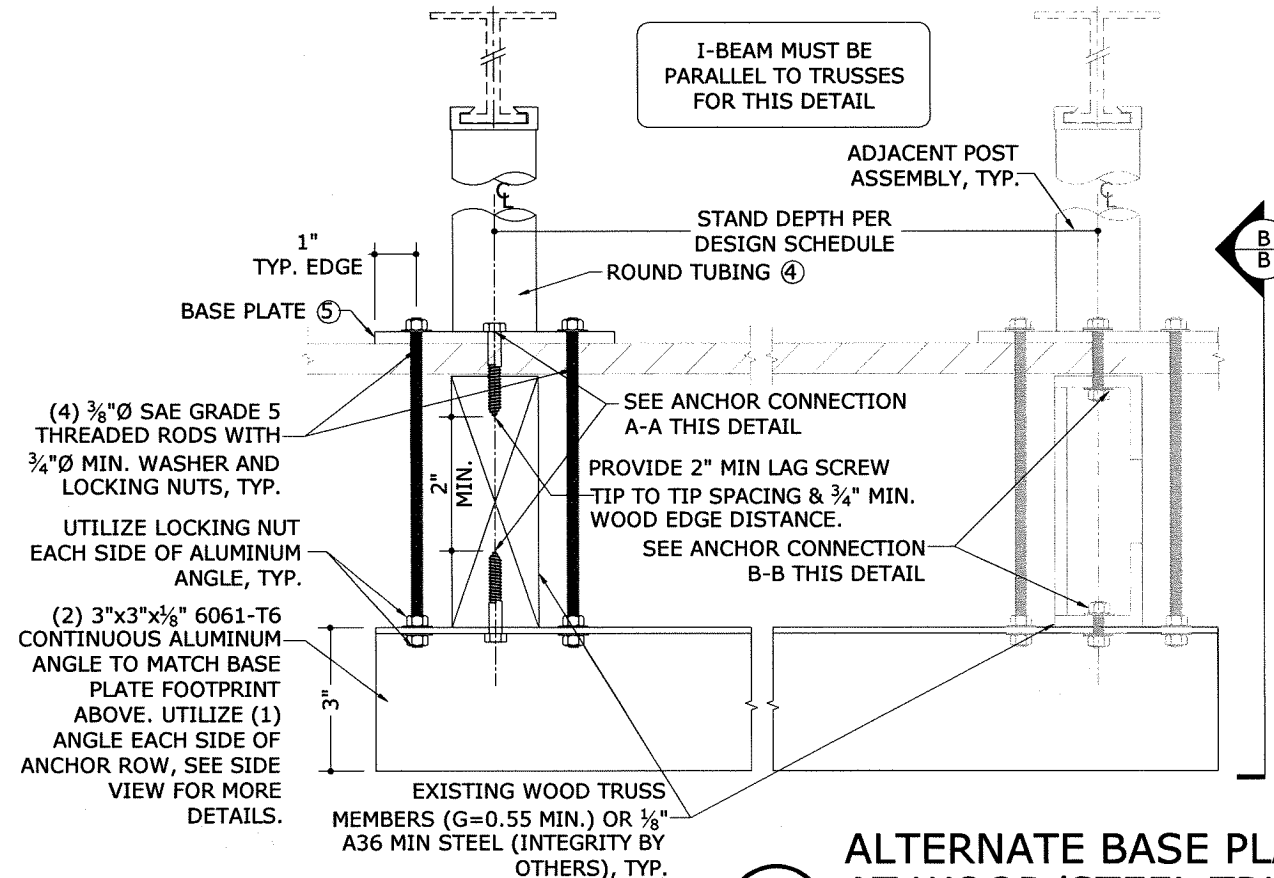

5 ALTERNATE BASE PLATE ATTACHMENT AT WOOD/STEEL TRUSS MEMBERS
SCALE: NTS

ANCHOR A-A (WOOD MEMBER)
ADD (4) 1/4"Ø LAG SCREW, 5/8"Ø MIN. WASHER, 3 1/2" MIN. EMBED, 3/4" MIN. EDGE DISTANCE. UTILIZE (2) TOP AND (2) BOTTOM, TYP.

ANCHOR B-B (STEEL MEMBER)
ADD (4) 3/8"Ø THRU-BOLT, 3/4"Ø MIN. WASHER AND LOCKING NUT. UTILIZE (2) TOP AND (2) BOTTOM, TYP.

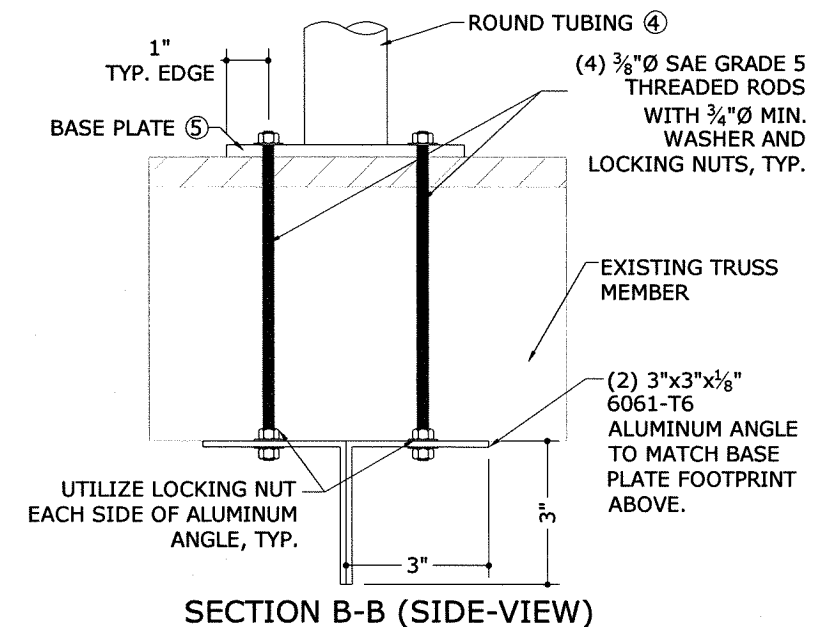

SECTION B-B (SIDE-VIEW)

FRANK L. BENNARDO, P.E.
#PE0046549
10/12/2017
No PE0046549

ENGINEERING EXPRESS
CORPORATE OFFICE:
160 SW 12th Ave, Suite 106
Deerfield Beach, FL 33442
P: (954) 354-0660 F: (954) 354-9983
E: HELLO@ENGINEERINGEXPRESS.COM
ENGINEERINGEXPRESS.COM
CERT OF AUTH #9885

MIAMI TECH, INC
3611 NW 74th Street
MIAMI, FL 33147
PHONE: (305) 693-7054 FAX: (305) 693-6125
ALUMINUM A/C STAND
HVHZ & NON-HVHZ
FLORIDA STATEWIDE APPROVAL FL21464.1

DRWN	CHKD	DATE
RWN	FLB	11/30/16
RWN	FLB	10/10/17

REMARKS
INIT ISSUE
REV - 2017 FBC

THIS DOCUMENT IS THE PROPERTY OF ENGINEERING EXPRESS AND SHALL NOT BE REPRODUCED, COPIED, OR TRANSMITTED IN ANY FORM OR BY ANY MEANS, WITHOUT THE WRITTEN PERMISSION OF ENGINEERING EXPRESS. ALTERATIONS, ADAPTATIONS, HIGH LIFTING, OR OTHER MODIFICATIONS TO THIS DOCUMENT ARE NOT PERMITTED AND WILL VOID OUR CERTIFICATION.

16-3757
COPYRIGHT ENGINEERING EXPRESS

SCALE: NTS
PAGE DESCRIPTION:
3

10/12/2017 - 8:35pm zachr V:\Projects\16-3757 Non - HVHZ Master Plan Sheet\WP\2017 FBC Update\16-3757-Dwg-21464.1.dwg