Standard Construction:
Material:

Main Angle: 1-1/2x1-1/2" 16ga Galvanized Steel

Cross Tube: 1x1" and 13/16" 16ga Galvanized Steel Tube

Guide Angle: 1x1" 26ga Galvanized Steel Angle

Construction:

MIG Welded

Features:

Maintains required 4" clearance from rear wall

Wall mounted for easy installation into tight spaces and over water heaters

Avoids voiding of air handler UL rating since no cabinet penetration is required

Accommodates units up to 30" wide and up to 350 lbs in weight.

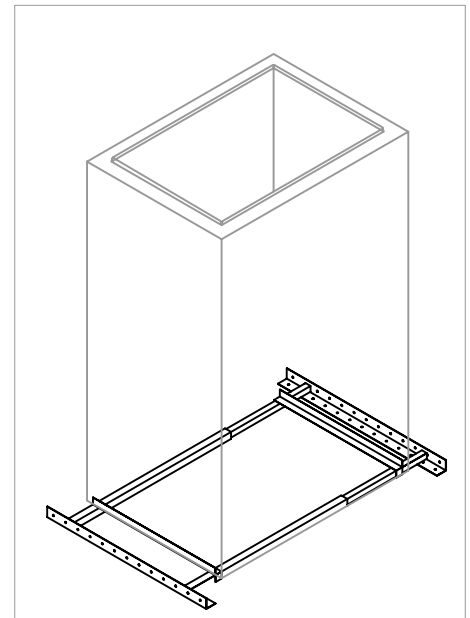

AAWB
Adjustable Air Handler Wall Bracket
 Specifications

NOTE: ALL DRAWINGS SUBJECT TO CHANGE WITHOUT PRIOR NOTICE.