



UNDERWRITERS LABORATORIES INC.  
555 CLASSIFIED  
PRIMARY FIRE DAMPER  
FILE NO. R10967

THE CITY OF NEW YORK 909-89-SM  
CALIFORNIA STATE FIRE MARSHALL 3225-1382:100

**PARTS:**

- 1. BLADES  
(22 GAUGE ASTM A-653 HOT-DIPPED GALVANIZED STEEL SHEET)
- 2. UL LISTED FUSIBLE LINK  
(165°F STANDARD, 212°F OPTIONAL)
- 3. FRAME  
(22 GAUGE ASTM A-653 HOT-DIPPED GALVANIZED STEEL SHEET)
- 4. CERAMIC THERMAL BLANKET  
(REQUIRED ON DAMPERS 70 SQ. IN. AND ABOVE, NON-ASBESTOS)
- 5. SPRING  
(TEMPERED STAINLESS STEEL)

**FEATURES:**

UL FIRE RATED FLOOR/CEILING AND ROOF/CEILING ASSEMBLIES REQUIRE SPECIFICALLY TESTED AND CLASSIFIED CEILING DAMPERS (ALSO KNOWN AS CEILING FIRE DAMPERS OR HEAT RADIATION DAMPERS) TO PROVIDE PROPER PROTECTION WHERE HVAC COMPONENTS PENETRATE THE CEILING MEMBRANE. STANDARD PRIMARY FIRE DAMPERS (1 1/2 AND 3 HOUR) DO NOT PROVIDE THE NECESSARY FIRE AND HEAT PROTECTION.

UL CLASSIFIED MODEL 615 CEILING DAMPER MAY BE SUBSTITUTE FOR EACH 113 SQ. IN. OR LARGER STEEL DUCT OUTLET PROTECTED WITH A HINGED SHEET METAL DAMPER IN ANY FLOOR/CEILING OR ROOF/CEILING DESIGN WITH A RESTRAINED OR UNRESTRAINED ASSEMBLY RATING OF 3 HOURS OR LESS.

THERMAL BARRIER SUPPLIED ON UNITS LARGER THAN 70 SQ. IN. SMALLER SIZES DO NOT REQUIRE A THERMAL BARRIER ON THE BLADES.

SINGLE BUTTERFLY  
4" X 4" MINIMUM / 18" X 18" MAXIMUM

DOUBLE BUTTERFLY  
20" X 20" MINIMUM / 24" X 24" MAXIMUM

OPTIONS: CUSTOM SIZES AVAILABLE

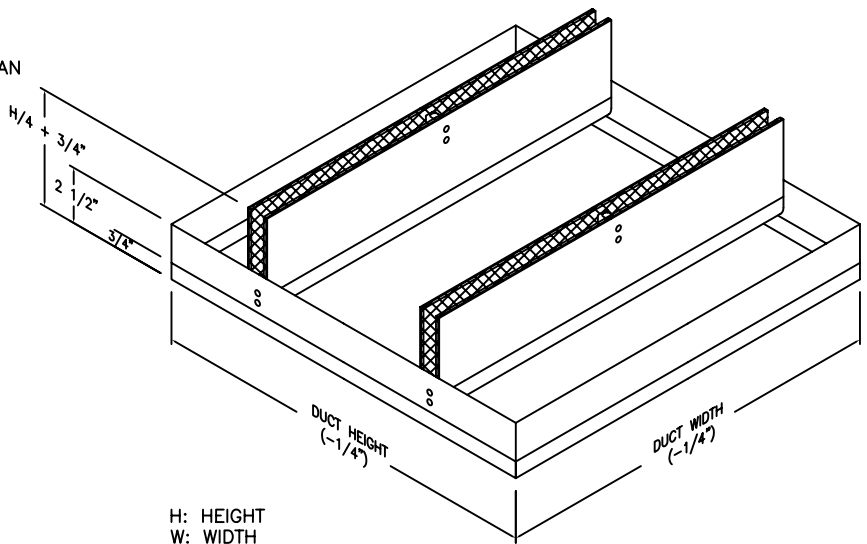
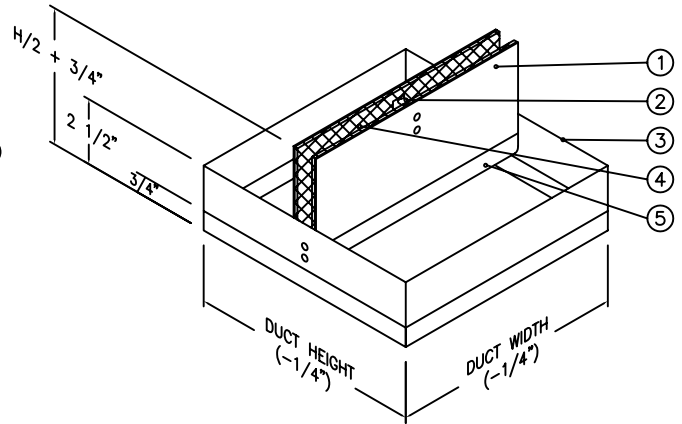

H: HEIGHT  
W: WIDTH

JOB NAME:
LOCATION:
ARCHITECT:
ENGINEER:
CONTRACTOR:
CONTACT MIAMI TECH INC. FOR ADDITIONAL INFORMATION OR WITH SPECIAL REQUIREMENTS. 3611 NW 74TH ST MIAMI, FL 33147 PHONE: 305-693-7054 FAX: 305-693-6152 WEB: WWW.MIAMITECH.COM EMAIL: SALES@MIAMITECH.COM

**615**

SQUARE AND RECTANGULAR CEILING FIRE DAMPER  
PRODUCT SPECIFICATIONS

NOTE: ALL DRAWINGS SUBJECT TO CHANGE WITHOUT PRIOR NOTICE.



**miami tech inc.**

DRAWN BY: AF	DATE: 11/12/07	SCALE: NOT TO SCALE	DRAWING NO.
CHECKED BY: IG	DATE: 11/12/07	REVISION: 1	

615