Miami Tech Inc.

**MODEL 151B
FIRE DAMPER**

INSTALLATION INSTRUCTIONS



The City of New York 909-89-SM
California State Fire Marshall 3225-1382:100

Stock ID: IOM-151B

January, 2003

©2003 Miami Tech Inc., Inc.

Miami, FL

Foreword

This publication details the installation requirements for dynamic application fire dampers as manufactured by Miami Tech Inc.®. Use of this manual for systems or products not manufactured or supplied by Miami Tech Inc.® shall not be applicable.

All products covered by this manual have been tested in accordance with UL555 and are authorized to bear the UL classification mark for fire dampers. Specific Fire Damper model numbers and their corresponding UL file numbers may be found in UL's Fire Resistance Directory.

For specific fire damper location requirements, duct construction and connection or installation practices, refer to the following codes or standards:

NFPA Publications:

NFPA 90A - Standard for the Installation of Air-Conditioning and Ventilation Systems

UL Publications:

UL555 - Standard for Safety, Fire Dampers

SMACNA Publications:

Fire, Smoke and Radiation Damper Installation Guide for HVAC Systems Guide
HVAC Duct Construction Standards - Metal and Flexible

The Installation Instructions found within this manual have been specifically drawn and detailed to meet the requirements of UL555. Some jurisdictions may require additional or different installation methods; therefore, consult with the authority having jurisdiction for specific differences. For these cases, the requirements defined by the authority having jurisdiction will take precedence over the documents contained herein.

Model 151B • 1.5 Hour Single Section Dynamic Fire Damper

HORIZONTAL MOUNTING (FLOOR) (Model 151B)

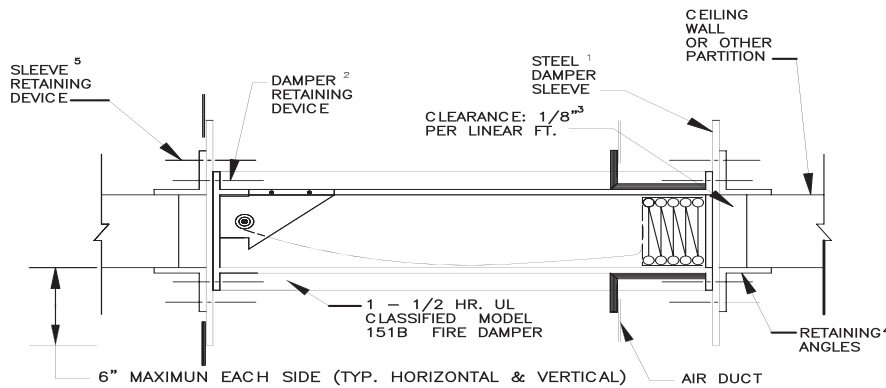

VERTICAL MOUNTING (WALL) (Model 151B)

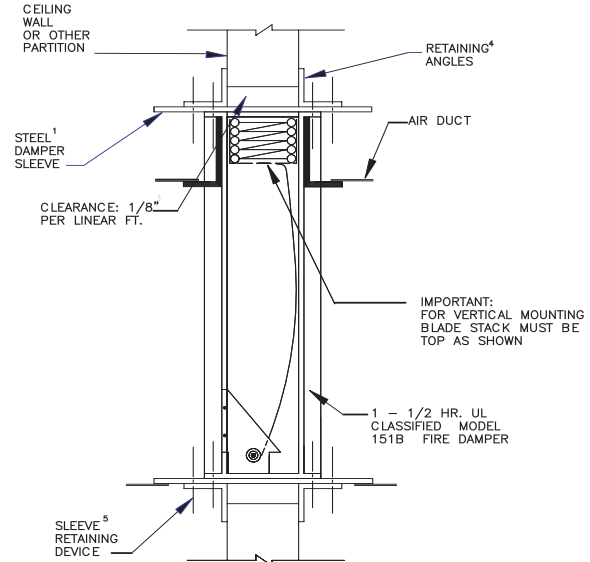

Fusible Link — 165°F

NOTES:

1. Sleeve shall be of the same or heavier gauge as the duct to which it is attached. Gauges shall conform to SMACNA or ASHRAE Duct Standards. When the following duct-sleeve connections are used, minimum gauge of the sleeve shall be 16 gauge on dampers not exceeding 36" wide x 24" high and 14 gauge on larger dampers: (a) angle reinforced standing seam, (b) angle reinforced pocket lock, (c) companion angle, or (d) metal fasteners spaced approximately 16" on center. Refer to the latest edition of UL 555 for connections which may be used in all systems.
2. Damper is secured to sleeve by the use of either 1/4" diameter steel nuts and bolts, No. 10 sheetmetal screws, 1/4" diameter steel rivets, or 1/2" long welds...all of which must be 6" on center and a maximum of 1 3/4" from the ends.
3. Fire dampers shall have clearance of 1/8" per linear foot on width and height. The unit (damper and sleeve) may rest on the bottom of the opening and need not be centered.
4. Retaining angles shall be a minimum of 1 1/2" x 1 1/2" x 16 gauge steel. Angles increase in size proportionally, so that there will be a minimum of 1" overlap on the partition, and angles must also cover corners of opening.
5. The sleeve is retained in the partition opening by the use of either 1/4" diameter steel nuts and bolts, No. 10 sheetmetal screws, 1/4" diameter steel pop rivets or 1/2" long welds...all of which must be 6" on center and no more than 2" from the ends. Devices are to attach angle to sleeve only.
6. This installation is for dampers which are to be installed in masonry walls only. See Alternate Framing Methods on page 5.
7. Connecting ducts shall be terminated at the sleeve or transition collar where a draw-band type breakaway joint is used.
8. Maximum duct size of single section Model 151B unit is 24" wide x 24" high.

What is a Fire Damper?

The National Fire Protection Association (NFPA) Standard 90A defines a fire damper as “a device, installed in an air distribution system, that is designated to close automatically upon detection of heat, to interrupt migratory airflow, and to restrict the passage of flame.”

Types of Curtain Fire Dampers:

Curtain type Fire Dampers are available in three configurations.

Type A



Blades & Frame in Airstream.

Type B

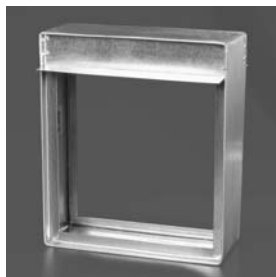

Blades out of Airstream. This provides better free flow area and pressure drop than Type A.

Type C

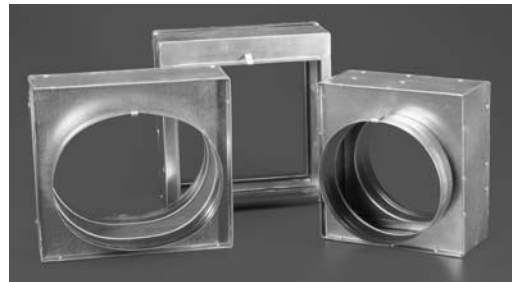

Blades and frame are out of Airstream; primarily used when transitioning to round or square duct. Type C provides maximum pressure drop characteristics with blades and frame out of airstream.

STATIC RATED OR DYNAMIC RATED, WHATS THE DIFFERENCE?



Underwriters Laboratories (UL) Standard for Safety 555 categorizes smoke and fire control systems as either static or dynamic. UL555 defines dampers intended to close under no airflow conditions as dampers for static systems, and dampers intended to close under flow conditions as dampers for dynamic systems.

As of July 1, 2002, all Dynamic Fire Dampers must meet the “new” UL555 Standard. This Standard changes the way Dynamic Fire Dampers are tested. The new Standard requires all manufacturers to retest to a stricter requirement. This insures better designed and built dampers.

Miami Tech Inc. Model 151 has been tested and has passed in both Vertical and Horizontal Installation.

Did you know? ...

Fire Dampers must be mounted in a steel sleeve. The damper and sleeve assembly is held in place by using retaining angles on each side of the wall. Ductwork shall be connected to either side with a “break away” connection. This allows the damper to remain in the wall in the event that ductwork fall during a fire. All necessary mounting products are available from Miami Tech Inc.

Model 150 & 151 • Alternate Framing Methods

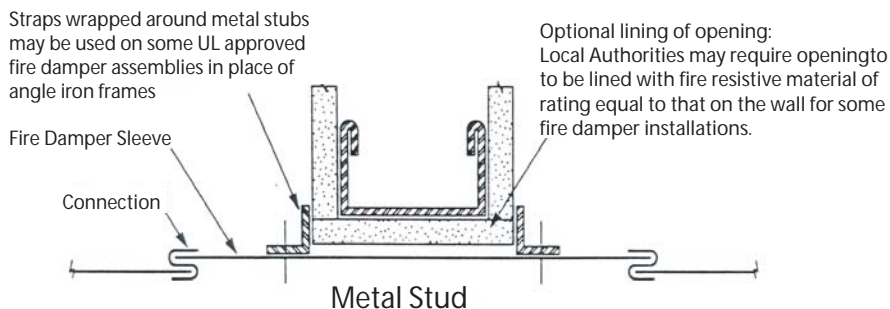
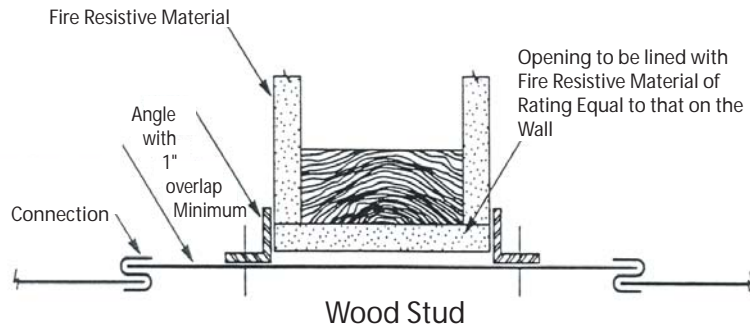
**NOTES:**

1. Thickness and type of fire resistive material may vary with the jurisdiction. Specific framing requirements of openings should be provided in the architectural and structural drawings that are submitted for building permits.
2. Sleeve shall be 14 gauge when the following duct-sleeve connection is: (a) angle reinforced standing seam, (b) angle reinforced pocket, (c) companion angles, (d) metal fasteners spaced approximately 16" on center. Refer to latest edition of UL 555 for connections with may be used in all systems. Gauges shall conform to SMACNA or ASHRAE Duct Standards.
3. Damper is secured to sleeve by the use of either 1/4" diameter steel nuts and bolts, No. 10 sheetmetal screws, 1/4" diameter steel rivets, or 1/2" long welds...all of which must be 6" on center and a maximum of 1 3/4" from the ends.
4. Fire dampers shall have clearance of 1/8" per linear foot on width and height. The unit (damper and sleeve) may rest on the bottom of the opening and need not be centered.
5. Retaining angles shall be a minimum of 1 1/2" x 1 1/2" x 16 gauge steel. Angles increase in size proportionally, so that there will be a minimum of 1" overlap on the partition, and angles must also cover corners of opening.
6. The sleeve is retained in the partition opening by the use of either 1/4" diameter steel nuts and bolts, No. 10 sheetmetal screws, 1/4" diameter steel pop rivets or 1/2" long welds...all of which must be 6" on center and no more than 2" from the ends. Devices are to attach angle to sleeve only.
7. For Horizontal Mount Dampers, the assembly is formed by using a full length 1/8" by 5" wide mullion plate with 1/4" diameter steel nuts and bolts, spaced 6" on center and a maximum of 3/4" from corners attaching frames to mullion plate.
8. For Vertical Mount Dampers, the damper frames are butted together and fastened with either No. 10 x 3/4" long sheetmetal screws, 1/4" diameter steel rivets, 1/4" diameter steel nuts and bolts, or 1/2" long welds...all of which must be spaced at 4" on center and maximum of 3/4" from corners of dampers.
9. Connecting ducts shall be terminated at the sleeve.
10. Maximum duct size of single section vertical only unit is 24" wide x 24" high.