

**BOOTCLIP
INSTALLATION**

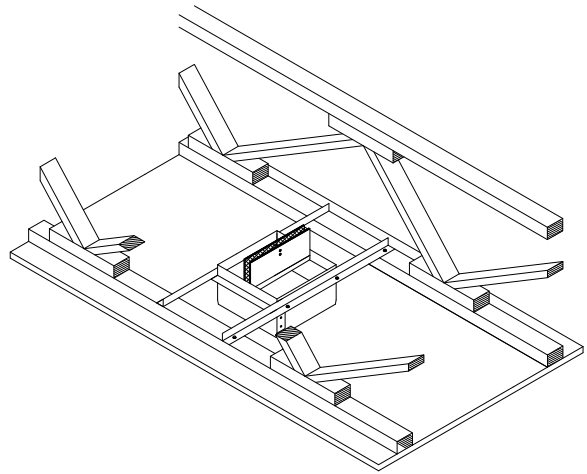

**HANGER ANGLE
INSTALLATION**

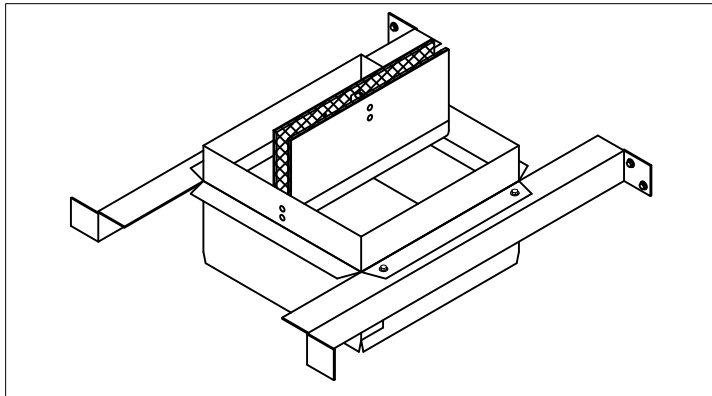

"BETWEEN TRUSS" ALTERNATE MOUNTING



UNDERWRITERS LABORATORIES INC.
555 CLASSIFIED
PRIMARY FIRE DAMPER
FILE NO. R10967

INSTRUCTIONS:

1. Before installing Damper CRPD, open the blades and hook the fusible link over the link catch on the opposite blade.
2. Damper can be supported with two standard 26ga boot clips snapped securely onto two flanges on opposite sides of the damper assembly. The boot clip shall be fastened at each flange/boot clip joint with (2) #8 x 3/4" SMS, and fastened at each end to the underside of the trusses with minimum #6 common nails or #8 wood screws, 2" long (min). Only one connection per end required, OR
3. Damper can be supported by 1"x1" 26ga hanger angles. Measure the actual truss centers and add approx 6" to determine straight angle lengths. (2) required per box. Establish the location of the gypsum flange and fasten the (2) hangers to the box with (2) minimum #8 x 3/4" sheet metal screws or 3/16" dia rivets for each hanger angle, and attach each end of each angle to the top side of the trusses with minimum #6 common nails or #8 wood screws, 2" long (min), OR
4. Damper can be supported with standard 26ga RC channel, either existing or user-installed. For flange to RC channel joint min (2) #8 x 3/4" SMS, and RC channel to truss/joist attachment min (1) #8x2" min wood screw on each end of each RC channel, OR
5. Damper can be supported between trusses with (2) 1 1/2"x1 1/2"x16ga angles. Angles shall be notched and folded out 90 degrees as in the illustration above, so that folded edges sit flush against the insides of the trusses, away from damper. Flush edges to be fastened at each end to the side of the trusses with minimum #6 common nails or #8 wood screws, 2" long (min). (2) connections per end required. Damper shall be affixed to angles with (2) #8 x 3/4" SMS per clip/angle.

IMPORTANT: bolts, rivets, screws, etc., used to install the damper or grille **MUST NOT INTERFERE WITH DAMPER BLADE OPERATION.**

**CRPD
CEILING RADIATION PLENUM DAMPER
INSTALLATION INSTRUCTIONS**



DRAWN BY: AV

DATE: 6/20/2013

SCALE: NOT TO SCALE

DRAWING NO.

CHECKED BY: IG

DATE:

REVISION: A

CRPD-IOM

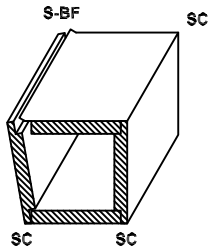
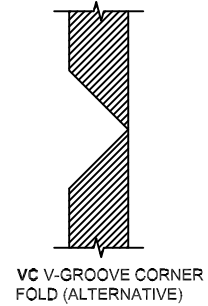
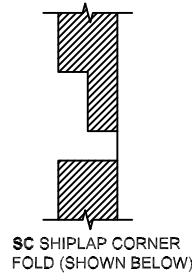
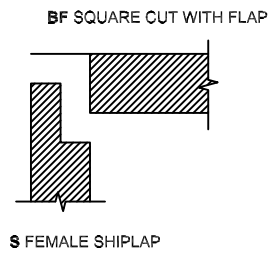
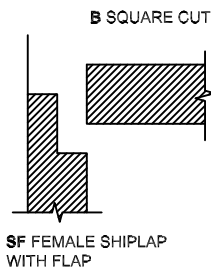

1-PIECE DUCT CONSTRUCTION

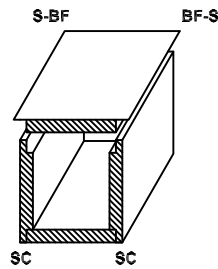

2-PIECE "U" DUCT CONSTRUCTION

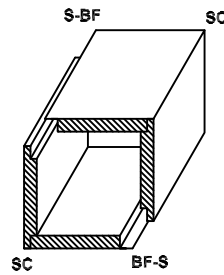

2-PIECE "L" DUCT CONSTRUCTION

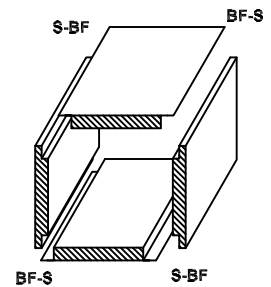

4-PIECE DUCT CONSTRUCTION

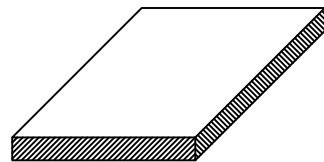

PLENUM TOP

NOTES:

1. Fiberglass ductboard shall be UL 181 listed and have a density of 4 lbs per cubic foot and a minimum thickness of 7/8". Can be R6 or R8 insulation factor. Duct board shall include foil scrim.
2. Edge and corner preparation shall be in accordance with details shown above. Plenum top shall be fabricated and attached using similar method, S-BF or BF-S.
3. Corner sealing tape shall be UL 181 and a minimum of 2" wide.
4. Plenum shall be attached to the CRPD frame using UL 181 listed tape. Duct board shall be applied on damper frame above mounting flange.
5. Plenum box may be variable in size, but must not interfere with damper blade operation.
6. Refer to page 1 for ceiling damper installation details.

**CRPD
CEILING RADIATION PLENUM DAMPER
PLENUM ASSEMBLY INSTRUCTIONS**



DRAWN BY: AV

DATE: 6/20/2013

SCALE: NOT TO SCALE

DRAWING NO.

CHECKED BY: IG

DATE:

REVISION: A

CRPD-IOM