

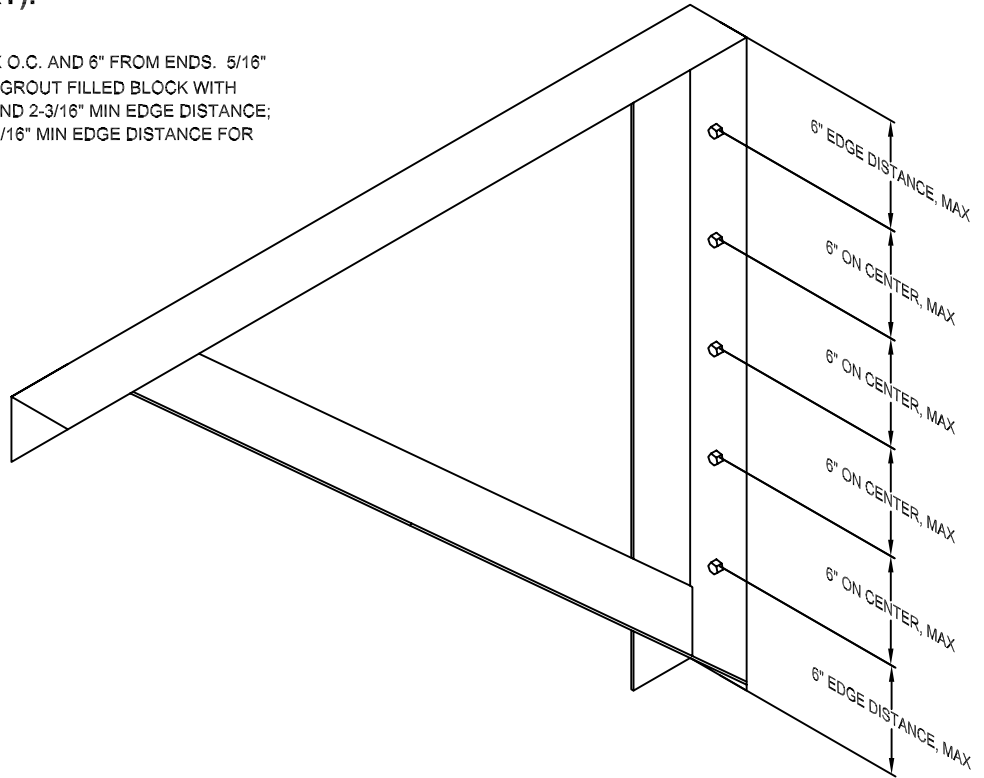

ANCHOR TYPE A (MASONRY):

(1) ROW OF (5) ANCHORS, SPACED 6" MAX O.C. AND 6" FROM ENDS. 5/16" ITW TAPCONS TO 3000PSI CONCRETE OF GROUT FILLED BLOCK WITH 1-3/4" EMBEDMENT, 3-3/4" MIN SPACING, AND 2-3/16" MIN EDGE DISTANCE; 4" MIN EDGE DISTANCE FOR G.F.B. OR 2-3/16" MIN EDGE DISTANCE FOR 3KSI CONCRETE.



ANCHOR TYPE B (WOOD):

(2) ROW OF (5) ANCHORS, STAGGERED, SPACED 6" MAX O.C. AND 6" FROM ENDS. 5/16" LAG BOLTS TO WOOD (G=0.55 MIN), WITH 1-1/2" MIN EMBEDMENT, 3/4" MIN EDGE DISTANCE, 1-1/4" MIN SPACING

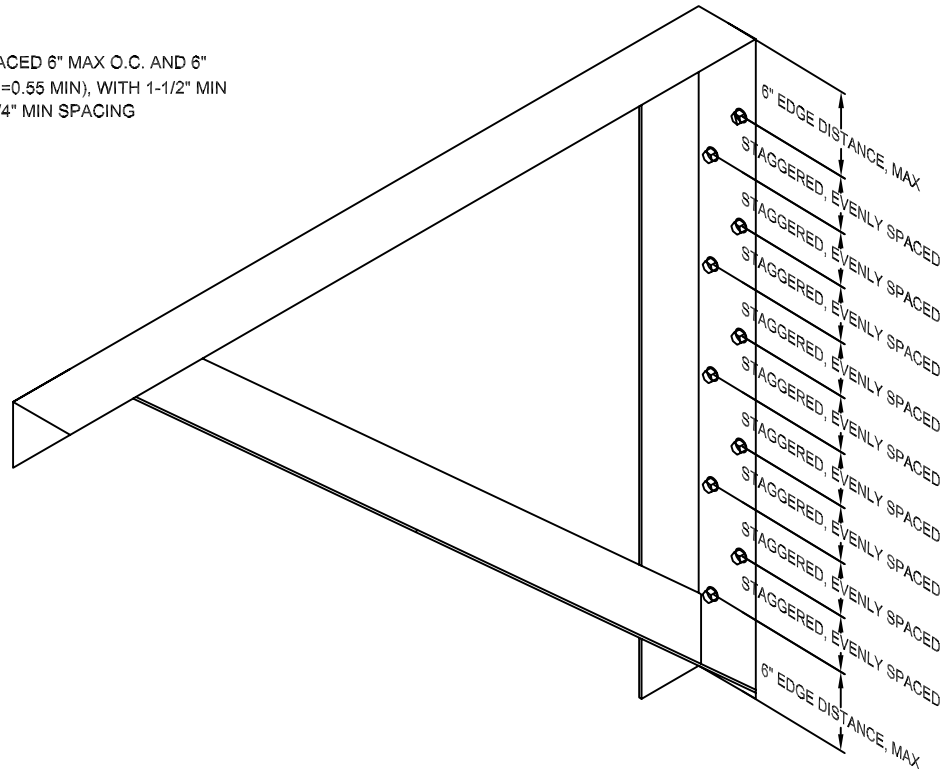

AWB ANCHOR SCHEDULE

ALUMINUM WALL BRACKET
ANCHORING INSTRUCTIONS



DRAWN BY:	AV
CHECKED BY:	IV

DATE:	9-17-10
DATE:	

SCALE:	NOT TO SCALE
REVISION:	1

DRAWING NO.	AWB IOM
-------------	---------

NOTE: ALL DRAWINGS SUBJECT TO CHANGE WITHOUT PRIOR NOTICE.