

Technical Evaluation Report

DIVISION: 23 08 00 – COMMISSIONING OF HVAC

THIS DOCUMENT CONTAINS (15) PAGES. THE FIRST PAGE MUST BEAR AN ORIGINAL SIGNATURE & SEAL OF THE CERTIFYING PE TO BE VALID FOR USE. COPIES NOT VALID FOR PERMIT.

(Subject to Renew May 1, 2022 or next code cycle)

EVALUATION SUBJECT: Lennox Merit Series, Elite Series, & Dave Lennox Signature Collection
TER-20-32211
REPORT HOLDER:

 LENNOX INDUSTRIES
 2100 LAKE PARK BLVD
 RICHARDSON, TX 75080, USA
 1-866-953-6609 | WWW.LENNOX.COM

 Florida Building Code Sixth & Seventh Editions (2017 & 2020)
 International Building Code (2012, 2015 & 2018)

SCOPE OF EVALUATION (compliance with the following codes):
THIS IS A STRUCTURAL (WIND) PERFORMANCE EVALUATION ONLY. NO ELECTRICAL OR TEMPERATURE PERFORMANCE RATINGS OR CERTIFICATIONS ARE OFFERED OR IMPLIED HEREIN.

This Product Evaluation Report is being issued in accordance with the requirements of the International Building Code (2012, 2015, & 2018) and the Florida Building Code Sixth & Seventh Editions (2017 & 2020) per ASCE 7, FBC Building Ch. 16, FBC Building Section 104.11, FBC Existing Building Sections 707.1 and 707.2, FBC Residential M1202.1 and M1301.1, FMC 301.15, FS 471.025, and Broward County Administrative Provisions 107.3.4. The product noted on this report has been tested and/or evaluated as summarized herein.

NOTE: THE GRAPHICAL DEPICTIONS IN THIS REPORT ARE FOR ILLUSTRATIVE PURPOSES ONLY AND MAY DIFFER IN APPEARANCE.
OPTIONS:

This evaluation is valid for all Lennox Merit, Elite, and Dave Lennox Signature Collection units described herein. Any structural changes outside of the design as described herein would void this certification.

STRUCTURAL PERFORMANCE:

Models referenced herein are subject to the following design limitations:

 Maximum Rated Wind Pressures*:
± 148 psf Lateral, 117 psf Uplift

- Required design pressures shall be determined on a site-specific basis in accordance with ASCE 7 and applicable sections of the building code(s) being referenced in accordance with ASD methodology.
- Required design pressures shall be less than or equal to the maximum pressures listed herein.
- *Maximum Rated Wind Pressures indicate the maximum pressures that all units listed herein are approved for. Valid for at-grade and rooftop applications. See limitations herein.
- Site-specific wind analysis may produce alternate limitations provided maximum rated wind pressures stated herein are not exceeded.

IN ACCORDANCE WITH THESE CODES EACH OF THESE REPORTS MUST BEAR THE ORIGINAL SIGNATURE & RAISED SEAL OF THE EVALUATING ENGINEER.
SUBSTANTIATING DATA:
• Product Evaluation Documents

Substantiating documentation has been submitted to provide this TER and is summarized in the sections below.

• Structural Engineering Calculations

Structural engineering calculations have been prepared which evaluate the product based on rational analysis to qualify the following design criteria:

- Maximum unit dimensions and weight range certified herein
- Maximum allowable lateral and uplift pressures certified herein
- Tie-down clip/strap configuration and anchor spacing
- Anchor capacity for various substrates

Calculation summary is included in this TER and appears below. NOTE: No 33% increase in allowable stress has been used in the design of this product.

INSTALLATION:

The product(s) listed above shall be installed in strict compliance with this TER & manufacturer-provided model specifications.

The product components shall be of the material specified in the manufacturer-provided product specifications. All fasteners and anchors shall be installed in accordance with the applicable provisions specified herein in addition to the anchor/fastener manufacturers' published installation instructions.

LIMITATIONS & CONDITIONS OF USE:

Use of this product shall be in strict accordance with this TER as noted herein. Adjustment factors noted herein and the applicable codes must be considered, where applicable. Installation shall conform to the minimum standards stated in the referenced building code(s) in addition to tie-down details and limitations stated herein. See final page for complete limitations & conditions of use.

UNIT CASING MATERIALS:

Unit casing materials and fasteners are dependent on the Product Line. See next page for further descriptions.

TERMINOLOGY:

See list of abbreviations on the final page of this report.

VISIT ECALC.IO/32211

FOR ENGINEER CERTIFIED ORIGINALS & MORE INFORMATION ABOUT THIS DOCUMENT OR SCAN THE QR CODE TO THE RIGHT >

 VISIT ENGINEERINGEXPRESS.COM/STORE FOR ADDITIONAL PLANS, REPORTS & RESOURCES

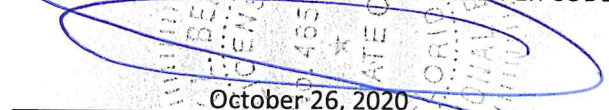
ORIGINAL SIGNATURE AND RAISED SEAL OR DIGITAL SEAL REQUIRED TO BE VALID PER CODE:

 Frank Bennardo, P.E., SECB If Checked, Certifying Engineer and PE #
 FL PE #0046549 FLCA #9885 Appear Above

DIGITAL SEAL NOTICE: IF THIS DOCUMENT IS DIGITALLY SIGNED, THIS SHEET IS PART OF A DIGITALLY SIGNED FILE. IT SHALL REMAIN IN DIGITAL FORMAT, SHALL BE VERIFIED BY ELECTRONIC MEANS, & PRINTED COPIES OF THIS DOCUMENT ARE NOT CONSIDERED SIGNED AND SEALED. VISIT ECALC.IO/DS FOR MORE INFORMATION.

PRINTED DOCUMENT NOTICE: IF THIS DOCUMENT IS PRINTED & DOES NOT CONTAIN AN ENGINEER'S ORIGINAL SIGNATURE & SEAL, THIS DOCUMENT IS VOID & NOT VALID FOR USE. PHOTOCOPIES ARE NOT PERMITTED FOR USE.

Copyright © Engineering Express® All Rights Reserved

UNIT CASING MATERIALS, CONTINUED

Product Line	Unit Casing Materials	Fastener Information
Merit Series	Unit Base: 18 GA, Fy = 15 ksi min. galv. EDDS steel Top Panel: 18 GA, Fy = 25 ksi min. galv. DDS steel Control Box: 18 Ga, Fy = 30 ksi min. galv. CS Type B steel Control Box Cover, Control Box Bottom (4 Sided Unit): 18 Ga, Fy = 20 ksi min. galv. DDS steel Corner Posts, Mullion, Piping Panel: 24 Ga, Fy = 30 ksi min. galv. CS Type B steel Louvered Panels, Coil Guard: 24 GA, Fy = 30 ksi min. galv. CS Type B steel	Unit casing components are fastened together with #8-18, 1575 lb min. tensile strength (ultimate) and 1000 lb min. shear strength (ultimate) SMS.
Elite Series	Unit Base, Top Panel: 18 GA, Fy = 15 ksi min. galv. EDDS steel Control Box: 18 Ga, Fy = 30 ksi min. galv. CS Type B steel Control Box Cover: 20 Ga, Fy = 20 ksi min. galv. DDS steel Control Box Bottom (4 Sided Unit): 20 Ga, Fy = 25 ksi min. galv. CS Type C steel Corner Posts, Mullion, Piping Panel: 20 Ga, Fy = 30 ksi min. galv. CS Type B steel Louvered Panels, Coil Guard: 22 GA, Fy = 30 ksi min. galv. CS Type B steel	
Dave Lennox Signature Collection	Unit Base, Top Panel: 18 GA, Fy = 15 ksi min. galv. EDDS steel Control Box, Control Box Cover: 18 Ga, Fy = 30 ksi min. galv. CS Type B steel Corner Posts, Mullion, Piping Panel: 20 Ga, Fy = 30 ksi min. galv. CS Type B steel Louvered Panels, Coil Guard: 22 GA, Fy = 30 ksi min. galv. CS Type B steel	

NOTE: See manufacturer for more information on unit construction.

MODEL INFORMATION

See Next Pages for Additional Models / Product Lines

Product Line: Merit Series				
Model Number	Coil Protection	Unit Width (in)	Unit Depth (in)	Unit Height (in)
ML14XC1-018*	Louver	24.25	24.25	29.25
ML14XC1S018*				
14ACX-018*				
14ACXS018*				
16ACX-024*				
16HPX-024*	Louver	24.25	24.25	33.25
ML14XC1-024*	Louver	28.25	28.25	29.25
ML14XC1-024*				
ML14XC1-036*				
ML14XC1S036*				
14ACX-024*				
14ACXS024*				
16ACX-036*				
ML14XC1-036*	Louver	28.25	28.25	33.25
ML14XC1S036*				
ML16XP1-024*				
ML16XP1-030*				
14ACX-042*				
14ACXS042*	Louver	28.25	28.25	37.25
ML14XC1-030*				
ML14XC1S030*				
ML14XC1-041*				
ML14XC1-042*				
ML14XC1S042*				
ML14XC1-048*				
ML14XP1-036*				
ML14XP1-036*				
ML14XP1-036*				
14ACX-030*				
14ACXS030*				
14ACX-036*				
14ACXS036*				
14ACX-041*				
14ACX-048*				
16ACX-048*				
ML14XP1-018*	Louver	28.25	28.25	43.25
ML14XP1-024*				
ML14XP1-030*				
ML16XP1-018*				

Product Line: Merit Series				
Model Number	Coil Protection	Unit Width (in)	Unit Depth (in)	Unit Height (in)
ML14XC1-047*	Louver	32.25	32.25	33.25
ML16XP1-036*				
16HPX-036*				
16HPX-048*				
14ACX-047*				
14ACX-060*				
ML14XP1-042*	Louver	32.25	32.25	37.25
ML14XP1-042*				
ML14XP1-042*				
ML14XP1-048*				
ML14XP1-048*				
ML14XP1-048*				
14ACX-059*				
ML14XC1-059*	Louver	32.25	32.25	43.25
ML14XC1-060*				
ML14XP1-060*				
ML14XP1-060*				
ML14XP1-060*				
ML16XP1-042*				
ML16XP1-048*				
ML16XP1-060*				
16ACX-060*				
16HPX-060*				
TSA036S*				
TSA036S*				
TSA036S*				
TPA036S*	Wire Guard	24.25	24.25	33.25
TPA036S*				
TSA042S*	Wire Guard	28.25	28.25	29.25
TSA042S*				
TSA042S*				
TSA042S*				
TPA036H*				
TPA036H*				

MODEL INFORMATION NOTES:

All unit net weights shall be between 100 lb and 375 lb. Model numbers, dimensions, and weights listed herein are based on information provided by the client. Please contact Report Holder and/or manufacturer for more information. Louver directions may be horizontal or vertical. See herein for unit views and definitions of dimensions. Model number characters following the asterisk (*) do not pertain to this structural certification and may be any combination of numbers or characters. See next page for link to full list of model numbers without asterisks.

MODEL INFORMATION, CONTINUED

See Previous / Next Page for Additional Models / Product Lines

Product Line: Merit Series				
Model Number	Coil Protection	Unit Width (in)	Unit Depth (in)	Unit Height (in)
TSA060S*	Louver	28.25	28.25	33.25
TSA060S*				
TSA060S*				
TSA060S*				
TPA036H*				
TPA036H*				
TSA048S*	Louver	28.25	28.25	37.25
TSA048S*				
TSA048S*				
TSA048S*				
TPA042H*	Louver	32.25	32.25	37.35
TPA042H*				
TPA042H*				
TPA042H*				
TPA048H*				
TPA048H*				
TPA048H*				
TPA048H*				
TPA060H*	Louver	32.25	32.25	43.25
TPA060H*				
TPA060H*				
TPA060H*				

Product Line: Dave Lennox Signature Collection				
Model Number	Coil Protection	Unit Width (in)	Unit Depth (in)	Unit Height (in)
XP21-024*	Louver	39.5	35.5	37
XP21-036*				
XP25-024*				
XP25-036*				
SL18XP1-024*				
SL18XP1-030*				
SL18XC1-030*	Louver	39.5	35.5	41
SL18XC1-036*				
SL18XC1-042*				
SL18XP1-036*				
SL18XP1-042*	Louver	39.5	35.5	47
SL18XC1-024*				
SL18XC1-048*				
SL18XC1-060*				
SL18XP1-048*				
SL18XP1-060*				
SL28XCV-024*				
SL28XCV-036*				
SL28XCV-048*				
SL28XCV-060*				
XC21-024*				
XC21-036*				
XC21-048*				
XC21-060*				
XP21-048*				
XP21-060*				
XC25-024*				
XC25-036*				
XC25-048*				
XC25-060*				
XP25-048*				
XP25-060*				

MODEL INFORMATION NOTES:

All unit net weights shall be between 100 lb and 375 lb. Model numbers, dimensions, and weights listed herein are based on information provided by the client. Please contact Report Holder and/or manufacturer for more information. Louver directions may be horizontal or vertical. See herein for unit views and definitions of dimensions. Model number characters following the asterisk (*) do not pertain to this structural certification and may be any combination of numbers or characters.

VISIT ECALC.IO/32211

FOR A LIST OF APPROVED MODEL NUMBERS STATED IN FULL (NO ASTERISKS), OR SCAN THE QR CODE TO THE RIGHT >



MODEL INFORMATION, CONTINUED

See Previous Pages for Additional Models / Product Lines

Product Line: Elite Series				
Model Number	Coil Protection	Unit Width (in)	Unit Depth (in)	Unit Height (in)
EL16XC1-018*	Louver	28	27	31
XP16-024*	Louver	28	27	35
EL18XCV-024*				
EL18XCVS024*				
EL18XCV-036*				
EL18XCVS036*				
EL18XPV-024*				
EL18XPV-036*				
EL16XC1-024*				
EL16XC1-036*				
EL16XC1S036*				
XC16-036*				
XC16S036*				
SSB036H*				
SSB036H*				
EL16XC1-036*	Louver	35	30.5	35
EL16XC1S036*				
EL16XC1-041*				
EL15XP1-018*				
EL15XP1-024*				
EL15XP1-030*				
EL16XP1-024*				
EL16XP1-030*				
XC16-048*	Louver	35	30.5	39
XC16S048*				
EL16XC1-030*				
EL16XC1-042*				
EL16XC1-048*				
SSB048H*				
SSB048H*				
EL15XP1-036*				

Product Line: Elite Series								
Model Number	Coil Protection	Unit Width (in)	Unit Depth (in)	Unit Height (in)				
XC16-024*	Louver	35	30.5	45				
XC16S024*								
EL16XP1-018*								
EL18XCV-048*								
EL18XCVS048*								
EL18XCVS060*								
EL18XPV-048*								
EL18XPV-060*								
EL16XC1-047*	Louver	39.5	35.5	35				
EL16XC1-060*								
XP16-036*								
SPB036H*								
XP16-048*								
SPB048H*								
EL16XP1-036*								
XC20-024*					Louver	39.5	35.5	39
XC20-036*								
EL15XP1-042*								
EL15XP1-048*								
XP20-024*								
XP20-036*								
XC16-060*	Louver	39.5	35.5	45				
XC16S060*								
SSB060H*								
SSB060H*								
XP16-060*								
SPB060H*								
EL15XP1-060*								
EL16XP1-042*								
EL16XP1-048*								
EL16XP1-060*								
EL18XCV-060*								
XC20-048*								
XC20-060*								
XP20-048*								
XP20-060*								

MODEL INFORMATION NOTES:

All unit net weights shall be between 100 lb and 375 lb. Model numbers, dimensions, and weights listed herein are based on information provided by the client. Please contact Report Holder and/or manufacturer for more information. Louver directions may be horizontal or vertical. See herein for unit views and definitions of dimensions. Model number characters following the asterisk (*) do not pertain to this structural certification and may be any combination of numbers or characters. See previous page for link to full list of model numbers without asterisks.

CABINET TYPES, VIEWS, & DIMENSIONS

NOTE: See next page for "Wire Guard Units: Merit Series" cabinet type

LOUVER UNITS: MERIT SERIES

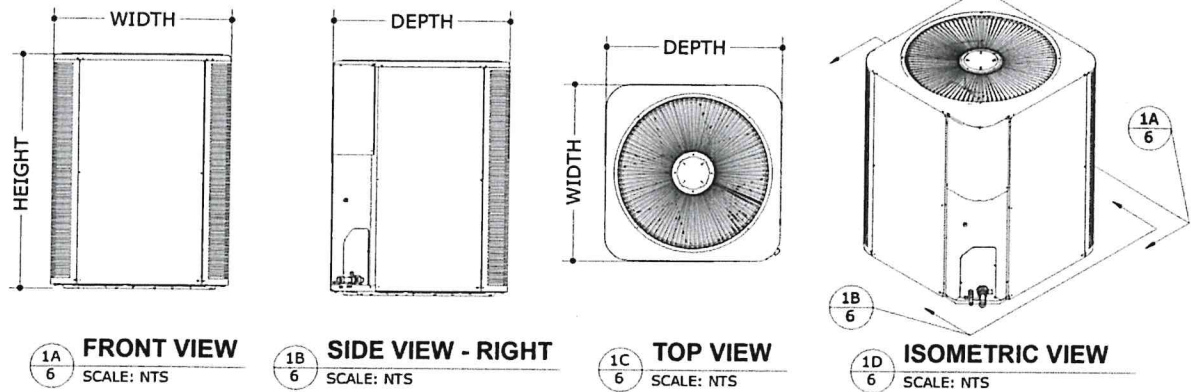

NOTE: Unit depictions in Details 1A through 1D are for illustrative purposes only. Actual units may vary slightly in appearance. Louvers on wall panels are not shown. Louver direction may be horizontal or vertical. This Cabinet Type is applicable for Merit Series - Louver units (see "Model Information" on pages 3 through 5 for model designations).

LOUVER UNITS: ELITE SERIES

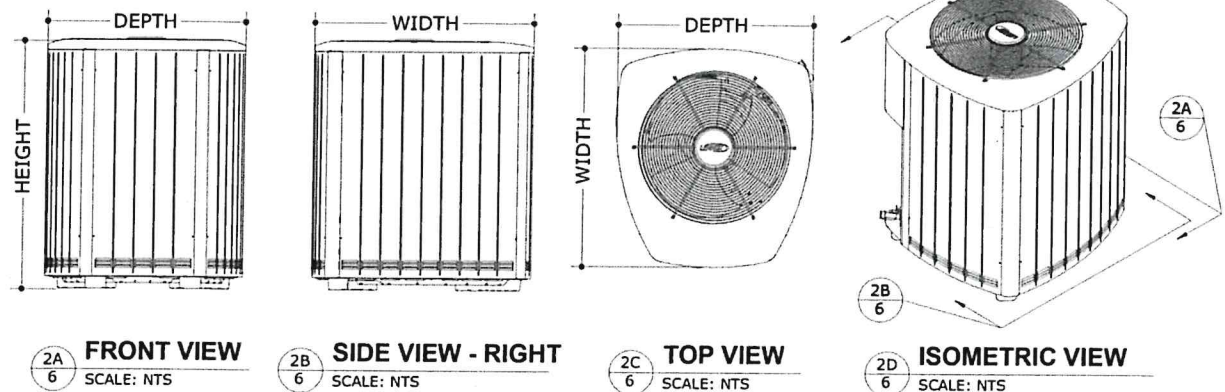

NOTE: Unit depictions in Details 2A through 2D are for illustrative purposes only. Actual units may vary slightly in appearance. Louvers on wall panels are not shown. Louver direction may be horizontal or vertical. This Cabinet Type is applicable for Elite Series - Louver units (see "Model Information" on pages 3 through 5 for model designations).

LOUVER UNITS: DAVE LENNOX SIGNATURE COLLECTION

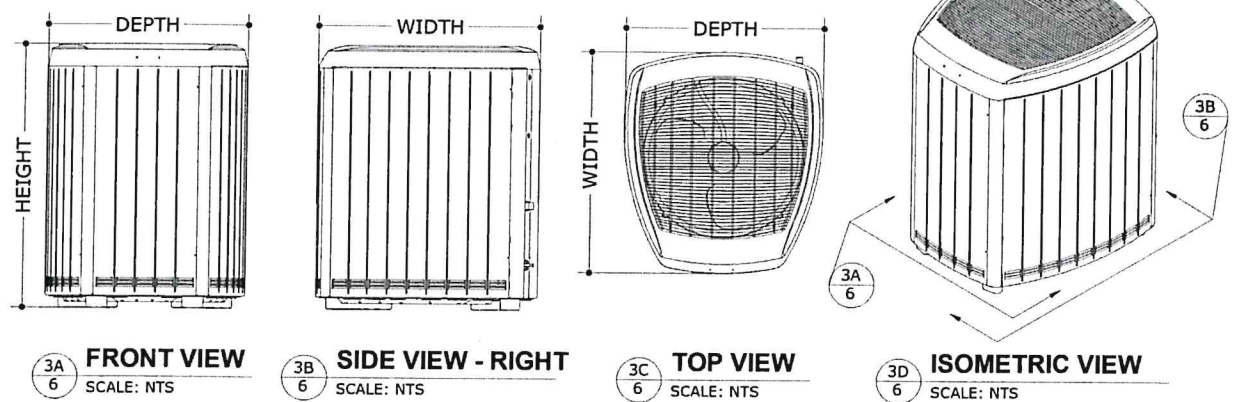

NOTE: Unit depictions in Details 3A through 3D are for illustrative purposes only. Actual units may vary slightly in appearance. Louvers on wall panels are not shown. Louver direction may be horizontal or vertical. This Cabinet Type is applicable for Merit Series - Louver units (see "Model Information" on pages 3 through 5 for model designations).

CABINET TYPES, VIEWS, & DIMENSIONS, CONTINUED

WIRE GUARD UNITS: MERIT SERIES

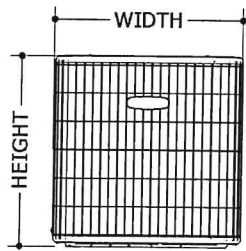

4A
7 **FRONT VIEW**
SCALE: NTS

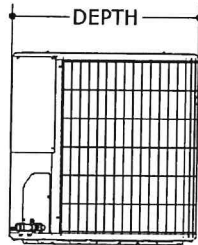

4B
7 **SIDE VIEW - RIGHT**
SCALE: NTS

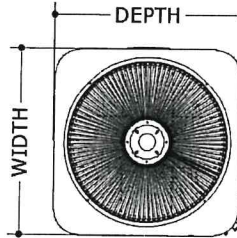

4C
7 **TOP VIEW**
SCALE: NTS

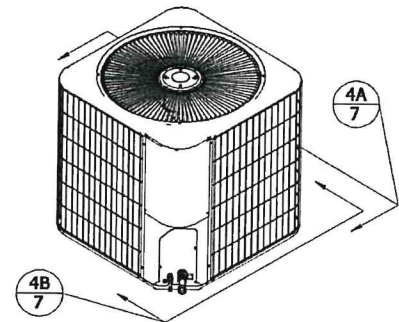

4D
7 **ISOMETRIC VIEW**
SCALE: NTS

NOTE: Unit depictions in Details 4A through 4D are for illustrative purposes only. Actual units may vary slightly in appearance. This Cabinet Type is applicable for Merit Series - Wire Guard units (see "Model Information" on pages 3 through 5 for model designations).

FORCES SUMMARY

Cabinet Type	Wind Pressure Lateral (Uplift)	Long Side (Width x Height)			Short Side (Depth x Height)			Max. Uplift Force
		Max. Sliding Force	Max. Overturning Moment	Max. Tension per Side	Max. Sliding Force	Max. Overturning Moment	Max. Tension per Side	
Louver	± 67 psf (0 psf)	863.8 lb	16828.0 lb-in	630.3 lb	776.3 lb	13108.4 lb-in	331.9 lb	0.0 lb
	± 90 psf (72 psf)	1160.3 lb	33156.4 lb-in	1241.8 lb	1042.8 lb	33218.3 lb-in	841.0 lb	701.1 lb
	± 120 psf (95 psf)	1547.1 lb	45235.5 lb-in	1694.2 lb	1390.4 lb	45810.4 lb-in	1159.8 lb	925.1 lb
	± 148 psf (117 psf)	1908.1 lb	56578.7 lb-in	2119.1 lb	1714.8 lb	57665.6 lb-in	1459.9 lb	1139.3 lb
Wire Guard	± 67 psf (0 psf)	649.0 lb	12421.6 lb-in	385.2 lb	649.0 lb	12421.6 lb-in	385.2 lb	0.0 lb
	± 90 psf (72 psf)	871.8 lb	25624.8 lb-in	794.6 lb	871.8 lb	25624.8 lb-in	794.6 lb	520.0 lb
	± 120 psf (95 psf)	1162.3 lb	34587.4 lb-in	1072.5 lb	1162.3 lb	34587.4 lb-in	1072.5 lb	686.2 lb
	± 148 psf (117 psf)	1433.6 lb	43014.6 lb-in	1333.8 lb	1433.6 lb	43014.6 lb-in	1333.8 lb	845.1 lb

FORCES SUMMARY NOTES:

All panels were assumed to have 0% porosity for Forces Summary calculations. Calculations were performed according to the information provided by the client and manufacturer-listed specifications. See "Model Information" on pages 3 through 5 for approved unit models.

Louver: The louver cabinet type applies to all louver units (See pages 3 through 7 for unit designations). Forces Summary calculations are based on the worst-case louver unit, which was determined by this office to be a (39.5" W x 35.5" D x 47" H) unit with a net weight of 260 lb.

Wire Guard: The wire guard cabinet type applies to all louver units (See pages 3 through 7 for unit designations). Forces Summary calculations are based on the worst-case wire guard unit, which was determined by this office to be a (32.25" W x 32.25" D x 43.25" H) unit with a net weight of 100 lb.

PRODUCT INSTALLATION

TIE-DOWN CLIP SCHEDULE

Cabinet Type	Wind Pressure Lateral (Uplift)	# of Tie-Down Clips Required
Louver	± 67 psf (0 psf)	4
	± 90 psf (72 psf)	8
	± 120 psf (95 psf)	8
	± 148 psf (117 psf)	8
Wire Guard	± 67 psf (0 psf)	8
	± 90 psf (72 psf)	8
	± 120 psf (95 psf)	8
	± 148 psf (117 psf)	8

TIE-DOWN CLIP SCHEDULE NOTES:

Louver Units: For at-grade pressures up to ± 67 psf lateral (0 psf uplift), position (1) tie-down clip per corner of unit, (4) total. For rooftop pressures up to ± 148 psf lateral (117 psf uplift), position (2) tie-down clips per corner of unit, (8) total. See tie-down layouts on the following pages. Tie-down clip shall sit flush on host structure and flush against unit corner post. Fasten tie-down clip to corner post with (4) #10 SS316 self-drilling screws with 0.395" min. OD washers, typ. Utilize any (4) slots that have flush, solid contact with unit corner post, (1) screw per slot, typ. (See Detail 1/8). Ensure all screws fully engage with unit corner posts. Fasten tie-down clips to host structure using (1) anchor per tie-down clip per the "Anchor Schedule to Host Structure" table shown herein.

WARNING: HIGH PRESSURE REFRIGERANT HAZARD
 Exercise caution while installing screws into the unit to avoid piercing refrigerant lines behind unit base / corner posts. Refrigerant fluid is under high pressure.

Wire Guard Units: Position (2) tie-down clips per corner of unit, (8) total (see tie-down installation layout on the following pages). Provide 4" min. spacing between neighboring tie-down clips. Each tie-down clip shall sit flush on host structure and flush against vertical face of unit base (See Detail 2/8). Fasten tie-down clip to base rail with (2) #10 SS316 self-drilling screws with 0.395" min. OD washers, typ. Utilize the (2) slots that make flush contact with vertical face of unit base, (1) screw per slot, typ. (See Detail 2/8). Ensure all screws fully engage with solid sections of unit base (do not position tie-down clips where holes/slots in the base rail interfere with screw connections). Fasten each tie-down clip to host structure using (1) anchor per the "Anchor Schedule to Host Structure" table shown herein.

ANCHOR SCHEDULE TO HOST STRUCTURE

Wind Pressure Lateral (Uplift)	3000 psi min. Concrete	1/8" min. thick Fy = 36 ksi min. Steel	1/8" min. thick 6061-T6 Aluminum
± 67 psf (0 psf)	A	N/A	N/A
± 90 psf (72 psf)	N/A	B	B
± 120 psf (95 psf)	N/A	B	B
± 148 psf (117 psf)	N/A	B	B

ANCHOR SCHEDULE TO HOST STRUCTURE NOTES:

All host structures described in the anchor schedule are by others. Anchors shall be selected per site-specific wind pressures and host structure. Wind pressures up to ± 67 psf lateral (0 psf uplift) and below shall use the anchor specified in the ± 67 psf lateral (0 psf uplift) tier. Site-specific wind pressures that fall in-between pressure tiers shall use the anchor specified by the higher pressure tier.

Anchor Schedule to Host Structure Key:

A: 1/4" Ø DeWalt UltraCon+ or equivalent with 1" min. OD washer, 1.75" embedment, and 3" min. edge distance from any edge of concrete, typ.
B: 1/4" Ø SAE GR. 5 or SS Thru Bolt with 5/8" min. OD washers top and bottom, typ. Provide 1/2" min. edge distance between Thru Bolt and any edge of substrate, typ.
N/A: Not applicable.

MIAMI TECH TIE-DOWN CLIP

1

Miami Tech CUTD 1" wide and 8" tall ASTM A653 galvanized steel, 0.07" min. thick.

Fasten clip to host structure per the "Anchor Schedule to Host Structure" table and notes.

Fasten clip to unit base rail per the "Tie-Down Clip Schedule" table and notes.

Miami Tech Kit #'s:
 LACUTD8KG - At-Grade or Slab Mounts
 LACUTD8KR - Rooftop or Rail Mounts

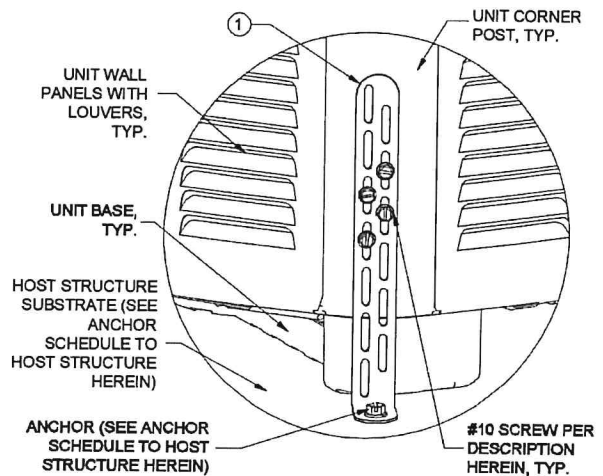
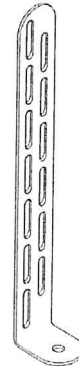

TIE-DOWN CLIP ATTACHMENT TO LOUVER UNITS, TYP.

1
8

SCALE: NTS ISOMETRIC VIEW

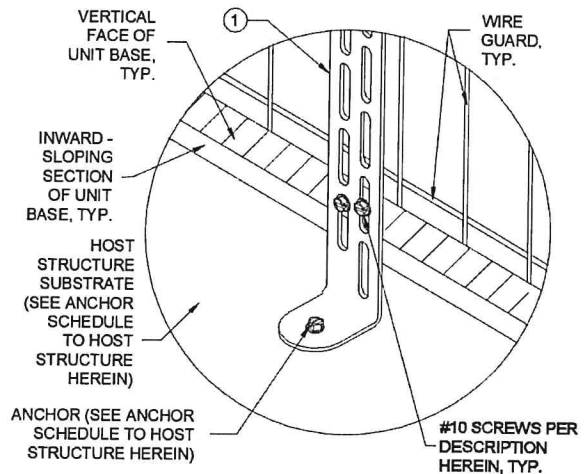

TIE-DOWN CLIP ATTACHMENT TO WIRE GUARD UNITS, TYP.

2
8

SCALE: NTS ISOMETRIC VIEW

PRODUCT INSTALLATION CONTINUED

TIE-DOWN STRAP SCHEDULE

Cabinet Type	Wind Pressure Lateral (Uplift)	# of Straps
Louver	± 67 psf (0 psf)	0
	± 90 psf (72 psf)	2
	± 120 psf (95 psf)	2
	± 148 psf (117 psf)	2
Wire Guard	± 67 psf (0 psf)	0
	± 90 psf (72 psf)	2
	± 120 psf (95 psf)	2
	± 148 psf (117 psf)	2

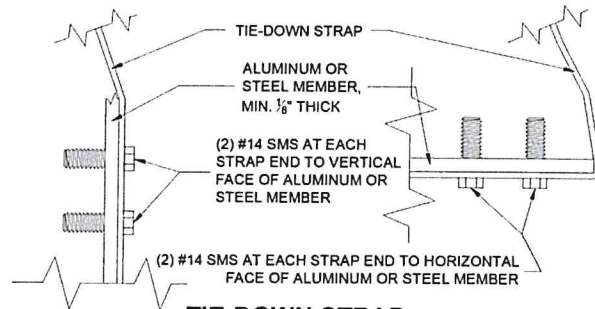

TIE-DOWN STRAP ATTACHMENT TO HOST
 1/9 SCALE: NTS SECTION VIEW

TIE-DOWN STRAP SCHEDULE NOTES:

1. Tie-down straps are required for rooftop applications.
2. Tie-down straps shall be 1" min. wide, 22 GA (0.03") min. thick, Fy = 30 ksi min. galvanized steel straps.
3. Tie-down straps shall be wrapped around unit and roof stand rail per Detail 1/9, and each tie-down strap shall be tightened to 50 lb.
4. (Optional) Neoprene pads may be placed in-between unit and strap to protect the unit from damage.

ROOFTOP INSTALLATION DETAILS

For installation conditions where both:

- i.) The unit in question is adequately supported by the roof stand rails, and
- ii.) The tie-down clip and strap requirements are satisfied using only the roof stand rails,

It is permissible to forgo the roof frame specified herein.

For all other conditions, a roof frame shall be implemented per the specifications herein, or site-specific engineering is required. Support angles per NOA #17-1218.02 are included in Miami Tech Kit #LACUTD8KR.

NOTE: For Detail 3/9, the unit depicted is for illustrative purposes only and may be any of the cabinet types listed herein. Louvers on panels are not shown. See tie-down layouts on the next page.

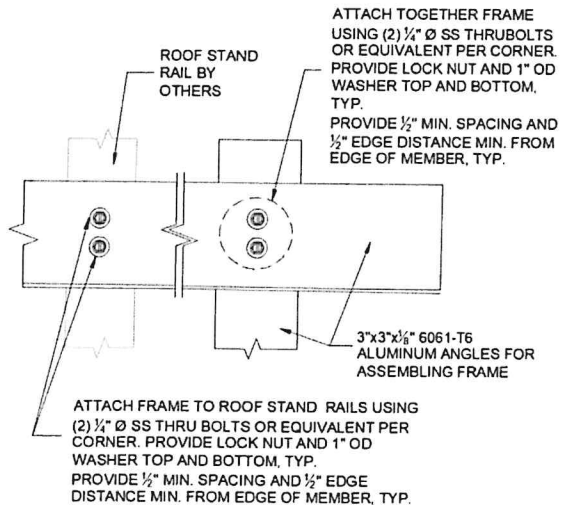

ROOF FRAME TYPICAL CONNECTIONS
 2/9 SCALE: NTS PLAN VIEW

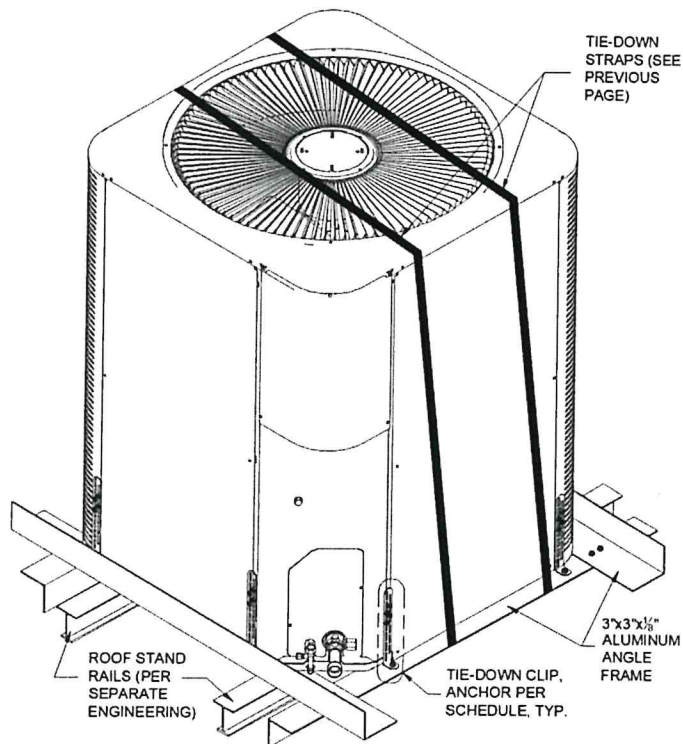

UNIT MOUNT ON ROOF STAND AND FRAME
 3/9 SCALE: NTS ISOMETRIC VIEW

IN ALL CONDITIONS IT IS THE RESPONSIBILITY OF THE PERMIT HOLDER TO ENSURE THE HOST STRUCTURE IS CAPABLE OF WITHSTANDING THE RATED GRAVITY, LATERAL, AND UPLIFT FORCES BY SITE-SPECIFIC DESIGN. NO WARRANTY OF ANY KIND, EXPRESSED OR IMPLIED, IS OFFERED BY ENGINEERING EXPRESS AS TO THE INTEGRITY OF THE HOST STRUCTURE TO CARRY DESIGN FORCE LOADS INCURRED BY THIS UNIT.

TIE-DOWN CLIP & STRAP LAYOUTS

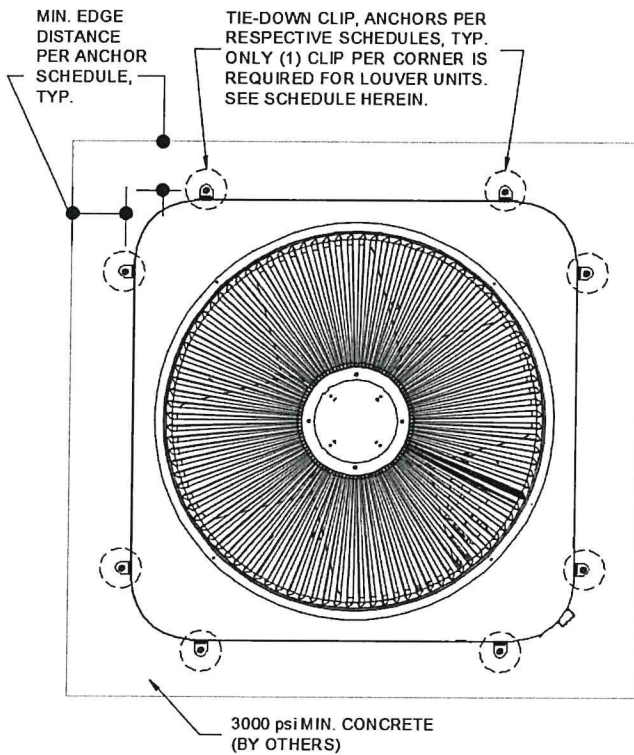

1
10 **AT-GRADE LAYOUT**
SCALE: NTS PLAN VIEW

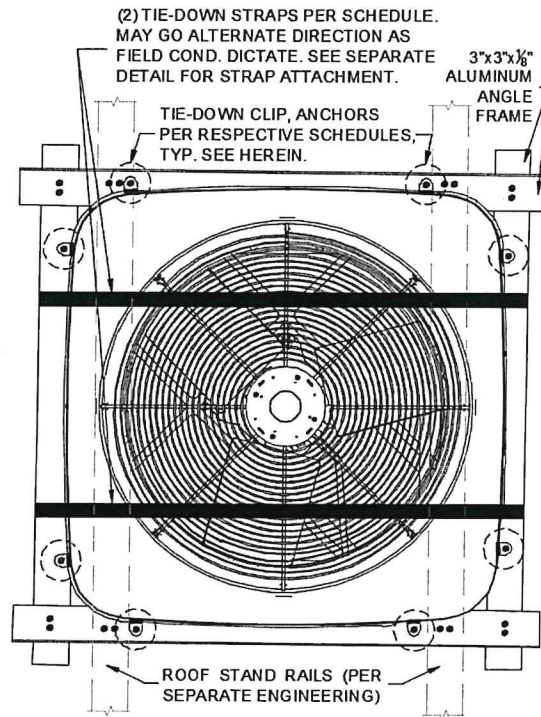

2
10 **ROOFTOP LAYOUT**
SCALE: NTS PLAN VIEW

NOTE: The units depicted on this page are for illustrative purposes only and may be any of the cabinet types listed herein.

NOTE: Units may be positioned on roof stand rails along the unit depth or unit width as long as specifications stated herein are satisfied.

Miami Tech Kit #'s:
LACUTD8KG - At-Grade or Slab Mounts
LACUTD8KR - Rooftop or Rail Mounts

PANEL DESIGNATIONS: LOUVER UNITS, MERIT SERIES

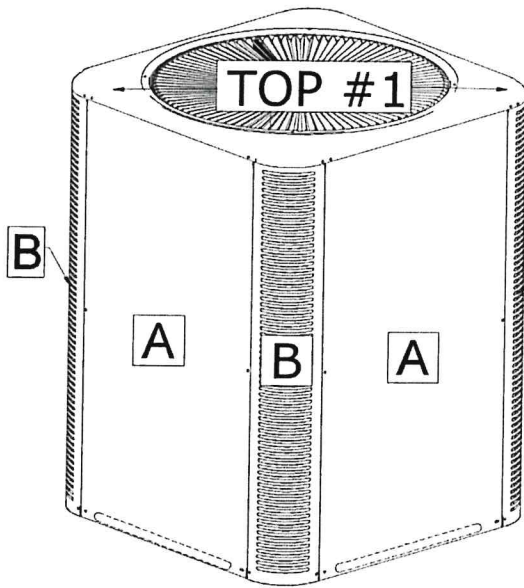

1
11 **FRONT ISOMETRIC VIEW**
SCALE: NTS

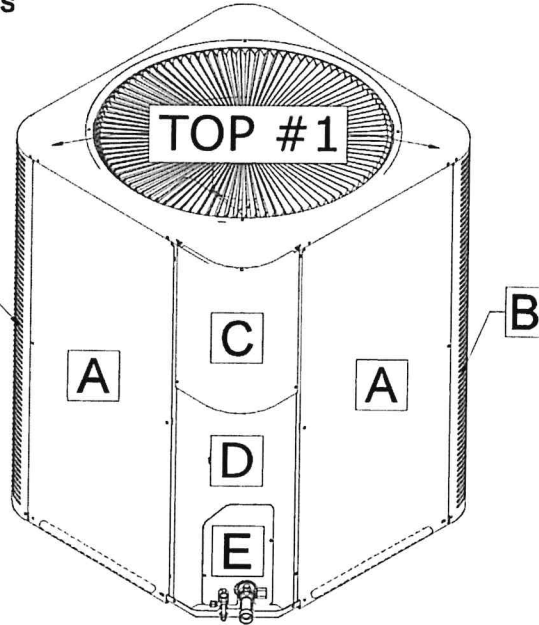

2
11 **BACK ISOMETRIC VIEW**
SCALE: NTS

NOTE: The unit depictions in Details 1/11 and 2/11 are for illustrative purposes only. Actual units may vary slightly in appearance. Louvers on Panel A's (Wall Panels) are not shown. Louver direction may be horizontal or vertical. Circled regions above illustrate additional screw locations per the additional screw directives below. This page applies to Merit Series louver units; see pages 3 through 7 for cabinet type classifications.

PANEL INTEGRITY SUMMARY: LOUVER UNITS, MERIT SERIES

Up to ± 67 psf Lateral & 53 psf Uplift Wind Pressures		
Panel Designation	Additional Screws Required	Additional Screws Directive
Top Panel #1	0	No additional screws required for Top Panel #1.
Panel A (Wall Panel)	0	No additional screws required for Panel A's (Wall Panels).
Panel B (Corner Post)	0	No additional screws required for Panel B's (Corner Posts).
Panel C (Control Box Cover)	0	No additional screws required for Panel C (Control Box Cover).
Panel D	0	No additional screws required for Panel D.
Panel E	0	No additional screws required for Panel E.
NO ADDITIONAL SCREWS REQUIRED		

Up to ± 148 psf Lateral & 117 psf Uplift Wind Pressures		
Panel Designation	Additional Screws Required	Additional Screws Directive
Top Panel #1	0	No additional screws required for Top Panel #1.
Panel A (Wall Panel)	4	Install (4) screws at bottom of each panel into Unit Base. Note: (4) per Panel A, (16) screws total.
Panel B (Corner Post)	0	No additional screws required for Panel B (Corner Posts).
Panel C (Control Box Cover)	0	No additional screws required for Panel C (Control Box Cover).
Panel D	0	No additional screws required for Panel D.
Panel E	0	No additional screws required for Panel E.
(16) ADDITIONAL SCREWS REQUIRED IN TOTAL		

Panel Integrity Summary Notes:

No additional screws are required for wind pressures up to ± 67 psf lateral & 53 psf uplift. Calculations were performed according to the information provided by the client for a worst-case unit (which was determined by this office to be a (39.5" W x 35.5" D x 47" H unit). Panels were assigned various porosities depending on the ratio of louver area to total panel area, for tension and shear calculation purposes. Screw quantities were checked to reinforce unit panels as needed. Additional screws shall be #8 min. diameter SAE GR. 2 or stronger SMS. They shall be positioned according to the "Additional Screws Directives" in the tables above and Details 1/11 and 2/11. Provide 1" min. spacing between neighboring screws (existing or additional). Distribute additional screws evenly between left and right sides of the panel U.N.O.

WARNING: HIGH PRESSURE REFRIGERANT HAZARD
Exercise caution while installing additional screws into the unit to avoid piercing refrigerant lines behind panels. Refrigerant fluid is under high pressure.

Validate that each additional screw joins the panel to the 24 GA min. thick steel member. Screw sizes, quantities on panels, and panel characteristics are according to client's description. 1000 hours of ASTM B117 are required with zero red rust for all additional screws.

PANEL DESIGNATIONS: WIRE GUARD UNITS, MERIT SERIES

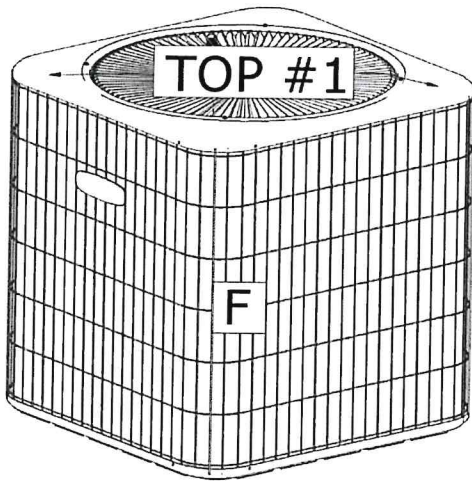

1
12 FRONT ISOMETRIC VIEW
SCALE: NTS

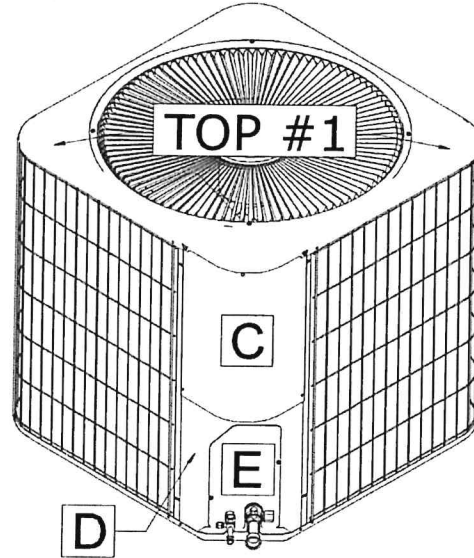

2
12 BACK ISOMETRIC VIEW
SCALE: NTS

NOTE: The unit depictions in Details 1/12 and 2/12 are for illustrative purposes only. Actual units may vary slightly in appearance. This page applies to Merit Series wire guard units; see pages 3 through 7 for cabinet type classifications.

PANEL INTEGRITY SUMMARY: WIRE GUARD UNITS, MERIT SERIES

Up to ± 148 psf Lateral & 117 psf Uplift Wind Pressures		
Panel Designation	Additional Screws Required	Additional Screws Directive
Top Panel #1	0	No additional screws required for Top Panel #1.
Panel C (Control Box Cover)	0	No additional screws required for Panel C (Control Box Cover).
Panel D	0	No additional screws required for Panel D.
Panel E	0	No additional screws required for Panel E.
Panel F (Wire Guard)	N/A	Panel F (Wire Guard) wraps around the four sides of the unit and fastens to the Top Panel and base pan via welding. The weld has been separately examined and deemed to adequately resist the uplift forces acting on the Top Panel.
NO ADDITIONAL SCREWS REQUIRED		

Panel Integrity Summary Notes:

No additional screws are required for wind pressures up to ± 148 psf lateral & 117 psf uplift.

Calculations were performed according to the information provided by the client for a worst-case unit (which was determined by this office to be a (32.25" W x 32.25" D x 43.25" H unit). Panels were assigned various porosities depending on the ratio of louver and/or opening areas to total panel area, for tension and shear calculation purposes. Screw quantities were checked to reinforce unit panels as needed. Weld strength was considered per client-provided specifications.

PANEL DESIGNATIONS: LOUVER UNITS, ELITE SERIES

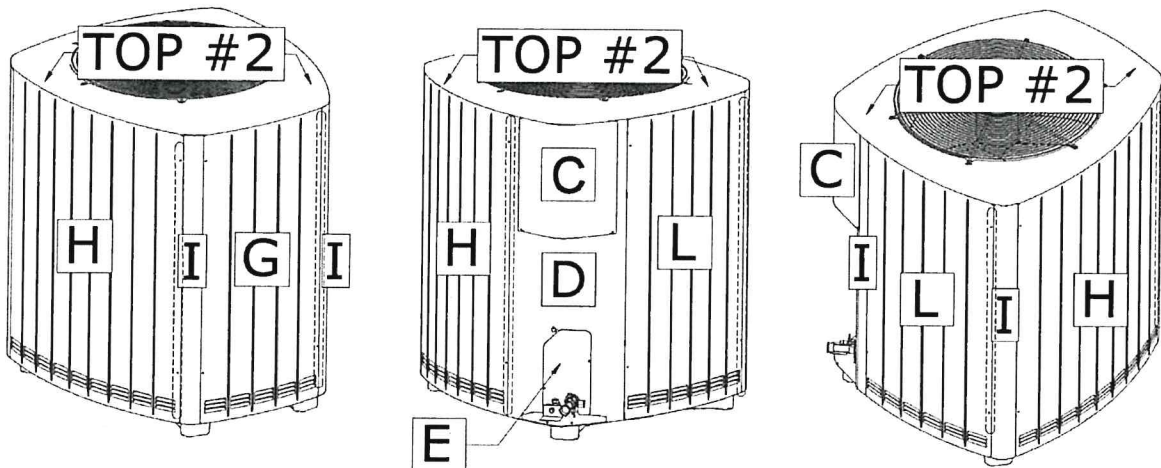

1 FRONT ISOMETRIC VIEW
13 SCALE: NTS

2 BACK ISOMETRIC VIEW #1
13 SCALE: NTS

3 BACK ISOMETRIC VIEW #2
13 SCALE: NTS

NOTE: The unit depictions in Details 1/13 through 3/13 are for illustrative purposes only. Actual units may vary slightly in appearance. Louvers on Panels G, H, & L (Wall Panels) are not shown in full. Louver direction may be horizontal or vertical. Circled regions above illustrate additional screw locations per the additional screw directives below. This page applies to Elite Series louver units; see pages 3 through 7 for cabinet type classifications.

PANEL INTEGRITY SUMMARY: LOUVER UNITS, ELITE SERIES

Up to ± 67 psf Lateral & 53 psf Uplift Wind Pressures		
Panel Designation	Additional Screws Required	Additional Screws Directive
Top Panel #2	0	No additional screws required for Top Panel #2.
Panel C (Control Box Cover)	0	No additional screws required for Panel C (Control Box Cover).
Panel D	0	No additional screws required for Panel D.
Panel E	0	No additional screws required for Panel E.
Panel G (Front Wall Panel)	2	Install (2) screws along the right edge of the Front Wall Panel to join with Panel I (Corner Post).
Panel H (Side Wall Panel)	4	Install (4) screws along the right edge of each Side Wall Panel to join with Panel I's (Corner Posts). Note: (4) per Panel H, (8) total.
Panel I (Corner Post)	0	No additional screws required for Panel I's (Corner Posts).
Panel L (Back Wall Panel)	2	Install (2) screws along the right edge of Side Back Wall Panel to join with Panel I (Corner Post).
(12) ADDITIONAL SCREWS REQUIRED IN TOTAL		

Up to ± 148 psf Lateral & 117 psf Uplift Wind Pressures		
Panel Designation	Additional Screws Required	Additional Screws Directive
Top Panel #2	0	No additional screws required for Top Panel #2.
Panel C (Control Box Cover)	0	No additional screws required for Panel C (Control Box Cover).
Panel D	0	No additional screws required for Panel D.
Panel E	0	No additional screws required for Panel E.
Panel G (Front Wall Panel)	5	Install (5) screws along the right edge of the Front Wall Panel to join with I (non-louvered Corner Post)
Panel H (Side Wall Panel)	8	Install (8) screws along the right edge of each Side Wall Panel to join with Panel I's (Corner Posts). Note: (8) per Panel H, (16) total
Panel I (Corner Post)	0	No additional screws required for Panel I's (Corner Posts).
Panel L (Back Wall Panel)	7	Install (7) screws along the right edge of Side Back Wall Panel to join with Panel I (Corner Post).
(28) ADDITIONAL SCREWS REQUIRED IN TOTAL		

Panel Integrity Summary Notes:

No additional screws are required for wind pressures up to ± 24 psf lateral & 19 psf uplift.

Calculations were performed according to the information provided by the client for a worst-case unit (which was determined by this office to be a (39.5" W x 35.5" D x 47" H unit). Panels were assigned various porosities depending on the ratio of louver area to total panel area, for tension and shear calculation purposes. Screw quantities were checked to reinforce unit panels as needed. Additional screws shall be #8 min. diameter SAE GR. 2 or stronger SMS. They shall be positioned according to the "Additional Screws Directives" in the tables above and Details 1/13 and 2/13. Provide 1" min. spacing between neighboring screws (existing or additional). Distribute additional screws evenly between left and right sides of the panel U.N.O.

WARNING: HIGH PRESSURE REFRIGERANT HAZARD
Exercise caution while installing additional screws into the unit to avoid piercing refrigerant lines behind panels. Refrigerant fluid is under high pressure.

Validate that each additional screw joins the panel to the 24 GA min. thick steel member. Screw sizes, quantities on panels, and panel characteristics are according to client's description. 1000 hours of ASTM B117 are required with zero red rust for all additional screws.

PANEL DESIGNATIONS: LOUVER UNITS, DAVE LENNOX SIGNATURE COLLECTION

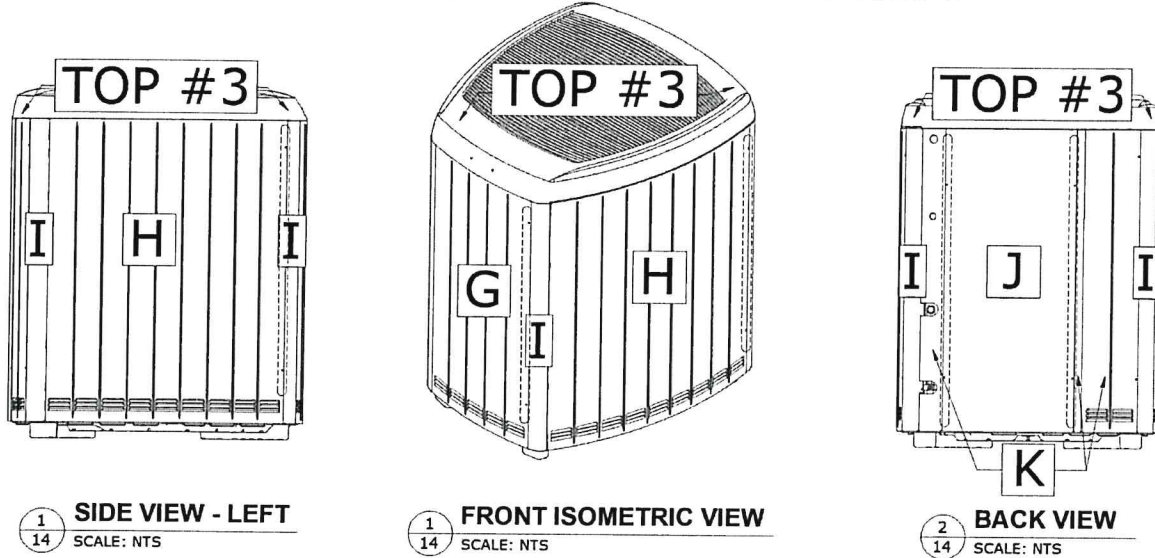

1
14 SIDE VIEW - LEFT
SCALE: NTS

1
14 FRONT ISOMETRIC VIEW
SCALE: NTS

2
14 BACK VIEW
SCALE: NTS

NOTE: The unit depictions in Details 1/13 through 3/13 are for illustrative purposes only. Actual units may vary slightly in appearance. Louvers on Panels G, H, & K (Wall Panels) are not shown in full. Louver direction may be horizontal or vertical. Circled regions above illustrate additional screw locations per the additional screw directives below. This page applies to Dave Lennox Signature Collection louver units; see pages 3 through 7 for cabinet type classifications.

PANEL INTEGRITY SUMMARY: LOUVER UNITS, DAVE LENNOX SIGNATURE COLLECTION

Up to ± 67 psf Lateral & 53 psf Uplift Wind Pressures		
Panel Designation	Additional Screws Required	Additional Screws Directive
Top Panel #3	0	No additional screws required for Top Panel #3.
Panel G (Front Wall Panel)	2	Install (2) screws along the right edge of the Front Wall Panel to join with Panel I (Corner Post).
Panel H (Side Wall Panel)	4	Install (4) screws along the right edge of each Side Wall Panel to join with Panel I's (Corner Posts). Note: (4) per Panel H, (8) total.
Panel I (Corner Post)	0	No additional screws required for Panel I's (Corner Posts).
Panel J (Back Access Panel)	2	Install (2) screws along bottom left and right edges of Panel J. Equally distribute screws between left and right sides.
Panel K (Smaller Back Panels)	0	No additional screws required for Panel K's (smaller back panels).
(12) ADDITIONAL SCREWS REQUIRED IN TOTAL		

Up to ± 148 psf Lateral & 117 psf Uplift Wind Pressures		
Panel Designation	Additional Screws Required	Additional Screws Directive
Top Panel #3	0	No additional screws required for Top Panel #3.
Panel G (Front Wall Panel)	5	Install (5) screws along the right edge of the Front Wall Panel to join with Panel I (Corner Post).
Panel H (Side Wall Panel)	8	Install (8) screws along the right edge of each Side Wall Panel to join with Panel I's (Corner Posts). Note: (8) per Panel H, (16) total.
Panel I (Corner Post)	0	No additional screws required for Panel I's (Corner Posts).
Panel J (Back Access Panel)	12	Install (8) screws along bottom left and right edges of Panel J. Install (4) screws along top left and right edges of Panel J. Equally distribute screws between left and right sides.
Panel K (Smaller Back Panels)	0	No additional screws required for Panel K's (smaller back panels).
(33) ADDITIONAL SCREWS REQUIRED IN TOTAL		

Panel Integrity Summary Notes:

No additional screws are required for wind pressures up to ± 24 psf lateral & 19 psf uplift. Calculations were performed according to the information provided by the client for a worst-case unit (which was determined by this office to be a (39.5" W x 35.5" D x 47" H unit). Panels were assigned various porosities depending on the ratio of louver area to total panel area, for tension and shear calculation purposes. Screw quantities were checked to reinforce unit panels as needed. Additional screws shall be #8 min. diameter SAE GR. 2 or stronger SMS. They shall be positioned according to the "Additional Screws Directives" in the tables above and Details 1/13 and 2/13. Provide 1" min. spacing between neighboring screws (existing or additional). Distribute additional screws evenly between left and right sides of the panel U.N.O.

WARNING: HIGH PRESSURE REFRIGERANT HAZARD
Exercise caution while installing additional screws into the unit to avoid piercing refrigerant lines behind panels. Refrigerant fluid is under high pressure.

Validate that each additional screw joins the panel to the 24 GA min. thick steel member. Screw sizes, quantities on panels, and panel characteristics are according to client's description. 1000 hours of ASTM B117 are required with zero red rust for all additional screws.

TERMINOLOGY (CONTINUED):

The following abbreviations may appear in this report: "ASCE" for "American Society of Civil Engineers", "ASD" for "Allowable Stress Design", "FBC" for "Florida Building Code", "FLCA" for "Florida Certificate of Authorization", "FMC" for "Florida Mechanical Code", "HVAC" for "heating, ventilation, and air conditioning", "in" for "inch", "lb" for "pound (force)", "max." for "maximum", "min." for "minimum", "NTS" for "not to scale", "OD" for "outer diameter", "PE" for "Professional Engineer", "SAE" for "Society of Automotive Engineering", "SECB" for "Structural Engineering Certification Board", "SMS" for "sheet metal screws", "SS" for "stainless steel", "TER" for "Technical Evaluation Report", "typ." for "typical", "U.N.O." for "unless noted otherwise", "w/o" for "without", "#" for "number", and "Ø" for "diameter". For additional abbreviation/terminology clarifications, please contact this office.

LIMITATIONS & CONDITIONS OF USE (CONTINUED):

Use of this product shall be in strict accordance with this TER as noted herein. The supporting host structure shall be designed to resist all superimposed loads as determined by others on a site-specific basis as may be required by the authority having jurisdiction. Host structure conditions which are not accounted for in this product's respective anchor schedule shall be designed for on a site-specific basis by a registered Professional Engineer. No evaluation is offered for the host supporting structure by use of this document. Adjustment factors noted herein and the applicable building codes must be considered, where applicable. All supporting components which are permanently installed shall be protected against corrosion, contamination, and other such damage at all times. Fasteners must penetrate the supporting members such that the full length of the threaded portion is embedded within the main member. This evaluation does not offer any evaluation to meet large missile impact debris requirements under any circumstance.

All of the wind resisting exterior panels individually meet or exceed their capacity to resist the design wind loads as stated in the calculations as required by the FBC. Due to the indeterminate nature of these units, distortion and deflection cannot be accurately evaluated, but with diaphragm action of external components and internal stiffeners, the base unit has the capacity to withstand these forces with individual external parts being contained. Inspections shall be implemented during annual equipment maintenance or after a named storm; all fasteners and cabinet components are to be verified, and all damaged, loose, corroded and/or broken fasteners and cabinet components shall be replaced to ensure structural integrity against hurricane wind forces. Contact this office for any reevaluation needs as designated by the Authority Having Jurisdiction.

Remarks	Drawn	Checked	Date
Initial Issue (20-29015 Master Project)	EPR	RWN	10/30/20