

THIS DOCUMENT CONTAINS (8) PAGES.
ENGINEER DIGITAL OR ORIGINAL HAND SEAL REQUIRED FOR USE.
COPIES ARE NOT VALID FOR PERMIT.

(Subject to Renew January 1, 2025 or next code cycle)

EVALUATION SUBJECT: **DAIKIN SPLIT SYSTEMS**

TER-20-34272

REPORT HOLDER:

DAIKIN COMFORT TECHNOLOGIES MANUFACTURING, L.P.
19001 KERMIER ROAD
WALLER, TX 77484, USA
877-254-4729 | DAIKINCOMFORT.COM



SCOPE OF EVALUATION (compliance with the following codes):

THIS IS A STRUCTURAL (WIND) PERFORMANCE EVALUATION ONLY. NO ELECTRICAL OR TEMPERATURE PERFORMANCE RATINGS OR CERTIFICATIONS ARE OFFERED OR IMPLIED HEREIN. UNDER NO CIRCUMSTANCE DOES THIS PERFORMANCE EVALUATION GUARANTEE, IMPLY, OR STATE PERFORMANCE OF THE UNIT IS MAINTAINED DURING OR AFTER A DESIGN EVENT.

This Product Evaluation Report is being issued in accordance with the requirements of the **Florida Building Code Seventh Edition (2020)** per ASCE 7, FBC Building Ch. 16, FBC Building Sections 104.11 & 1522.2, FBC Existing Building Sections 707.1 & 707.2, FBC Mechanical 301.15, FBC Residential M1202.1 & M1301.1, FS 471.025, and Broward County Administrative Provisions 107.3.4. This report is also in accordance with the **International Building & Residential Codes (2012, 2015, & 2018)**. The product noted on this report has been tested and/or evaluated as summarized herein.

IN ACCORDANCE WITH THESE CODES EACH OF THESE REPORTS MUST BEAR THE ORIGINAL SIGNATURE & RAISED SEAL OR DIGITAL SEAL OF THE EVALUATING ENGINEER.

SUBSTANTIATING DATA:

• Product Evaluation Documents

Substantiating documentation has been submitted to provide this TER and is summarized in the sections below.

• Structural Engineering Calculations

Structural engineering calculations have been prepared which evaluate the product based on comparative and/or rational analysis to qualify the following design criteria:

- Max. allowable lateral & uplift wind pressures certified herein
- Max. allowable sliding forces, uplift forces, & overturning moments (see Unit Reactions from Wind Guide on last page)
- Tie-down configuration and anchor capacity for concrete, aluminum, and steel host substrates (host by others).
- Unit panel wind pressure connection integrity

Calculation summary is included in this TER and appears herein. NOTE: No 33% increase in allowable stress has been used in the design of this product.

LIMITATIONS & CONDITIONS OF USE:

Use of the product(s) listed herein shall be in strict accordance with this TER as noted herein and manufacturer-provided model specifications. Installation shall conform to the minimum standards stated in the referenced building code(s) in addition to the specifications and limitations stated herein. See herein for complete limitations & conditions of use.

OPTIONS:

This evaluation is valid for the DAIKIN models described herein. The critical unit designs have been determined and used in this evaluation. Any structural changes outside of the design as described herein would void this certification.

UNIT CASING MATERIALS:

26ga galvanized sheet steel ASTM A653 CS cold rolled steels for side covers.
22ga galvanized sheet steel ASTM A653 cold rolled steel for bottom base pan.
20ga galvanized sheet steel ASTM A653 cold rolled steel for top panel.
Removable top & side covers secured with #10-12 sheet metal screws.
Knockouts provided for utility & control connections. Contact Report Holder for further unit construction information.

NOTE: THE GRAPHICAL DEPICTIONS IN THIS REPORT ARE FOR ILLUSTRATIVE PURPOSES ONLY AND MAY DIFFER IN APPEARANCE.

STRUCTURAL PERFORMANCE:

Models referenced herein are subject to the following design limitations:

Maximum Rated Wind Pressures*:
± 119 psf Lateral, 94 psf Uplift

- Required design wind pressures shall be determined according to the guide provided in the Appendix (see last page of this report) or on a site-specific basis in accordance with ASCE 7 and applicable sections of the building code(s) being referenced in accordance with ASD methodology.
- Required design pressures shall be less than or equal to the maximum pressures listed herein.
- *Maximum Rated Wind Pressures indicate the maximum pressures that all units listed herein are approved for. Valid for at-grade and rooftop applications. See limitations herein.
- Valid for use inside and outside the High-Velocity Hurricane Zone (HVHZ).
- Site-specific wind analysis may produce alternate limitations provided maximum rated wind pressures stated herein are not exceeded.

VISIT [ECALC.IO/DAIKIN](https://ecalculator.com/daikin)

FOR ENGINEER CERTIFIED ORIGINALS & MORE INFORMATION ABOUT THIS DOCUMENT OR SCAN THE QR CODE TO THE RIGHT >

VISIT [ENGINEERINGEXPRESS.COM/STORE](https://engineeringexpress.com/store) FOR ADDITIONAL PLANS, REPORTS & RESOURCES



ORIGINAL SIGNATURE AND RAISED SEAL
OR DIGITAL SEAL REQUIRED TO BE VALID PER CODE:



**VALID ONLY FOR ZIP CODE: 00000
VALID ONLY FOR MANUFACTURER'S RECORDS ONLY
NOT VALID FOR PERMIT OR CONSTRUCTION USE
PE0046549 CA-9885**

DIGITAL SEAL NOTICE: IF THIS DOCUMENT IS DIGITALLY SIGNED, THIS SHEET IS PART OF A DIGITALLY SIGNED FILE. IT SHALL REMAIN IN DIGITAL FORMAT, SHALL BE VERIFIED BY ELECTRONIC MEANS, & PRINTED COPIES OF THIS DOCUMENT ARE NOT CONSIDERED SIGNED AND SEALED. VISIT [ECALC.IO/DS](https://ecalculator.com/ds) FOR MORE INFORMATION.

PRINTED DOCUMENT NOTICE: IF THIS DOCUMENT IS PRINTED & DOES NOT CONTAIN AN ENGINEER'S ORIGINAL SIGNATURE & SEAL, THIS DOCUMENT IS VOID & NOT VALID FOR USE. PHOTOCOPIES ARE NOT PERMITTED FOR USE.

MODEL INFORMATION (CONTINUED ON NEXT PAGE)

Cabinet Group	Model Number	Unit Dimensions (in)		
		Width	Depth	Height
A1	DX13S(A,N)0181	23	23	25.75
B1	DX13S(A,N)0241	26	26	27.5
B1	DX13S(A,N)0301	26	26	27.5
B1	DX13S(A,N)0361	26	26	27.5
C3	DX13S(A,N)0421	29	29	36.25
C3	DX13S(A,N)0481	29	29	36.25
C6	DX13S(A,N)0601	29	29	40
D5	DX13S(A,N)0611	35.5	35.5	38.25
D2	DX13SA0363A*	29	29	28.75
C2	DX13SA0364A*	29	29	28.75
C5	DX13SA0483A*	29	29	36.25
C5	DX13SA0484A*	29	29	36.25
D3	DX13SA0603A*	35.5	35.5	38.25
D3	DX13SA0604A*	35.5	35.5	38.25
B1	DX14S(A,N)0181	26	26	27.5
B1	DX14S(A,N)0191	26	26	27.5
B1	DX14S(A,N)0241	26	26	27.5
B2	DX14S(A,N)0251	26	26	32.5
C2	DX14S(A,N)0301	29	29	32.5
C2	DX14S(A,N)0311	29	29	32.5
C2	DX14S(A,N)0361	29	29	32.5
C2	DX14S(A,N)0371	29	29	32.5
C3	DX14S(A,N)0421	29	29	36.25
C3	DX14S(A,N)0431	29	29	36.25
D1	DX14S(A,N)0481	35.5	35.5	36.25
D5	DX14S(A,N)0601	35.5	35.5	38.25
C2	DX16SA0181	29	29	32.25
C2	DX16SA0241	29	29	32.25
C3	DX16SA0301	29	29	36.25
C3	DX16SA0311A	29	29	38.25
C6	DX16SA0361	29	29	38.25
D1	DX16SA0371A	35.5	35.5	36.25
D1	DX16SA0421	35.5	35.5	36.25
D5	DX16SA0481	35.5	35.5	36.25
D3	DX16SA0601	35.5	35.5	38.25
D5	DX16SA0611	35.5	35.5	38.25
C2	DX16TC0241	29.25	29.25	32.25
D3	DX16TC0361	35.75	35.75	36.5
D3	DX16TC0481	35.75	35.75	37

Cabinet Group	Model Number	Unit Dimensions (in)		
		Width	Depth	Height
D6	DX16TC0601	35.75	35.75	42.25
D6	DX18TC0241	35.75	35.75	40
D6	DX18TC0361	35.75	35.75	40
D6	DX18TC0481	35.75	35.75	42.25
D6	DX18TC0601	35.75	35.75	42.25
D4	DX20VC0241	35.5	35.5	38.25
D4	DX20VC0361	35.5	35.5	38.25
D6	DX20VC0481	35.5	35.5	41.75
D6	DX20VC0601	35.5	35.5	41.75
C2	DX3SEA3630**	29	29	32.5
C2	DX3SEA3640**	29	29	32.5
D1	DX3SEA4830**	35.5	35.5	35.75
D1	DX3SEA4840**	35.5	35.5	35.75
D6	DX3SEA6030**	35.5	35.5	39.5
D6	DX3SEA6040**	35.5	35.5	39.5
B1	DX4SEA1810	26	26	27
C2	DX4SEA2410	29	29	32
D6	DX4SEA3010	35½	35½	39½
D6	DX4SEA3610	35½	35½	39½
D1	DX4SEA4210	35½	35½	36½
D1	DX4SEA4810	35½	35½	36½
D6	DX4SEA6010	35½	35½	41½
B1	DX4SQA1810	26	26	27
B2	DX4SQA2410	26	26	32½
C4	DX4SQA3010	29	29	39½
D1	DX4SQA3610	35½	35½	35¾
D6	DX4SQA4210	35½	35½	39½
D6	DX4SQA4810	35½	35½	39½
D1	DX4SQA6010	35½	35½	36½
B1	DX5SEA1810	26	26	27
C2	DX5SEA2410	29	29	32
D6	DX5SEA3010	35½	35½	39½
D6	DX5SEA3610	35½	35½	39½
D1	DX5SEA4210	35½	35½	36½
D1	DX5SEA4810	35½	35½	36½
D6	DX5SEA6010	35½	35½	41½
D6	DX7TCA2410	35½	35½	39½
D6	DX7TCA3610	35½	35½	39½
D6	DX7TCA4810	35½	35½	41½

Note: The model numbers on this page may be followed by up to two (2) alphanumeric characters. Those characters will not affect the structural performance, since they refer to minor/major changes not related to the cabinet structure.

MODEL INFORMATION (CONTINUED FROM PREVIOUS PAGE)

Cabinet Group	Model Number	Unit Dimensions (in)		
		Width	Depth	Height
D6	DX7TCA6010	35½	35½	41%
D4	DX9VCA2410	35.5	35.5	35
D4	DX9VCA3610	35.5	35.5	35
D6	DX9VCA4810	35.5	35.5	42.25
D6	DX9VCA6010	35.5	35.5	42.25
C2	DZ13SA0363A*	29	29	32.25
C1	DZ13SA0483A*	29	29	34.25
C1	DZ13SA0484A*	29	29	34.25
C2	DZ13SA0603A*	35.5	35.5	34.25
D2	DZ13SA0604A*	35.5	35.5	34.25
C1	DZ14S(A,N)0181	29	29	34.5
C1	DZ14S(A,N)0241	29	29	34.5
C5	DZ14S(A,N)0301	29	29	36.25
C5	DZ14S(A,N)0361	29	29	36.25
D6	DZ14S(A,N)0421	35.5	35.5	39.75
C5	DZ14S(A,N)0481	29	29	36.25
D2	DZ14S(A,N)0491	35.5	35.5	34.5
D2	DZ14S(A,N)0601	35.5	35.5	34.5
C1	DZ14S(A,N)14019	29	29	34.5
C1	DZ14S(A,N)14025	29	29	34.5
D2	DZ14S(A,N)14031	35.5	35.5	34.63
D6	DZ14S(A,N)14037	35.5	35.5	40
C2	DZ14SA0363A*	29	29	32.25
C2	DZ14SA0364A*	29	29	32.25
C1	DZ14SA0483A*	29	29	34.25
C1	DZ14SA0484A*	29	29	34.25
D2	DZ14SA0603A*	35.5	35.5	34.25
D2	DZ14SA0604A*	35.5	35.5	34.25
C5	DZ16SA0181	29	29	36.38
D2	DZ16SA0241	35.5	35.5	34.63
D2	DZ16SA0301	35.5	35.5	34.63
D6	DZ16SA0361	35.5	35.5	40
C5	DZ16SA0421	29	29	36.38
D2	DZ16SA0481	35.5	35.5	34.63
D6	DZ16SA0601	35.5	35.5	40
C4	DZ16TC0241	29	29	38.25
D2	DZ16TC0241C	35.5	35.5	34.63
D3	DZ16TC0361	35.5	35.5	38.25
D6	DZ16TC0361C	35.5	35.5	40
D3	DZ16TC0481	35.5	35.5	38.25
D2	DZ16TC0481C	35.5	35.5	34.63
D3	DZ16TC0601	35.5	35.5	38.25
D6	DZ16TC0601C	35.5	35.5	40
D6	DZ18TC0241C	35.5	35.5	40
D3	DZ18TC0361	35.5	35.5	38.25
D2	DZ18TC0361C	35.5	35.5	34.63
D3	DZ18TC0481	35.5	35.5	38.25

Cabinet Group	Model Number	Unit Dimensions (in)		
		Width	Depth	Height
D6	DZ18TC0481C	35.5	35.5	40
D3	DZ18TC0601	35.5	35.5	38.25
D6	DZ18TC0601C	35.5	35.5	40
C5	DZ18VC0241	29	29	38.25
C5	DZ18VC0361	29	29	38.25
D2	DZ18VC0481	35.5	35.5	38.25
D2	DZ18VC0601	35.5	35.5	38.25
D4	DZ20VC0241	35.5	35.5	38.25
D6	DZ20VC0361	35.5	35.5	41.25
D6	DZ20VC0481	35.5	35.5	41.25
D6	DZ20VC0601	35.5	35.5	41.25
C3	DZ4SEA1810	29	29	35.75
C3	DZ4SEA2410	29	29	35.75
C4	DZ4SEA3010	29	29	39.5
D6	DZ4SEA3610	35.5	35.5	39.5
D6	DZ4SEA3630**	35.5	35.5	39.5
D6	DZ4SEA3640**	35.5	35.5	39.5
D1	DZ4SEA4210	35.5	35.5	35.75
D1	DZ4SEA4810	35.5	35.5	36.5
D1	DZ4SEA4810	35.5	35.5	36.5
D1	DZ4SEA4830**	35.5	35.5	36.5
D1	DZ4SEA4840**	35.5	35.5	36.5
D6	DZ4SEA6010	35.5	35.5	41.63
D6	DZ4SEA6030**	35.5	35.5	41.63
D6	DZ4SEA6040**	35.5	35.5	41.63
C3	DZ4SQA1810	29	29	35.75
C3	DZ4SQA2410	29	29	35.75
C4	DZ4SQA3010	29	29	39.5
D6	DZ4SQA3610	35.5	35.5	39.5
D1	DZ4SQA4210	35.5	35.5	35.75
D1	DZ4SQA4810	35.5	35.5	36.58
D6	DZ4SQA6010	35.5	35.5	41.63
D6	DZ5SEA1810	29	29	39½
D1	DZ5SEA2410	35½	35½	35¾
D6	DZ5SEA3010	35½	35½	39½
D6	DZ5SEA3610	35½	35½	39½
D1	DZ5SEA4210	35½	35½	35¾
D1	DZ5SEA4810	35½	35½	36½
D6	DZ5SEA6010	35½	35½	41%
D6	DZ7TCA2410	35.5	35.5	39.5
D1	DZ7TCA3610	35.5	35.5	35.75
D6	DZ7TCA4810	35.5	35.5	41.63
D6	DZ7TCA6010	35.5	35.5	41.63
D4	DZ9VCA2410	35.5	35.5	35
D6	DZ9VCA3610	35.5	35.5	42.25
D6	DZ9VCA4810	35.5	35.5	42.25
D6	DZ9VCA6010	35.5	35.5	42.25

Note: The model numbers on this page may be followed by up to two (2) alphanumeric characters. Those characters will not affect the structural performance, since they refer to minor/major changes not related to the cabinet structure.

MODEL INFORMATION NOTES

Unit dimensions listed above are unit net dimensions (as opposed to packing/shipping dimensions). Unit net weights shall be between 120 lb and 400 lb, typ. Model information listed herein is based on information provided by the client. See Detail below for definitions of unit dimensions. Unit appearance may vary. Please contact Report Holder for more information.

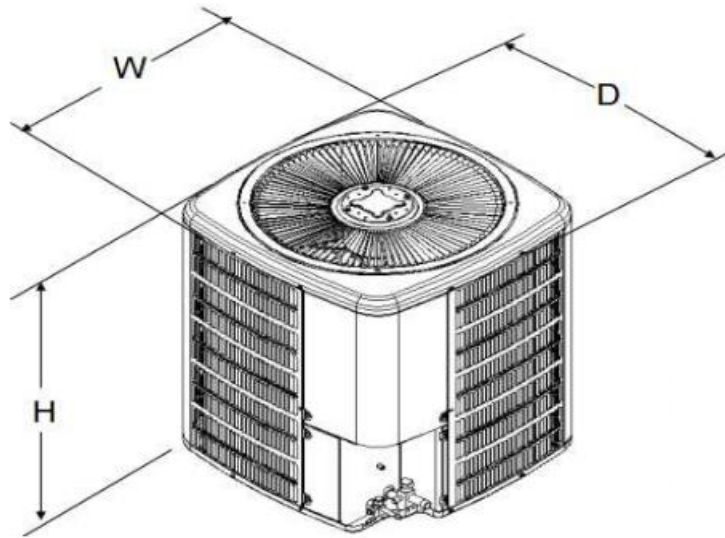

REMAINDER OF PAGE INTENTIONALLY LEFT BLANK

PRODUCT INSTALLATION

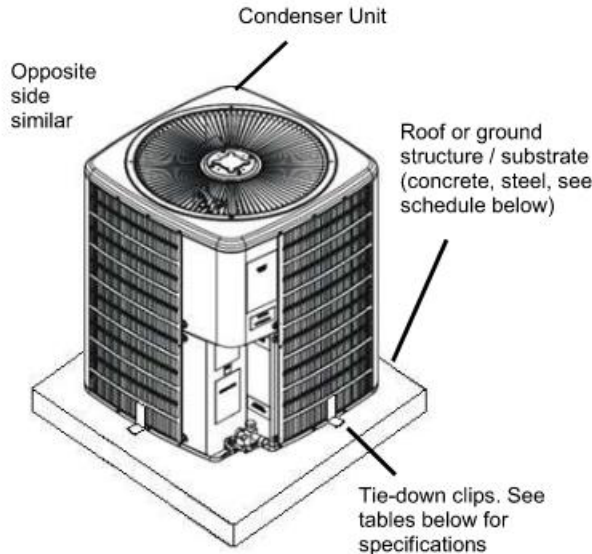

TIE-DOWN CLIP (GROUND APPLICATION)

ASTM A653 G60 galvanized cold rolled steel 0.072" thick for all cabinets tied down at ground (Goodman Bracket); fasten cabinet using (2) anchors per clip from Anchor to Host Structure Schedule Table. Clip integrates into base pan slot.

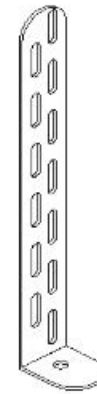

TIE-DOWN CLIP (GROUND AND ROOF APPLICATION)

Miami Tech CUTD 1" wide and any length ASTM A653 galvanized steel 0.07" thick for all cabinets tied down to a roof structure; fasten clip to structure using anchor from Anchor Schedule to Host Structure Table and (2) #10 x 1/2" SS 410 self-drilling screw to fasten clip to unit base pan. See Tie-down Strap & Clip Schedule Table for clip amount. Hurricane kit #DGACUTD36K

Tie-Down Strap & Clip Schedule						
Unit Model	Max Lateral Pressure	Max Uplift Pressure	Strap Req'd?	Qty	Minimum WLL (lbs)	Tie Down Clips Needed
Cabinet A1	50 psf	39 psf	NO	N/A	N/A	4
	106 psf	84 psf	YES	2	300	8
	119 psf	94 psf	YES	2	400	8
Cabinet B1, B2	50 psf	39 psf	NO	N/A	N/A	4
	106 psf	84 psf	YES	2	400	8
	119 psf	94 psf	YES	2	400	8
Cabinet C1 to C6	50 psf	39 psf	NO	N/A	N/A	4
	106 psf	84 psf	YES	2	500	8
	119 psf	94 psf	YES	2	600	8
Cabinet D1 to D6	50 psf	39 psf	NO	N/A	N/A	4
	106 psf	84 psf	YES	2	600	8
	119 psf	94 psf	YES	2	600	8

Anchor to Host Structure Schedule					
Unit Model	Max Lateral Pressure	Max Uplift Pressure	Concrete 3,000 psi	1/8" Min A36 Steel	1/8" Min 6061-T6 Aluminum
All Cabinets A1, B1-2, C1-6, D1-6	50 psf	39 psf	A	N/A	N/A
	119 psf	94 psf	N/A	B	B

Panel Integrity Summary			
Unit Model	Max Lateral Pressure	Max Uplift Pressure	Horizontal Strapping Required
All Cabinets A1, B1-2, C1-5, D1-6	50 psf	39 psf	NONE
	119 psf	94 psf	NONE

Tie-down Strap & Clip Type: (for roof applications)

Working Load Limit (WLL) is strap's manufacturer - specified per strap. A minimum strap width of 1" is required for all cabinets.

Clips heights shall be adequate to fit SMS within base pan height. Verify height on site.

Clips should be placed at center on each side and equally spaced, for ground mounted condition. See details in page 3, for roof mounted condition.

Note: (Vertical Strapping)

1. Tie-down straps shall be wrapped around unit and roof stand rail, and shall be tightened using the buckle. Provide two straps per unit.
2. Strap material shall be either high strength webbing and shall be compliant for exterior grade use if they contain plastic components, per FBC chapter 26. Or 1" wide 22ga ASTM A653 steel strap secured with (2) #14 SS sms to the bottom of the stand rail.
3. For 200 MPH Non-HVHZ, use (2) metal straps, up to 56' MRH Exposure C.

Anchor Types to Host Structure:

- A. - 1/4" Dewalt ULTRACON SS4 Anchor embedded 3" in 3,000 psi concrete. 2 1/2" from edge minimum.
- B. - 1/4" -20 UNC SS 316 bolt min. 1/2" from edges with nut and 1" OD washer
- NA. - No anchors apply.

STRAP AND CLIP LAYOUT ROOF INSTALLATIONS

NOTES:

1. 3"x2"x1/8" ALUMINUM ANGLE SHALL BE 6061-T6 AND SHALL OVERHANG 8" MAXIMUM FROM STAND RAIL PER SIDE.
2. CONDENSER SHALL REST ON TOP OF THE STAND RAILS.
3. CLIPS MAY NOT COINCIDE WITH RAIL BELOW, ATTACHED ANGLE USING (2) 1/4" THROBOLT W/ NUT AND 1.0 OD WASHER.
4. TIE-DOWN CLIPS FOR CABINETS EQUAL OR SMALLER THAN 26" WIDE SHALL BE LOCATED 1" FROM EDGE MIN.

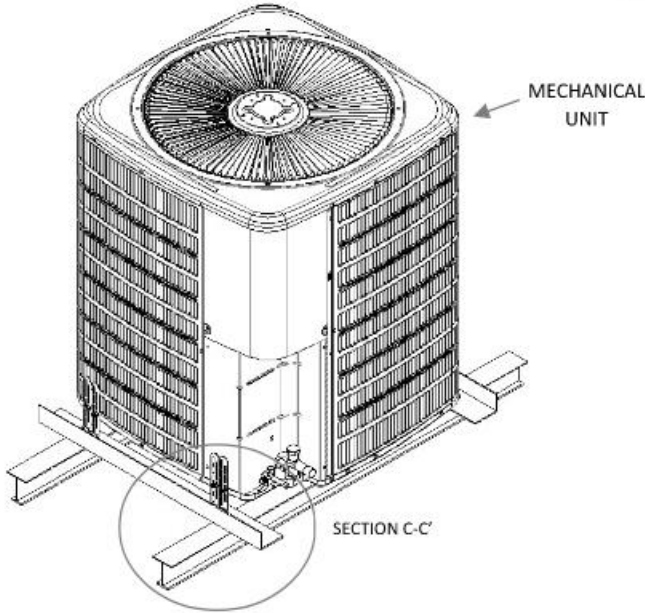

MECHANICAL UNIT ROOF MOUNTED ISOMETRIC

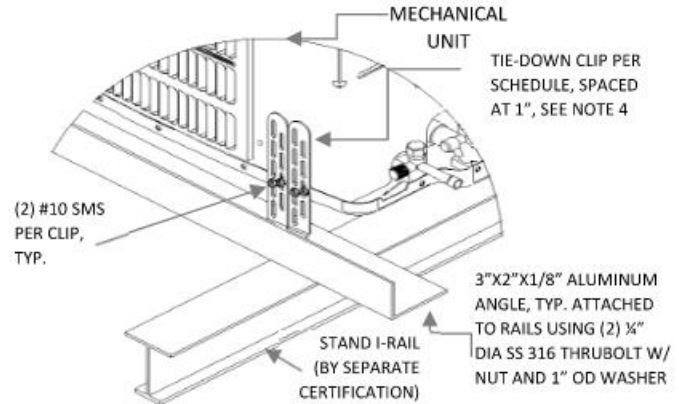

MECHANICAL UNIT TIE-DOWN DETAIL (SECTION C-C')

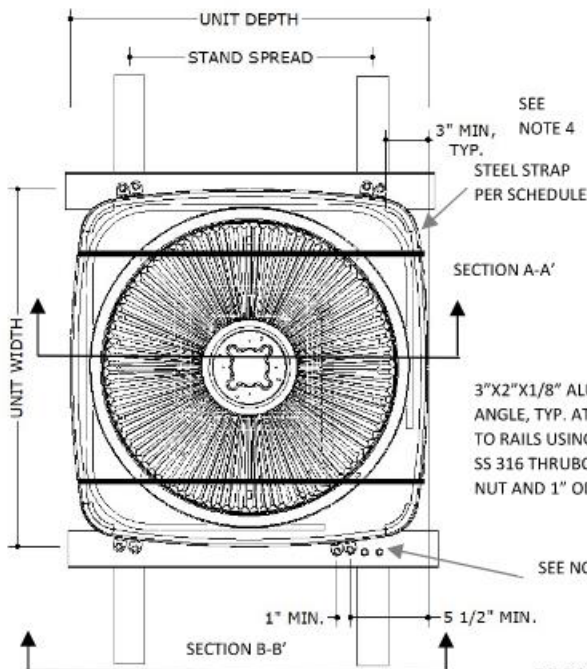

MECHANICAL UNIT ROOF MOUNTED PLAN VIEW

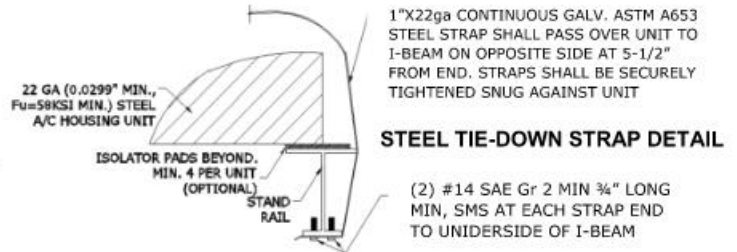

STEEL TIE-DOWN STRAP DETAIL

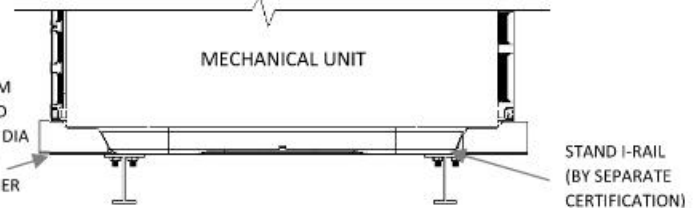

MECHANICAL UNIT RESTING ON STAND RAILS SIDE VIEW

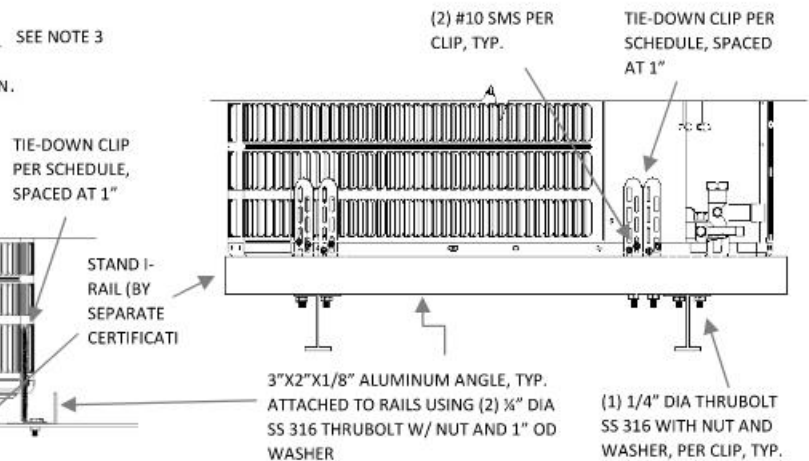

MECHANICAL UNIT RESTING ON STAND RAILS FRONT VIEW (SECTION B-B')

Note: Installers must ensure that screws used to fasten the tie-down clips with the unit base pan do not touch the coil preventing any damage. All pieces and installation parts per Miami Tech Hurricane kit #DGACUTD36K

TERMINOLOGY

The following abbreviations may appear in this report: "Addtl." for "additional", "AHJ" for "Authority Having Jurisdiction", "alum" for "aluminum", "ASCE" for "American Society of Civil Engineers", "ASD" for "Allowable Stress Design", "ASTM" for "American Society for Testing and Materials", "EA." for "each", "E.D." for "edge distance", "EDDS" for "extra deep drawing steel", "e.g." for "exempli gratia" or "for example", "equiv." for "equivalent", "FBC" for "Florida Building Code", "FEA" for "Finite Element Analysis", "FLCA" for "Florida Certificate of Authorization", "FS" for "Florida Statutes", "Fu" for "ultimate tensile strength" or "ultimate tensile stress", "Fy" for "yield strength" or "yield stress" "GA" for "gauge", "GR." or "Gr." for "grade", "HVAC" for "heating, ventilation, and air conditioning", "HVHZ" for "High-Velocity Hurricane Zone", "i.e." for "id est" or "in other words", "in" for "inch", "lb" for "pound (force)", "max." for "maximum", "min." for "minimum", "mm" for "millimeter", "NTS" for "not to scale", "O.C." for "on center", "OD" for "outer diameter", "PE" for "Professional Engineer", "qty" for "quantity", "SAE" for "Society of Automotive Engineering", "SMS" for "sheet metal screws", "SS" for "stainless steel", "TER" for "Technical Evaluation Report", "typ." for "typical", "U.N.O." for "unless noted otherwise", "UTS" for "ultimate tensile strength" or "ultimate tensile stress", "WLL" for "working load limit", "w/o" for "without", "YS" for "yield strength" or "yield stress", "#" for "number", "&" for "and", and "Ø" for "diameter". For additional abbreviation/terminology clarifications, please contact this office.

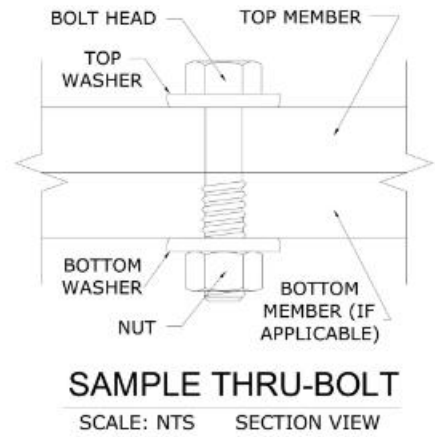

Note: The term "Thru-Bolt" or through bolt, if used herein, refers to a bolt passing through the member(s) in contact and is fastened by a nut at the end opposite the screw head. Nut shall be equivalent to or exceed the strength of the bolt U.N.O. Nut shall be sized to accommodate the same nominal diameter as the bolt U.N.O. See diagram above-right for a sample thru-bolt configuration.

Note: For instances herein which list material specifications as "[material type] or stronger": U.N.O. herein, the term "stronger" refers to a material with a UTS value equal to or greater than the UTS value of the stated material type. Consult appropriate literature for established material UTS values.

Note: Equivalent steel gauge thicknesses as used in this evaluation, U.N.O., are as follows: 22 GA (.030"), 20 GA (.036"), 18 GA (.048"), 16 GA (.060"), 14 GA (.075"), 12 GA (.098").

LIMITATIONS & CONDITIONS OF USE, CONTINUED

Use of this product shall be in strict accordance with this TER as noted herein. The supporting host structure shall be designed to resist all superimposed loads as determined by others on a site-specific basis as may be required by the authority having jurisdiction. Host structure conditions that are not accounted for in this product's respective anchor schedule shall be designed for on a site-specific basis by a registered Professional Engineer. No evaluation is offered for the host supporting structure by use of this document. Adjustment factors noted herein and the applicable building codes must be considered, where applicable. Product components shall be of the material(s) specified in the manufacturer-provided product specifications. All supporting components which are permanently installed shall be protected against corrosion, contamination, and other such damage at all times. All fasteners and anchors shall be installed in accordance with the applicable provisions specified herein in addition to the anchor/fastener manufacturers' published installation instructions. Fasteners must penetrate the supporting members such that the full length of the threaded portion is embedded within the main member.

All of the wind-resisting exterior panels (with accompanying retrofits) individually meet or exceed their capacity to resist the design wind loads as stated in the calculations as required by the codes and standards stated herein. Due to the indeterminate nature of these units, distortion, deflection, and material deformation cannot be accurately evaluated, but with the diaphragm action of external components and internal stiffeners, the base unit (with accompanying retrofits stated herein as applicable) has the capacity to withstand the design wind loads without detaching from the unit and becoming flying debris.

Survivability: Evaluation reports are valid for a newly installed unit and do not include certification of the product beyond a design event or if impacted by any debris. Inspections shall be implemented annually by the end user and after every named storm. All fasteners and cabinet components are to be verified, and all damaged, loose, corroded and/or broken fasteners and cabinet components shall be replaced to ensure structural integrity against hurricane wind forces. Contact this office for any reevaluation needs or as designated by the Authority Having Jurisdiction.

Durability: Components or component assemblies shall not deteriorate, crack, fail, or lose functionality due to galvanic corrosion or weathering. All supporting components which are permanently installed shall be protected against corrosion, contamination, and other such damage at all times. Each component or component assembly shall be supported and oriented in its intended installation position. All exposed plastic components shall be certified to resist sunlight exposure as specified by ASTM B117, or ASTM G155 in Broward or Miami Dade counties.

Extent of Certification: Certification pertains to the overall structural integrity of the unit components listed within the evaluation as required by code, subject to the limitations and criteria stated herein. Operability during or after a design event is not included in this certification. Water infiltration is outside the bounds of this certification. No other certifications are intended other than as described herein. This evaluation alone does not offer any evaluation for large missile impact debris or cyclic wind requirements unless specifically stated herein.

Proj. #	Remarks	By	Checked	Date	Proj. #	Remarks	By	Checked	Date
16-3146.2	Initial Issue	LAO	FLB	7/6/2016	20-34272	Add New Models & Template Update	MRT	EPR	1/20/2023
20-34272	2020 FBC Update	CCB	RWN	12/29/2020	20-34272	Add New Models	MRT	EPR	3/14/2023
20-34272	Add Models	MD	RS	7/12/22					

APPENDIX A: DESIGN WIND PRESSURE GUIDE

Max. Ult. Wind Speed (V _{ult})	Max. MRH (Roof Height)	Exposure Category	Required Design Wind Pressures (ASD)	
			Lateral Pressure	Uplift Pressure
140 mph	At-Grade (0 ft)	C	± 26 psf	0* psf
		D	± 31 psf	0* psf
	100 ft	C	± 63 psf	50 psf
		D	± 71 psf	56 psf
	200 ft	C	± 72 psf	57 psf
		D	± 80 psf	63 psf
175 mph	At-Grade (0 ft)	C	± 40 psf	0* psf
		D	± 49 psf	0* psf
	100 ft	C	± 98 psf	77 psf
		D	± 111 psf	87 psf
	200 ft	C	± 113 psf	89 psf
		D	± 124 psf	98 psf
186 mph	At-Grade (0 ft)	C	± 46 psf	0* psf
		D	± 54 psf	0* psf
	100 ft	C	± 111 psf	87 psf
		D	± 125 psf	99 psf
	200 ft	C	± 127 psf	100 psf
		D	± 140 psf	111 psf

100-psf

Note: Any table values with the format shown left, if present, indicate design wind pressures and site conditions that are **not approved for use** by this evaluation. Seek additional engineering or contact this firm for design solutions.

DIRECTIVE: This design pressure guide is for reference only and shall be approved for use by the Authority Having Jurisdiction (AHJ). If the design pressures listed in this guide are not used, required design pressures shall be calculated separately. For site-specific scenarios classified as Exposure Category B, the required design pressures stated for Exposure Category C in the above guide shall be used or design pressures shall be calculated separately. For heights and parameters beyond the parameters listed in this guide, visit our Online Calculator via the website link (<https://ecalcalc.io/forces>) or QR Code below, or obtain calculations separately by others.

The required ASD design pressures listed in this guide were calculated per the table's listed corresponding site conditions. The project design professional or permitting contractor shall verify that the site-specific conditions are equal to or less than the approved design parameters listed in the guide. Per the note below table: any values shown as "XX-psf", indicate wind pressures and corresponding site conditions that are **not valid for use** with this evaluation (exceeds the max. rated pressures).

*Note: Per the codes and standards referenced herein, uplift is not required for mechanical equipment at-grade. If uplift at-grade is required by the AHJ, contact this firm for a site-specific evaluation.

At-Grade (0 ft MRH) Required Design Pressures:

- o ASCE 7 "Design Wind Loads: Other Structures"
- o Structure Shape = Square, flat terrain
- o Height of structure (unit + stand or curb, if used) = 6 ft max.
- o Width of unit = 1 ft min., Depth of unit = 11 in min.

Rooftop (>15 ft MRH) Required Design Pressures:

- o ASCE 7 "Design Wind Loads: Other Structures: Rooftop Structures and Equipment for Buildings"
- o Structure Shape = Square, flat terrain
- o z = up to 7 ft, where z = height of stand or curb + ½ unit height
- o Lateral GC_r = 1.90; Uplift GC_r = 1.50

VISIT [ECALC.IO/FORCES](https://ecalcalc.io/forces)

FOR DESIGN AID CALCULATORS AND RESOURCES RELATED TO THIS TER & GUIDES HEREIN, OR SCAN THE QR CODE RIGHT >



UNIT REACTIONS FROM WIND GUIDE

DIRECTIVE: This guide is intended for use by a design professional. Design parameters shall abide all specifications and limitations stated in this report. Design professional shall consider all forces, including seismic and snow loads, per the governing building code. Unit reactions obtained from this guide shall be verified by a registered Professional Engineer. Reactions are applicable for unit-to-host connections only. Sample calculations are provided below.

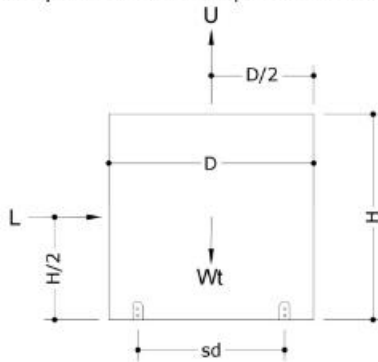

Design Parameters:

- Lateral Wind Pressure, P_{lat}
- Unit Height, H
- Unit Width, W
- Support Spacing across Depth, sd
- Uplift Wind Pressure, P_{up}
- Unit Depth, D
- Unit Weight, Wt
- Support Spacing across Width, sw

Unit Reaction Equations:

Long Side (Width x Height):

- Sliding Force, L = P_{lat} x W x H
- Uplift Force, U = P_{up} x W x D
- Total Tension per Long Side = (L x H/2 + U x sd/2 - Wt x 0.6 x sd/2) / sd

Short Side (Depth x Height):

- Sliding Force, L = P_{lat} x D x H
- Uplift Force, U = P_{up} x W x D
- Total Tension per Short Side = (L x H/2 + U x sw/2 - Wt x 0.6 x sw/2) / sw

Example: A (48" W x 36" D x 42" H), 250 lb net weight unit at wind pressures of 120 psf lateral and 95 psf uplift, on a 24" wide roof stand, shall have the following unit reactions:

Long Side (Width x Height):

1. Sliding Force, L = P_{lat} x W x H = (120 psf) x (48 in) x (42 in) x (1 in² / 144 ft²) = **1680 lb**
2. Uplift Force, U = P_{up} x W x D = (95 psf) x (48 in) x (36 in) x (1 in² / 144 ft²) = **1140 lb**
3. Total Tension per Long Side = (L x H/2 + U x sd/2 - Wt x 0.6 x sd/2) / sd = ((1680 lb x 42/2 in) + (1140 lb x 24/2 in) - (250 lb x 0.6 x 24/2 in)) / 24 in = **1965 lb**

Short Side (Depth x Height):

1. Sliding Force, L = P_{lat} x D x H = (120 psf) x (36 in) x (42 in) x (1 in² / 144 ft²) = **1260 lb**
2. Uplift Force, U = P_{up} x W x D = (95 psf) x (48 in) x (36 in) x (1 in² / 144 ft²) = **1140 lb**
3. Total Tension per Short Side = (L x H/2 + U x sw/2 - Wt x 0.6 x sw/2) / sw = ((1260 lb x 42/2 in) + (1140 lb x 48/2 in) - (250 lb x 0.6 x 48/2 in)) / 48 in = **1046 lb**

IN ALL CONDITIONS IT IS THE RESPONSIBILITY OF THE PERMIT HOLDER TO ENSURE THE HOST STRUCTURE IS CAPABLE OF WITHSTANDING THE RATED GRAVITY, LATERAL, AND UPLIFT FORCES BY SITE-SPECIFIC DESIGN. NO WARRANTY OF ANY KIND, EXPRESSED OR IMPLIED, IS OFFERED BY ENGINEERING EXPRESS AS TO THE INTEGRITY OF THE HOST STRUCTURE TO CARRY DESIGN FORCE LOADS INCURRED BY THIS UNIT.

THIS DOCUMENT CONTAINS (9) PAGES.
ENGINEER DIGITAL OR ORIGINAL HAND SEAL REQUIRED FOR USE.
COPIES ARE NOT VALID FOR PERMIT.

(Subject to Renew January 1, 2025 or next code cycle)

EVALUATION SUBJECT: **GOODMAN SPLIT UNITS**

TER-20-34290

REPORT HOLDER:

DAIKIN COMFORT TECHNOLOGIES MANUFACTURING, L.P.
19001 KERMIER ROAD
WALLER, TX 77484, USA
877-254-4729 | GOODMANMFG.COM



SCOPE OF EVALUATION (compliance with the following codes):

THIS IS A STRUCTURAL (WIND) PERFORMANCE EVALUATION ONLY. NO ELECTRICAL OR TEMPERATURE PERFORMANCE RATINGS OR CERTIFICATIONS ARE OFFERED OR IMPLIED HEREIN. UNDER NO CIRCUMSTANCE DOES THIS PERFORMANCE EVALUATION GUARANTEE, IMPLY, OR STATE PERFORMANCE OF THE UNIT IS MAINTAINED DURING OR AFTER A DESIGN EVENT.

This Product Evaluation Report is being issued in accordance with the requirements of the **Florida Building Code Seventh Edition (2020)** per ASCE 7, FBC Building Ch. 16, FBC Building Sections 104.11 & 1522.2, FBC Existing Building Sections 707.1 & 707.2, FBC Mechanical 301.15, FBC Residential M1202.1 & M1301.1, FS 471.025, and Broward County Administrative Provisions 107.3.4. This report is also in accordance with the **International Building & Residential Codes (2012, 2015, & 2018)**. The product noted on this report has been tested and/or evaluated as summarized herein.

IN ACCORDANCE WITH THESE CODES EACH OF THESE REPORTS MUST BEAR THE ORIGINAL SIGNATURE & RAISED SEAL OR DIGITAL SEAL OF THE EVALUATING ENGINEER.

SUBSTANTIATING DATA:

• **Product Evaluation Documents**

Substantiating documentation has been submitted to provide this TER and is summarized in the sections below.

• **Structural Engineering Calculations**

Structural engineering calculations have been prepared which evaluate the product based on comparative and/or rational analysis to qualify the following design criteria:

- Max. allowable lateral & uplift wind pressures certified herein
- Max. allowable sliding forces, uplift forces, & overturning moments (see Unit Reactions from Wind Guide on last page)
- Tie-down configuration and anchor capacity for concrete, aluminum, and steel host substrates (host by others).
- Unit panel wind pressure connection integrity

Calculation summary is included in this TER and appears herein. NOTE: No 33% increase in allowable stress has been used in the design of this product.

LIMITATIONS & CONDITIONS OF USE:

Use of the product(s) listed herein shall be in strict accordance with this TER as noted herein and manufacturer-provided model specifications. Installation shall conform to the minimum standards stated in the referenced building code(s) in addition to the specifications and limitations stated herein. See herein for complete limitations & conditions of use.

OPTIONS:

This evaluation is valid for the GOODMAN models described herein. The critical unit designs have been determined and used in this evaluation. Any structural changes outside of the design as described herein would void this certification.

UNIT CASING MATERIALS:

26 GA thick, ASTM A653 CS cold-rolled galv. steel for side covers. 22 GA thick, ASTM A653 cold-rolled galv. steel for bottom base pan. 20 GA thick, ASTM A653 cold-rolled galv. steel for top panel. Removable top & side covers secured with #10-12 sheet metal screws. Knockouts provided for utility & control connections. Contact Report Holder for further unit construction information.

NOTE: THE GRAPHICAL DEPICTIONS IN THIS REPORT ARE FOR ILLUSTRATIVE PURPOSES ONLY AND MAY DIFFER IN APPEARANCE.

STRUCTURAL PERFORMANCE:

Models referenced herein are subject to the following design limitations:

Maximum Rated Wind Pressures*:
± 119 psf Lateral, 94 psf Uplift

- Required design wind pressures shall be determined according to the guide provided in the Appendix (see last page of this report) or on a site-specific basis in accordance with ASCE 7 and applicable sections of the building code(s) being referenced in accordance with ASD methodology.
- Required design pressures shall be less than or equal to the maximum pressures listed herein.
- *Maximum Rated Wind Pressures indicate the maximum pressures that all units listed herein are approved for. Valid for at-grade and rooftop applications. See limitations herein.
- Valid for use inside and outside the High-Velocity Hurricane Zone (HVHZ).
- Site-specific wind analysis may produce alternate limitations provided maximum rated wind pressures stated herein are not exceeded.

VISIT ECALC.IO/DAIKIN

FOR ENGINEER CERTIFIED ORIGINALS & MORE INFORMATION ABOUT THIS DOCUMENT OR SCAN THE QR CODE TO THE RIGHT >

VISIT ENGINEERINGEXPRESS.COM/STORE FOR ADDITIONAL PLANS, REPORTS & RESOURCES



ORIGINAL SIGNATURE AND RAISED SEAL
OR DIGITAL SEAL REQUIRED TO BE VALID PER CODE:



VALID ONLY FOR ZIP CODE: 00000
VALID ONLY FOR MANUFACTURER'S RECORDS ONLY
NOT VALID FOR PERMIT OR CONSTRUCTION USE
PE0046549 CA-9885

DIGITAL SEAL NOTICE: IF THIS DOCUMENT IS DIGITALLY SIGNED, THIS SHEET IS PART OF A DIGITALLY SIGNED FILE. IT SHALL REMAIN IN DIGITAL FORMAT, SHALL BE VERIFIED BY ELECTRONIC MEANS, & PRINTED COPIES OF THIS DOCUMENT ARE NOT CONSIDERED SIGNED AND SEALED. VISIT ECALC.IO/DS FOR MORE INFORMATION.

PRINTED DOCUMENT NOTICE: IF THIS DOCUMENT IS PRINTED & DOES NOT CONTAIN AN ENGINEER'S ORIGINAL SIGNATURE & SEAL, THIS DOCUMENT IS VOID & NOT VALID FOR USE. PHOTOCOPIES ARE NOT PERMITTED FOR USE.

MODEL INFORMATION (CONTINUED ON NEXT PAGES)

Cabinet Group	Model Number	Unit Dimensions (in)		
		Width	Depth	Height
C2	DSXC160241	29	29	32.25
C2	DSXC160361	29	29	38.25
D1	DSXC160481	35.5	35.5	36.25
D3	DSXC160601	35.5	35.5	38.25
D3	DSXC180361	35.5	35.5	38.25
D3	DSXC180481	35.5	35.5	38.25
D3	DSXC180601	35.5	35.5	38.25
C4	DSZC160241	29	29	38.25
D3	DSZC160361	35.5	35.5	38.25
D3	DSZC160481	35.5	35.5	38.25
D3	DSZC160601	35.5	35.5	38.25
D3	DSZC180361	35.5	35.5	38.25
D3	DSZC180481	35.5	35.5	38.25
D3	DSZC180601	35.5	35.5	38.25
A1	GSX130181	23	23	25.75
B1	GSX130241	26	26	27.5
B1	GSX130301	26	26	27.5
B1	GSX130361	26	26	27.5
C3	GSX130421	29	29	36.25
C3	GSX130481	29	29	36.25
C6	GSX130601	29	29	40
D5	GSX130611	35.5	35.5	38.25
B1	GSX140181	26	26	27.5
A1	GSX140181-M*	23	23	25
B1	GSX140191	26	26	27.5
B1	GSX140241	26	26	27.5
B2	GSX140251	26	26	32.5
C2	GSX140301	29	29	32.5
C2	GSX140311	29	29	32.5
C2	GSX140361	29	29	32.5

Cabinet Group	Model Number	Unit Dimensions (in)		
		Width	Depth	Height
C2	GSX140371	29	29	32.5
C3	GSX140421	29	29	36.25
C3	GSX140431	29	29	36.25
D1	GSX140481	35.5	35.5	36.25
D5	GSX140601	35.5	35.5	38.25
C2	GSX16*181A*	29	29	32
C2	GSX16*241A*	29	29	32
C3	GSX16*301A*	29	29	35.75
D6	GSX16*361A*	29	29	39.5
D1	GSX16*421A*	35.5	35.5	35.75
D6	GSX16*481A*	35.5	35.5	39.5
C2	GSX160181	29	29	32.25
C2	GSX160241	29	29	32.25
C3	GSX160301	29	29	36.25
C3	GSX160311A	29	29	38.25
C6	GSX160361	29	29	38.25
D1	GSX160371A	35.5	35.5	36.25
D1	GSX160421	35.5	35.5	36.25
D3	GSX160481	35.5	35.5	36.25
D5	GSX160601	35.5	35.5	38.25
D5	GSX160611	35.5	35.5	38.25
B2	GSXB401810	26	26	32½
C2	GSXB402410	29	29	32
D6	GSXB403010	35½	35½	39½
D6	GSXB403610	35½	35½	39½
D1	GSXB404210	35½	35½	36½
D1	GSXB404810	35½	35½	36½
D6	GSXB406010	35½	35½	41½
C2	GSXC160241	29.25	29.25	32.5
D1	GSXC160361	35.75	35.75	36.5

Note:

The model numbers on this page may be followed by up to two (2) alphanumeric characters. Those characters will not affect the structural performance, since they refer to minor/major changes not related to the cabinet structure.

MODEL INFORMATION (CONTINUED FROM PREVIOUS PAGE)

Cabinet Group	Model Number	Unit Dimensions (in)		
		Width	Depth	Height
D3	GSXC160481	35.75	35.75	37
D6	GSXC160601	35.75	35.75	42.25
D6	GSXC180241	35.75	35.75	40
D6	GSXC180361	35.75	35.75	40
D6	GSXC180481	35.75	35.75	42.25
D6	GSXC180601	35.75	35.75	42.25
D6	GSXC702410	35½	35½	39½
D6	GSXC703610	35½	35½	39½
D6	GSXC704810	35½	35½	41¼
D6	GSXC706010	35½	35½	41¼
B1	GSXH501810	26	26	27
B2	GSXH502410	29	29	32
D6	GSXH503010	35½	35½	39½
D6	GSXH503610	35½	35½	39½
D1	GSXH504210	35½	35½	36½
D1	GSXH504810	35½	35½	36½
D6	GSXH506010	35½	35½	41¼
B1	GSXM401810	26	26	27
C2	GSXM402410	29	29	32
D6	GSXM403010	35½	35½	39½
D6	GSXM403610	35½	35½	39½
B1	GSXN401810	26	26	27
B2	GSXN402410	26	26	32¼
C4	GSXN403010	29	29	39½
D1	GSXN403610	35½	35½	35¼
D6	GSXN404210	35½	35½	39½
D6	GSXN404810	35½	35½	39½
D1	GSXN406010	35½	35½	36½
D4	GSXV902410	35.5	35.5	35
D4	GSXV903610	35.5	35.5	35

Cabinet Group	Model Number	Unit Dimensions (in)		
		Width	Depth	Height
D6	GSXV904810	35.5	35.5	42.25
D6	GSXV906010	35.5	35.5	42.25
C1	GSZ140181	29	29	34.5
C1	GSZ14019	29	29	34.5
C1	GSZ140241	29	29	34.5
C1	GSZ14025	29	29	34.5
C5	GSZ140301	29	29	36.25
D2	GSZ14031	35.5	35.5	34.63
C5	GSZ140361	29	29	36.25
D6	GSZ14037	35.5	35.5	40
D6	GSZ140421	35.5	35.5	39.75
C5	GSZ140481	29	29	36.25
D2	GSZ140491	35.5	35.5	34.5
D2	GSZ140601	35.5	35.5	34.5
C5	GSZ160181	29	29	36.38
D2	GSZ160241	35.5	35.5	34.63
D2	GSZ160301	35.5	35.5	34.63
D6	GSZ160361	35.5	35.5	40
C5	GSZ160421	29	29	36.38
D2	GSZ160481	35.5	35.5	34.63
D6	GSZ160601	35.5	35.5	40
C3	GSZB401810	29	29	35.75
C3	GSZB402410	29	29	35.75
C4	GSZB403010	29	29	39.5
D6	GSZB403610	35.5	35.5	39.5
D1	GSZB404210	35.5	35.5	35.75
D1	GSZB404810	35.5	35.5	36.5
D6	GSZB406010	35.5	35.5	41.63
D2	GSZC160241	35.5	35.5	34.63
D6	GSZC160361	35.5	35.5	40

Note:

The model numbers on this and previous page may be followed by up to two (2) alphanumeric characters. Those characters will not affect the structural performance, since they refer to minor/major changes not related to the cabinet structure.

MODEL INFORMATION (CONTINUED FROM PREVIOUS PAGE)

Cabinet Group	Model Number	Unit Dimensions (in)		
		Width	Depth	Height
D2	GSZC160481	35.5	35.5	34.63
D6	GSZC160601	35.5	35.5	40
D6	GSZC180241	35.5	35.5	40
D3	GSZC180361	35.5	35.5	34.63
D6	GSZC180481	35.5	35.5	40
D6	GSZC180601	35.5	35.5	40
D6	GSZC702410	35.5	35.5	39.5
D1	GSZC703610	35.5	35.5	35.75
D6	GSZC704810	35.5	35.5	41.63
D6	GSZC706010	35.5	35.5	41.63
C4	GSZH501810	29	29	39½
D1	GSZH502410	35½	35½	35¾
D6	GSZH503010	35½	35½	39½
D6	GSZH503610	35½	35½	39½
D1	GSZH504210	35½	35½	35¾
D1	GSZH504810	35½	35½	36½
D6	GSZH506010	35½	35½	41¾
C3	GSZM401810	29	29	35.75
C3	GSZM402410	29	29	35.75
C4	GSZM403010	29	29	39.5
D6	GSZM403610	35.5	35.5	39.5
D4	GSZV902410	35.5	35.5	35
D6	GSZV903610	35.5	35.5	42.25
D6	GSZV904810	35.5	35.5	42.25
D6	GSZV906010	35.5	35.5	42.25
B1	VSX140181	26	26	27.5
B1	VSX140191	26	26	27.5
B1	VSX140241	26	26	27.5
B1	VSX140251	26	26	27.5
C1	VSX140301	29	29	32.5

Cabinet Group	Model Number	Unit Dimensions (in)		
		Width	Depth	Height
C1	VSX140311	29	29	32.5
C1	VSX140361	29	29	32.5
C1	VSX140371	29	29	32.5
C2	VSX140421	29	29	36.25
C2	VSX140431	29	29	36.25
D1	VSX140481	35.5	35.5	36.25
D2	VSX140601	35.5	35.5	38.25
B1	VSXN401810	26	26	27
B2	VSXN402410	26	26	32½
C4	VSXN403010	29	29	39½
D1	VSXN403610	35½	35½	35¾
D6	VSXN404210	35½	35½	39½
D6	VSXN404810	35½	35½	39½
D1	VSXN406010	35½	35½	36½
C1	VSZ140181	29	29	34.5
C1	VSZ140241	29	29	34.5
C5	VSZ140301	29	29	36.25
C5	VSZ140361	29	29	36.25
D6	VSZ140421	35.5	35.5	39.75
C5	VSZ140481	29	29	36.25
D2	VSZ140491	35.5	35.5	34.5
D2	VSZ140601	35.5	35.5	34.5
C3	VSZN401810	29	29	35.75
C3	VSZN402410	29	29	35.75
C4	VSZN403010	29	29	39.5
D6	VSZN403610	35.5	35.5	39.5
D1	VSZN404210	35.5	35.5	35.75
D1	VSZN404810	35.5	35.5	36.5
D6	VSZN406010	35.5	35.5	41.63

Note:

The model numbers on this and previous page may be followed by up to two (2) alphanumeric characters. Those characters will not affect the structural performance, since they refer to minor/major changes not related to the cabinet structure.

MODEL INFORMATION NOTES

Unit dimensions listed above are unit net dimensions (as opposed to packing/shipping dimensions). Unit net weights shall be between 100 lb and 375 lb, typ. Model information listed herein is based on information provided by the client. See Detail below for definitions of unit dimensions. Unit appearance may vary. Please contact Report Holder for more information.

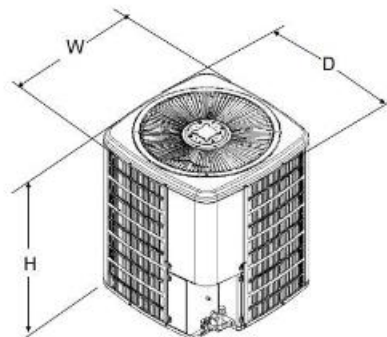

PRODUCT INSTALLATION

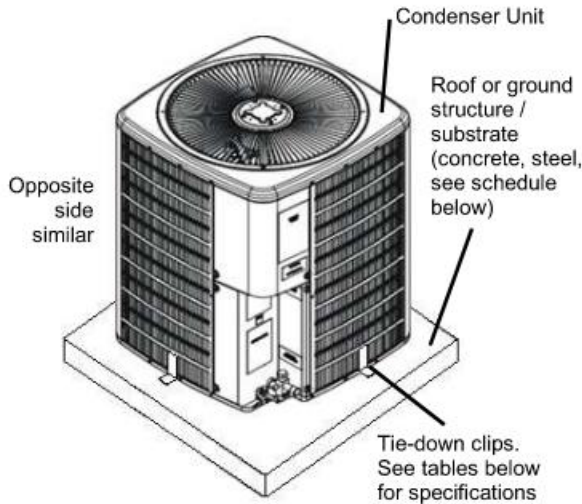

TIE-DOWN CLIP (GROUND APPLICATION)

ASTM A653 G60 galvanized cold rolled steel 0.072" thick for all cabinets tied down at ground (Goodman Bracket); fasten cabinet using (2) anchors per clip from Anchor to Host Structure Schedule Table. Clip integrates into base pan slot.



TIE-DOWN CLIP (GROUND & ROOF APPLICATIONS)

Miami Tech CUTD 1" wide and any length ASTM A653 galvanized steel 0.07" thick for all cabinets tied down to a roof structure; fasten clip to structure using anchor from Anchor Schedule to Host Structure Table and (2) #10 x 1/2" SS 410 self-drilling screw to fasten clip to unit base pan. See Tie-down Strap & Clip Schedule Table for clip amount. Hurricane kit #DGACUTD36K

Tie-Down Strap & Clip Schedule						
Unit Model	Max Lateral Pressure	Max Uplift Pressure	Strap Req'd?	Qty	Minimum WLL (lbs)	Tie Down Clips Needed
Cabinet A1	50 psf	39 psf	NO	N/A	N/A	4
	106 psf	84 psf	YES	2	300	8
	119 psf	94 psf	YES	2	400	8
Cabinet B1, B2	50 psf	39 psf	NO	N/A	N/A	4
	106 psf	84 psf	YES	2	400	8
	119 psf	94 psf	YES	2	400	8
Cabinet C1 to C6	50 psf	39 psf	NO	N/A	N/A	4
	106 psf	84 psf	YES	2	500	8
	119 psf	94 psf	YES	2	600	8
Cabinet D1 to D6	50 psf	39 psf	NO	N/A	N/A	4
	106 psf	84 psf	YES	2	600	8
	119 psf	94 psf	YES	2	600	8

Tie-Down Strap & Clip Schedule Notes:

Straps are not required for ground-mounted installations. Working Load Limit (WLL) is per the strap's manufacturer - specified per strap. A minimum strap width of 1" is required for all cabinets. Clip heights shall be adequate to fit SMS within base pan height. Verify height on site. For ground-mounted installations, clips shall be placed at the center of each side, equally spaced. For roof-mounted installations, see details herein for clip positioning. See next page for Anchor Schedule to Host Structure.

Note: (Vertical Strapping)

1. Tie-down straps shall be wrapped around unit and roof stand rail, and shall be tightened using the buckle. Provide two straps per unit.
2. Strap material shall be either high-strength webbing and shall be compliant for exterior grade use if they contain plastic components, per FBC chapter 26. Or 1" wide 22ga ASTM A653 steel strap secured with (2) #14 SS SMS to the bottom of the stand rail.

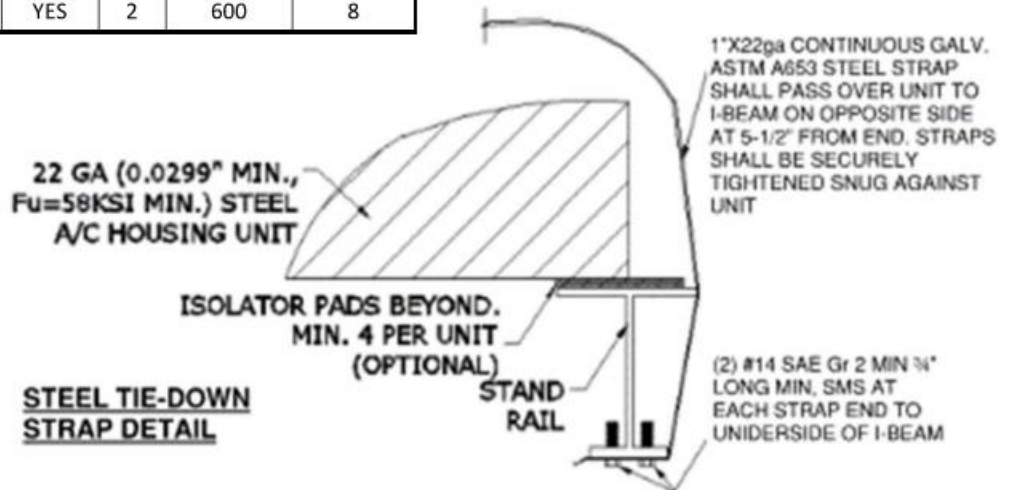

SEE NEXT PAGE FOR ANCHOR SCHEDULE TO HOST STRUCTURE (FOR TIE-DOWN CLIPS)

PRODUCT INSTALLATION CONTINUED

Anchor to Host Structure Schedule					
Cabinet	Max Lateral Pressure	Max Uplift Pressure	Concrete 3,000 psi	1/8" Min A36 Steel	1/8" Min 6061-T6 Aluminum
A1, B1-2, C1-6, D1-6	50 psf	39 psf	A	N/A	N/A
	119 psf	94 psf	N/A	B	B

Anchor Types to Host Structure:

A. – 1/4" DeWalt ULTRACON SS4 Anchor embedded 3" in 3,000 psi concrete. 2 1/2" from edge minimum.

B. – 1/4" -20 UNC SS 316 bolt min. 1/2" from edges with nut and 1" OD washer

NA. - No anchors apply.

PANEL INTEGRITY SUMMARY

Panel Integrity Summary			
Cabinet	Max Lateral Pressure	Max Uplift Pressure	Horizontal Strapping Required
A1, B1-2, C1-6, D1-6	50 psf	39 psf	NONE
	119 psf	94 psf	NONE

PANEL INTEGRITY SUMMARY NOTES

No horizontal strapping is required for all installations up to the maximum-rated wind pressures.

Panel integrity calculations were based on information provided by the client and manufacturer-listed specifications. Specifications herein apply to all unit models listed herein (see "Model Information" on page 2). Each unit cabinetry type was considered separately. All exterior panels were considered in the calculations and are covered by this certification. Panels were assigned various porosities depending on the ratio of louver/aperture area to total panel area, for the purposes of calculating the acting wind force on each panel. Screw sizes, quantities on panels, and panel characteristics were considered based on client-provided information and additional conservative assumptions. Screw quantities were checked to reinforce unit panels as needed.

The purpose of this panel integrity evaluation is to ensure exterior panel connection integrity, referred to herein as "panel integrity", is sufficiently validated, such that the panel in question can withstand a high-speed wind gust and not detach or otherwise become flying debris.

REMAINDER OF PAGE INTENTIONALLY LEFT BLANK

STRAP & CLIP LAYOUT FOR ROOF INSTALLATIONS

NOTES:

1. 3"x2"x1/8" ALUMINUM ANGLE SHALL BE 6061-T6 AND SHALL OVERHANG 8" MAXIMUM FROM STAND RAIL PER SIDE.
2. CONDENSER SHALL REST ON TOP OF THE STAND RAILS.
3. CLIPS MAY NOT COINCIDE WITH RAIL BELOW, ATTACHED ANGLE USING (2) 1/4" THROBOLT W/ NUT AND 1.0 OD WASHER.
4. TIE-DOWN CLIPS FOR CABINETS EQUAL OR SMALLER THAN 26" WIDE SHALL BE LOCATED 1" FROM EDGE MIN.

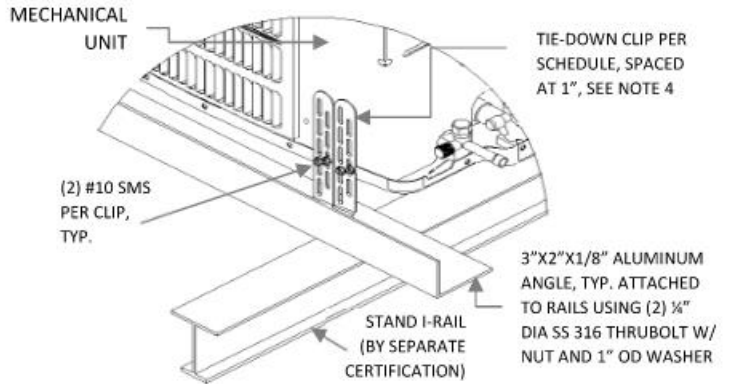
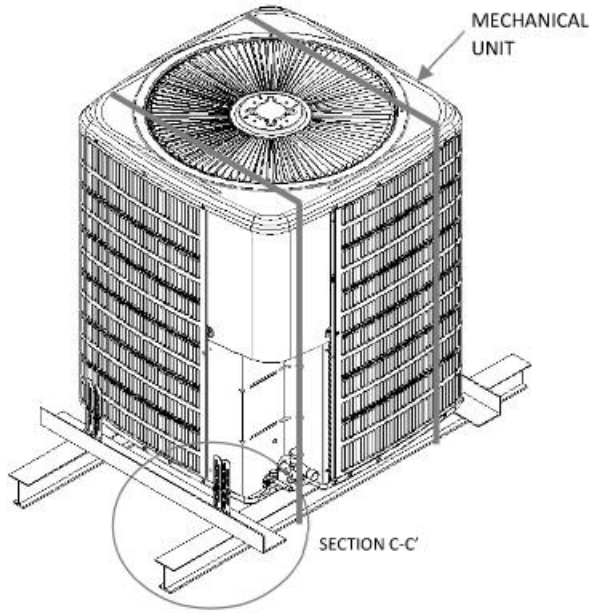

MECHANICAL UNIT TIE-DOWN DETAIL (SECTION C-C')

MECHANICAL UNIT ROOF MOUNTED ISOMETRIC

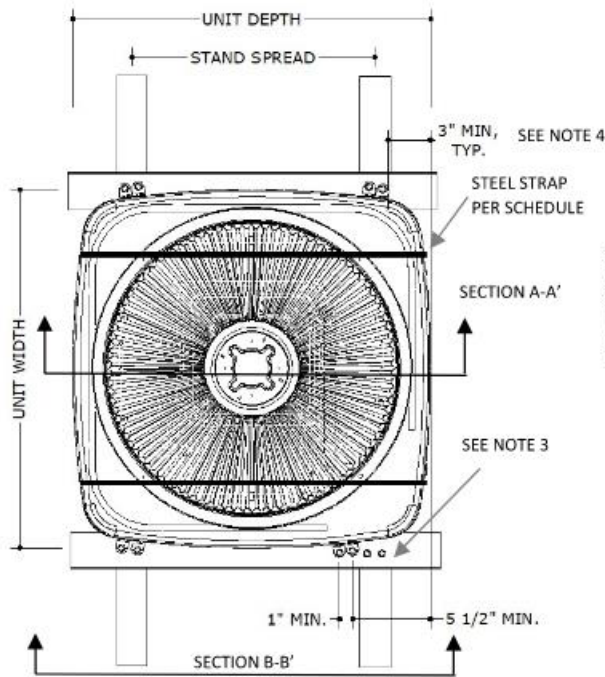

MECHANICAL UNIT ROOF MOUNTED PLAN VIEW

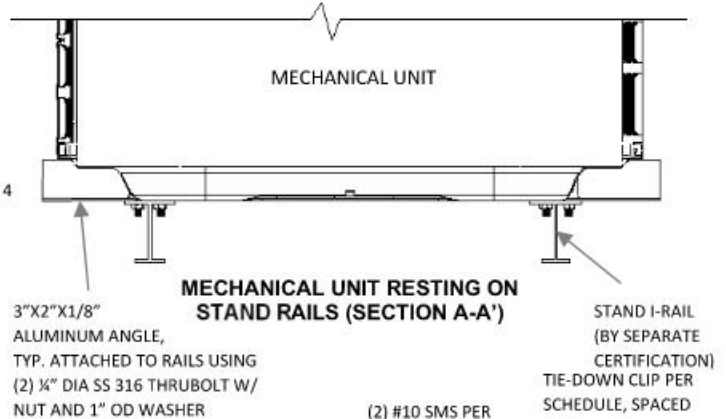

MECHANICAL UNIT RESTING ON STAND RAILS (SECTION A-A')

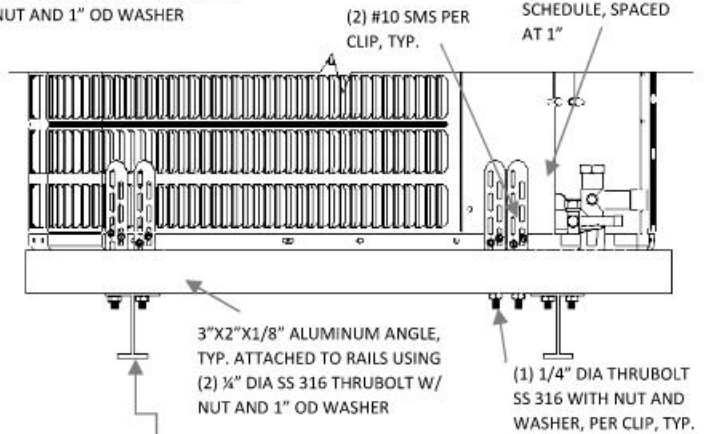

MECHANICAL UNIT RESTING ON STAND RAILS FRONT VIEW (SECTION B-B')

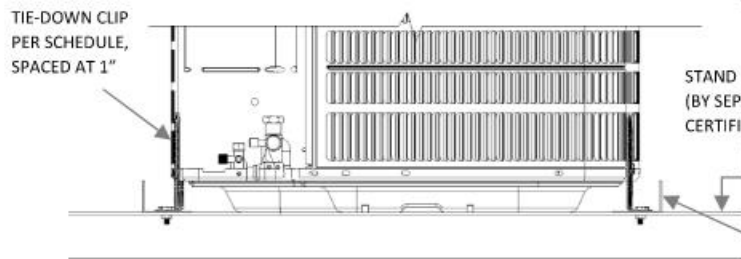

MECHANICAL UNIT RESTING ON STAND RAILS - SIDE VIEW

Note: Installers must ensure that screws used to fasten the tie-down clips with the unit base pan do not touch the coil preventing any damage. All pieces and installation parts per Miami Tech Hurricane kit #DGACUTD36K

TERMINOLOGY

The following abbreviations may appear in this report: "Addtl." for "additional", "AHJ" for "Authority Having Jurisdiction", "alum" for "aluminum", "ASCE" for "American Society of Civil Engineers", "ASD" for "Allowable Stress Design", "ASTM" for "American Society for Testing and Materials", "EA." for "each", "E.D." for "edge distance", "EDDS" for "extra deep drawing steel", "e.g." for "exempli gratia" or "for example", "equiv." for "equivalent", "FBC" for "Florida Building Code", "FEA" for "Finite Element Analysis", "FLCA" for "Florida Certificate of Authorization", "FS" for "Florida Statutes", "Fu" for "ultimate tensile strength" or "ultimate tensile stress", "Fy" for "yield strength" or "yield stress" "GA" for "gauge", "GR." or "Gr." for "grade", "HVAC" for "heating, ventilation, and air conditioning", "HVHZ" for "High-Velocity Hurricane Zone", "i.e." for "id est" or "in other words", "in" for "inch", "lb" for "pound (force)", "max." for "maximum", "min." for "minimum", "mm" for "millimeter", "NTS" for "not to scale", "O.C." for "on center", "OD" for "outer diameter", "PE" for "Professional Engineer", "qty" for "quantity", "SAE" for "Society of Automotive Engineering", "SMS" for "sheet metal screws", "SS" for "stainless steel", "TER" for "Technical Evaluation Report", "typ." for "typical", "U.N.O." for "unless noted otherwise", "UTS" for "ultimate tensile strength" or "ultimate tensile stress", "WLL" for "working load limit", "w/o" for "without", "YS" for "yield strength" or "yield stress", "#" for "number", "&" for "and", and "Ø" for "diameter". For additional abbreviation/terminology clarifications, please contact this office.

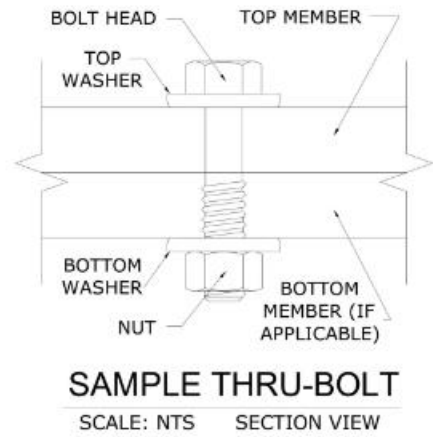

Note: The term "Thru-Bolt" or through bolt, if used herein, refers to a bolt passing through the member(s) in contact and is fastened by a nut at the end opposite the screw head. Nut shall be equivalent to or exceed the strength of the bolt U.N.O. Nut shall be sized to accommodate the same nominal diameter as the bolt U.N.O. See diagram above-right for a sample thru-bolt configuration.

Note: For instances herein which list material specifications as "[material type] or stronger": U.N.O. herein, the term "stronger" refers to a material with a UTS value equal to or greater than the UTS value of the stated material type. Consult appropriate literature for established material UTS values.

Note: Equivalent steel gauge thicknesses as used in this evaluation, U.N.O., are as follows: 22 GA (.030"), 20 GA (.036"), 18 GA (.048"), 16 GA (.060"), 14 GA (.075"), 12 GA (.098").

LIMITATIONS & CONDITIONS OF USE, CONTINUED

Use of this product shall be in strict accordance with this TER as noted herein. The supporting host structure shall be designed to resist all superimposed loads as determined by others on a site-specific basis as may be required by the authority having jurisdiction. Host structure conditions that are not accounted for in this product's respective anchor schedule shall be designed for on a site-specific basis by a registered Professional Engineer. No evaluation is offered for the host supporting structure by use of this document. Adjustment factors noted herein and the applicable building codes must be considered, where applicable. Product components shall be of the material(s) specified in the manufacturer-provided product specifications. All supporting components which are permanently installed shall be protected against corrosion, contamination, and other such damage at all times. All fasteners and anchors shall be installed in accordance with the applicable provisions specified herein in addition to the anchor/fastener manufacturers' published installation instructions. Fasteners must penetrate the supporting members such that the full length of the threaded portion is embedded within the main member.

All of the wind-resisting exterior panels (with accompanying retrofits) individually meet or exceed their capacity to resist the design wind loads as stated in the calculations as required by the codes and standards stated herein. Due to the indeterminate nature of these units, distortion, deflection, and material deformation cannot be accurately evaluated, but with the diaphragm action of external components and internal stiffeners, the base unit (with accompanying retrofits stated herein as applicable) has the capacity to withstand the design wind loads without detaching from the unit and becoming flying debris.

Survivability: Evaluation reports are valid for a newly installed unit and do not include certification of the product beyond a design event or if impacted by any debris. Inspections shall be implemented annually by the end user and after every named storm. All fasteners and cabinet components are to be verified, and all damaged, loose, corroded and/or broken fasteners and cabinet components shall be replaced to ensure structural integrity against hurricane wind forces. Contact this office for any reevaluation needs or as designated by the Authority Having Jurisdiction.

Durability: Components or component assemblies shall not deteriorate, crack, fail, or lose functionality due to galvanic corrosion or weathering. All supporting components which are permanently installed shall be protected against corrosion, contamination, and other such damage at all times. Each component or component assembly shall be supported and oriented in its intended installation position. All exposed plastic components shall be certified to resist sunlight exposure as specified by ASTM B117, or ASTM G155 in Broward or Miami Dade counties.

Extent of Certification: Certification pertains to the overall structural integrity of the unit components listed within the evaluation as required by code, subject to the limitations and criteria stated herein. Operability during or after a design event is not included in this certification. Water infiltration is outside the bounds of this certification. No other certifications are intended other than as described herein. This evaluation alone does not offer any evaluation for large missile impact debris or cyclic wind requirements unless specifically stated herein.

Proj. #	Remarks	By	Checked	Date	Proj. #	Remarks	By	Checked	Date
16-3146.4	Initial Issue	LAO	FLB	07/06/16	20-34290	Add Models	EPR	EPR	07/20/22
20-34290	Update to 2020 FBC	CCB	RWN	12/29/20	20-34290	Add Models	MRT	EPR	03/14/23
20-34290	Add Models	EPR	EPR	07/05/22					

APPENDIX A: DESIGN WIND PRESSURE GUIDE

Max. Ult. Wind Speed (V _{ult})	Max. MRH (Roof Height)	Exposure Category	Required Design Wind Pressures (ASD)	
			Lateral Pressure	Uplift Pressure
140 mph	At-Grade (0 ft)	C	± 26 psf	0* psf
		D	± 31 psf	0* psf
	100 ft	C	± 63 psf	50 psf
		D	± 71 psf	56 psf
	200 ft	C	± 72 psf	57 psf
		D	± 80 psf	63 psf
175 mph	At-Grade (0 ft)	C	± 40 psf	0* psf
		D	± 49 psf	0* psf
	100 ft	C	± 98 psf	77 psf
		D	± 111 psf	87 psf
	200 ft	C	± 113 psf	89 psf
		D	± 124 psf	98 psf
186 mph	At-Grade (0 ft)	C	± 46 psf	0* psf
		D	± 54 psf	0* psf
	100 ft	C	± 111 psf	87 psf
		D	± 125 psf	99 psf
	200 ft	C	± 127 psf	100 psf
		D	± 140 psf	111 psf

100-psf

Note: Any table values with the format shown left, if present, indicate design wind pressures and site conditions that are **not approved for use** by this evaluation. Seek additional engineering or contact this firm for design solutions.

DIRECTIVE: This design pressure guide is for reference only and shall be approved for use by the Authority Having Jurisdiction (AHJ). If the design pressures listed in this guide are not used, required design pressures shall be calculated separately. For site-specific scenarios classified as Exposure Category B, the required design pressures stated for Exposure Category C in the above guide shall be used or design pressures shall be calculated separately. For heights and parameters beyond the parameters listed in this guide, visit our Online Calculator via the website link (<https://ecalcalc.io/forces>) or QR Code below, or obtain calculations separately by others.

The required ASD design pressures listed in this guide were calculated per the table's listed corresponding site conditions. The project design professional or permitting contractor shall verify that the site-specific conditions are equal to or less than the approved design parameters listed in the guide. Per the note below table: any values shown as "XX-psf", indicate wind pressures and corresponding site conditions that are **not valid for use** with this evaluation (exceeds the max. rated pressures).

*Note: Per the codes and standards referenced herein, uplift is not required for mechanical equipment at-grade. If uplift at-grade is required by the AHJ, contact this firm for a site-specific evaluation.

At-Grade (0 ft MRH) Required Design Pressures:

- o ASCE 7 "Design Wind Loads: Other Structures"
- o Structure Shape = Square, flat terrain
- o Height of structure (unit + stand or curb, if used) = 6 ft max.
- o Width of unit = 1 ft min., Depth of unit = 11 in min.

Rooftop (>15 ft MRH) Required Design Pressures:

- o ASCE 7 "Design Wind Loads: Other Structures: Rooftop Structures and Equipment for Buildings"
- o Structure Shape = Square, flat terrain
- o z = up to 7 ft, where z = height of stand or curb + ½ unit height
- o Lateral GC_r = 1.90; Uplift GC_r = 1.50

VISIT [ECALC.IO/FORCES](https://ecalcalc.io/forces)

FOR DESIGN AID CALCULATORS AND RESOURCES RELATED TO THIS TER & GUIDES HEREIN, OR SCAN THE QR CODE RIGHT >



UNIT REACTIONS FROM WIND GUIDE

DIRECTIVE: This guide is intended for use by a design professional. Design parameters shall abide all specifications and limitations stated in this report. Design professional shall consider all forces, including seismic and snow loads, per the governing building code. Unit reactions obtained from this guide shall be verified by a registered Professional Engineer. Reactions are applicable for unit-to-host connections only. Sample calculations are provided below.

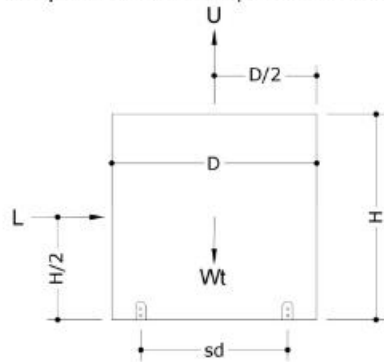

Design Parameters:

- Lateral Wind Pressure, P_{lat}
- Unit Height, H
- Unit Width, W
- Support Spacing across Depth, sd
- Uplift Wind Pressure, P_{up}
- Unit Depth, D
- Unit Weight, Wt
- Support Spacing across Width, sw

Unit Reaction Equations:

Long Side (Width x Height):

- Sliding Force, L = P_{lat} x W x H
- Uplift Force, U = P_{up} x W x D
- Total Tension per Long Side = (L x H/2 + U x sd/2 - Wt x 0.6 x sd/2) / sd

Short Side (Depth x Height):

- Sliding Force, L = P_{lat} x D x H
- Uplift Force, U = P_{up} x W x D
- Total Tension per Short Side = (L x H/2 + U x sw/2 - Wt x 0.6 x sw/2) / sw

Example: A (48" W x 36" D x 42" H), 250 lb net weight unit at wind pressures of 120 psf lateral and 95 psf uplift, on a 24" wide roof stand, shall have the following unit reactions:

Long Side (Width x Height):

- Sliding Force, L = P_{lat} x W x H = (120 psf) x (48 in) x (42 in) x (1 in² / 144 ft²) = **1680 lb**
- Uplift Force, U = P_{up} x W x D = (95 psf) x (48 in) x (36 in) x (1 in² / 144 ft²) = **1140 lb**
- Total Tension per Long Side = (L x H/2 + U x sd/2 - Wt x 0.6 x sd/2) / sd = ((1680 lb x 42/2 in) + (1140 lb x 24/2 in) - (250 lb x 0.6 x 24/2 in)) / 24 in = **1965 lb**

Short Side (Depth x Height):

- Sliding Force, L = P_{lat} x D x H = (120 psf) x (36 in) x (42 in) x (1 in² / 144 ft²) = **1260 lb**
- Uplift Force, U = P_{up} x W x D = (95 psf) x (48 in) x (36 in) x (1 in² / 144 ft²) = **1140 lb**
- Total Tension per Short Side = (L x H/2 + U x sw/2 - Wt x 0.6 x sw/2) / sw = ((1260 lb x 42/2 in) + (1140 lb x 48/2 in) - (250 lb x 0.6 x 48/2 in)) / 48 in = **1046 lb**

IN ALL CONDITIONS IT IS THE RESPONSIBILITY OF THE PERMIT HOLDER TO ENSURE THE HOST STRUCTURE IS CAPABLE OF WITHSTANDING THE RATED GRAVITY, LATERAL, AND UPLIFT FORCES BY SITE-SPECIFIC DESIGN. NO WARRANTY OF ANY KIND, EXPRESSED OR IMPLIED, IS OFFERED BY ENGINEERING EXPRESS AS TO THE INTEGRITY OF THE HOST STRUCTURE TO CARRY DESIGN FORCE LOADS INCURRED BY THIS UNIT.

THIS DOCUMENT CONTAINS (7) PAGES.
ENGINEER DIGITAL OR ORIGINAL HAND SEAL REQUIRED FOR USE.
COPIES ARE NOT VALID FOR PERMIT.

(Subject to Renew January 1, 2025 or next code cycle)

EVALUATION SUBJECT: **AMANA SPLIT UNITS**

TER-20-34275

REPORT HOLDER:

DAIKIN COMFORT TECHNOLOGIES MANUFACTURING, L.P.
19001 KERMIER ROAD
WALLER, TX 77484, USA
877-254-4729 | AMANA-HAC.COM



SCOPE OF EVALUATION (compliance with the following codes):

THIS IS A STRUCTURAL (WIND) PERFORMANCE EVALUATION ONLY. NO ELECTRICAL OR TEMPERATURE PERFORMANCE RATINGS OR CERTIFICATIONS ARE OFFERED OR IMPLIED HEREIN. UNDER NO CIRCUMSTANCE DOES THIS PERFORMANCE EVALUATION GUARANTEE, IMPLY, OR STATE PERFORMANCE OF THE UNIT IS MAINTAINED DURING OR AFTER A DESIGN EVENT.

This Product Evaluation Report is being issued in accordance with the requirements of the **Florida Building Code Seventh Edition (2020)** per ASCE 7, FBC Building Ch. 16, FBC Building Sections 104.11 & 1522.2, FBC Existing Building Sections 707.1 & 707.2, FBC Mechanical 301.15, FBC Residential M1202.1 & M1301.1, FS 471.025, and Broward County Administrative Provisions 107.3.4. This report is also in accordance with the **International Building & Residential Codes (2012, 2015, & 2018)**. The product noted on this report has been tested and/or evaluated as summarized herein.

IN ACCORDANCE WITH THESE CODES EACH OF THESE REPORTS MUST BEAR THE ORIGINAL SIGNATURE & RAISED SEAL OR DIGITAL SEAL OF THE EVALUATING ENGINEER.

SUBSTANTIATING DATA:

• **Product Evaluation Documents**

Substantiating documentation has been submitted to provide this TER and is summarized in the sections below.

• **Structural Engineering Calculations**

Structural engineering calculations have been prepared which evaluate the product based on comparative and/or rational analysis to qualify the following design criteria:

- Max. allowable lateral & uplift wind pressures certified herein
- Max. allowable sliding forces, uplift forces, & overturning moments (see Unit Reactions from Wind Guide on last page)
- Tie-down configuration and anchor capacity for concrete, aluminum, and steel host substrates (host by others).
- Unit panel wind pressure connection integrity

Calculation summary is included in this TER and appears herein. NOTE: No 33% increase in allowable stress has been used in the design of this product.

LIMITATIONS & CONDITIONS OF USE:

Use of the product(s) listed herein shall be in strict accordance with this TER as noted herein and manufacturer-provided model specifications. Installation shall conform to the minimum standards stated in the referenced building code(s) in addition to the specifications and limitations stated herein. See herein for complete limitations & conditions of use.

OPTIONS:

This evaluation is valid for the AMANA models described herein. The critical unit designs have been determined and used in this evaluation. Any structural changes outside of the design as described herein would void this certification.

UNIT CASING MATERIALS:

26ga galvanized sheet steel ASTM A653 CS cold rolled steels for side covers.
22ga galvanized sheet steel ASTM A653 cold rolled steel for bottom base pan.
20ga galvanized sheet steel ASTM A653 cold rolled steel for top panel.
Removable top & side covers secured with #10-12 sheet metal screws.
Knockouts provided for utility & control connections. Contact Report Holder for further unit construction information.

NOTE: THE GRAPHICAL DEPICTIONS IN THIS REPORT ARE FOR ILLUSTRATIVE PURPOSES ONLY AND MAY DIFFER IN APPEARANCE.

STRUCTURAL PERFORMANCE:

Models referenced herein are subject to the following design limitations:

Maximum Rated Wind Pressures*:
± 119 psf Lateral, 94 psf Uplift

- Required design wind pressures shall be determined according to the guide provided in the Appendix (see last page of this report) or on a site-specific basis in accordance with ASCE 7 and applicable sections of the building code(s) being referenced in accordance with ASD methodology.
- Required design pressures shall be less than or equal to the maximum pressures listed herein.
- *Maximum Rated Wind Pressures indicate the maximum pressures that all units listed herein are approved for. Valid for at-grade and rooftop applications. See limitations herein.
- Valid for use inside and outside the High-Velocity Hurricane Zone (HVHZ).
- Site-specific wind analysis may produce alternate limitations provided maximum rated wind pressures stated herein are not exceeded.

VISIT ECALC.IO/DAIKIN

FOR ENGINEER CERTIFIED ORIGINALS & MORE INFORMATION ABOUT THIS DOCUMENT OR SCAN THE QR CODE TO THE RIGHT >

VISIT ENGINEERINGEXPRESS.COM/STORE FOR ADDITIONAL PLANS, REPORTS & RESOURCES



ORIGINAL SIGNATURE AND RAISED SEAL
OR DIGITAL SEAL REQUIRED TO BE VALID PER CODE:



VALID ONLY FOR ZIP CODE: 00000
VALID ONLY FOR MANUFACTURER'S RECORDS ONLY
NOT VALID FOR PERMIT OR CONSTRUCTION USE
PE0046549 CA-9885

DIGITAL SEAL NOTICE: IF THIS DOCUMENT IS DIGITALLY SIGNED, THIS SHEET IS PART OF A DIGITALLY SIGNED FILE. IT SHALL REMAIN IN DIGITAL FORMAT, SHALL BE VERIFIED BY ELECTRONIC MEANS, & **PRINTED COPIES OF THIS DOCUMENT ARE NOT CONSIDERED SIGNED AND SEALED.** VISIT ECALC.IO/DS FOR MORE INFORMATION.

PRINTED DOCUMENT NOTICE: IF THIS DOCUMENT IS PRINTED & DOES NOT CONTAIN AN ENGINEER'S ORIGINAL SIGNATURE & SEAL, THIS DOCUMENT IS VOID & NOT VALID FOR USE. **PHOTOCOPIES ARE NOT PERMITTED FOR USE.**

MODEL INFORMATION (CONTINUED ON NEXT PAGE)

Cabinet Group	Model Number	Unit Dimensions (in)		
		Width	Depth	Height
A1	A(S,N)X130181	23	23	25.75
B1	A(S,N)X130241	26	26	27.5
B1	A(S,N)X130301	26	26	27.5
B1	A(S,N)X130361	26	26	27.5
C3	A(S,N)X130421	29	29	36.25
C3	A(S,N)X130481	29	29	36.25
C6	A(S,N)X130601	29	29	40
D5	A(S,N)X130611	35.5	35.5	38.25
B1	A(S,N)X140181	26	26	27.5
B1	A(S,N)X140191	26	26	27.5
B1	A(S,N)X140241	26	26	27.5
B2	A(S,N)X140251	26	26	32.5
C2	A(S,N)X140301	29	29	32.5
C2	A(S,N)X140311	29	29	32.5
C2	A(S,N)X140361	29	29	32.5
C2	A(S,N)X140371	29	29	32.5
C3	A(S,N)X140421	29	29	36.25
C3	A(S,N)X140431	29	29	36.25
D1	A(S,N)X140481	35.5	35.5	36.25
D5	A(S,N)X140601	35.5	35.5	38.25
C1	A(S,N)Z140181	29	29	34.5
C1	A(S,N)Z14019	29	29	34.5
C1	A(S,N)Z140241	29	29	34.5
C1	A(S,N)Z14025	29	29	34.5
C5	A(S,N)Z140301	29	29	36.25
D2	A(S,N)Z14031	35.5	35.5	34.63
C5	A(S,N)Z140361	29	29	36.25
D6	A(S,N)Z14037	35.5	35.5	40
D6	A(S,N)Z140421	35.5	35.5	39.75
C5	A(S,N)Z140481	29	29	36.25
D2	A(S,N)Z140491	35.5	35.5	34.5
D2	A(S,N)Z140601	35.5	35.5	34.5
C2	ASX16*181A*	29	29	32
C2	ASX16*241A*	29	29	32
D1	ASX16*301A*	29	29	35.75
D6	ASX16*361A*	29	29	39.5
D3	ASX16*421A*	35.5	35.5	35.75
D6	ASX16*481A*	35.5	35.5	39.5
C2	ASX160181	29	29	32.25

Cabinet Group	Model Number	Unit Dimensions (in)		
		Width	Depth	Height
C2	ASX160241	29	29	32.25
C3	ASX160301	29	29	36.25
C3	ASX160311A	29	29	38.25
C6	ASX160361	29	29	38.25
D1	ASX160371A	35.5	35.5	36.25
D1	ASX160421	35.5	35.5	36.25
D5	ASX160481	35.5	35.5	36.25
D3	ASX160601	35.5	35.5	38.25
D5	ASX160611	35.5	35.5	38.25
C2	ASXC160241	29	29	32.25
C2	ASXC160361	29	29	38.25
D1	ASXC160481	35.5	35.5	36.25
D3	ASXC160601	35.5	35.5	38.25
D6	ASXC180241	35.75	35.75	40
D6	ASXC180361	35.75	35.75	40
D3	ASXC180361	35.5	35.5	38.25
D6	ASXC180481	35.75	35.75	42.25
D3	ASXC180481	35.5	35.5	38.25
D6	ASXC180601	35.75	35.75	42.25
D3	ASXC180601	35.5	35.5	38.25
D6	ASXC702410	35½	35½	39½
D6	ASXC703610	35½	35½	39½
D6	ASXC704810	35½	35½	41½
D6	ASXC706010	35½	35½	41½
B1	ASXH401810	26	26	27
C2	ASXH402410	29	29	32
D6	ASXH403010	35½	35½	39½
D6	ASXH403610	35½	35½	39½
D1	ASXH404210	35½	35½	36½
D1	ASXH404810	35½	35½	36½
D6	ASXH406010	35½	35½	41½
B1	ASXH501810	26	26	27
B2	ASXH502410	29	29	32
D6	ASXH503010	35½	35½	39½
D6	ASXH503610	35½	35½	39½
D1	ASXH504210	35½	35½	36½
D1	ASXH504810	35½	35½	36½
D6	ASXH506010	35½	35½	41½
B1	ASXN401810	26	26	27

Note: The model numbers on this and following page may be followed by up to two (2) alphanumeric characters. Those characters will not affect the structural performance, since they refer to minor/major changes not related to the cabinet structure.

MODEL INFORMATION (CONTINUED FROM PREVIOUS PAGE)

Cabinet Group	Model Number	Unit Dimensions (in)		
		Width	Depth	Height
B2	ASXN402410	26	26	32½
C4	ASXN403010	29	29	39½
D1	ASXN403610	35½	35½	35¼
D6	ASXN404210	35½	35½	39½
D6	ASXN404810	35½	35½	39½
D1	ASXN406010	35½	35½	36½
D4	ASXV902410	35.5	35.5	35
D4	ASXV903610	35.5	35.5	35
D6	ASXV904810	35.5	35.5	42.25
D6	ASXV906101	35.5	35.5	42.25
C5	ASZ160181	29	29	36.38
D2	ASZ160241	35.5	35.5	34.63
D2	ASZ160301	35.5	35.5	34.63
D6	ASZ160361	35.5	35.5	40
C5	ASZ160421	29	29	36.38
D2	ASZ160481	35.5	35.5	34.63
D6	ASZ160601	35.5	35.5	40
C4	ASZC160241	29	29	38.25
D3	ASZC160361	35.5	35.5	38.25
D3	ASZC160481	35.5	35.5	38.25
D3	ASZC160601	35.5	35.5	38.25
D6	ASZC180241	35.5	35.5	40
D3	ASZC180361	35.5	35.5	38.25
D3	ASZC180481	35.5	35.5	38.25
D3	ASZC180601	35.5	35.5	38.25
D6	ASZC702410	35.5	35.5	39.5
D1	ASZC703610	35.5	35.5	35.75
D6	ASZC704810	35.5	35.5	41.63
D6	ASZC706010	35.5	35.5	41.63
C3	ASZH401810	29	29	35.75
C3	ASZH402410	29	29	35.75
C4	ASZH403010	29	29	39.5
D6	ASZH403610	35.5	35.5	39.5
D1	ASZH404210	35.5	35.5	35.75
D1	ASZH404810	35.5	35.5	36.5
D6	ASZH406010	35.5	35.5	41.63
C4	ASZH501810	29	29	39½
D1	ASZH502410	35½	35½	35¼
D6	ASZH503010	35½	35½	39½
D6	ASZH503610	35½	35½	39½
D1	ASZH504210	35½	35½	35¼
D1	ASZH504810	35½	35½	36½
D6	ASZH506010	35½	35½	41½
C3	ASZN401810	29	29	35.75
C3	ASZN402410	29	29	35.75

Cabinet Group	Model Number	Unit Dimensions (in)		
		Width	Depth	Height
C4	ASZN403010	29	29	39.5
D6	ASZN403610	35.5	35.5	39.5
D1	ASZN404210	35.5	35.5	35.75
D1	ASZN404810	35.5	35.5	36.5
D6	ASZN406010	35.5	35.5	41.63
D4	ASZV902410	35.5	35.5	35
D6	ASZV903610	35.5	35.5	42.25
D6	ASZV904810	35.5	35.5	42.25
D6	ASZV906010	35.5	35.5	42.25
D4	AVXC200241	35.5	35.5	38.25
D4	AVXC200361	35.5	35.5	38.25
D6	AVXC200481	35.5	35.5	41.75
D6	AVXC200601	35.5	35.5	41.75
C5	AVZC180241A	29	29	38.25
C5	AVZC180361A	29	29	38.25
D2	AVZC180481A	35.5	35.5	38.25
D2	AVZC180601A	35.5	35.5	38.25
D4	AVZC200241	35.5	35.5	38.25
D6	AVZC200361	35.5	35.5	41.25
D6	AVZC200481	35.5	35.5	41.25
D6	AVZC200601	35.5	35.5	41.25

MODEL INFORMATION NOTES

Unit dimensions listed are unit net dimensions (as opposed to packing/shipping dimensions). Unit net weights shall be between 100 lb and 375 lb, typ. Model information listed herein is based on information provided by the client. See Detail below for definitions of unit dimensions. Unit appearance may vary. Please contact Report Holder for more information.

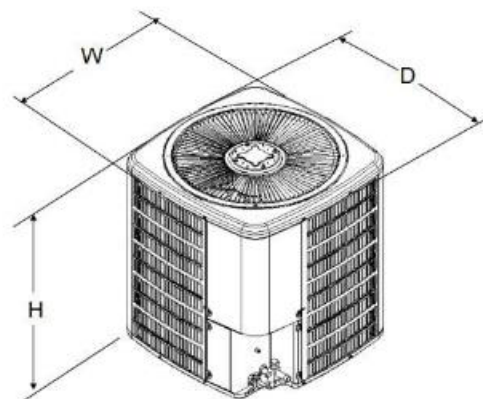

PRODUCT INSTALLATION

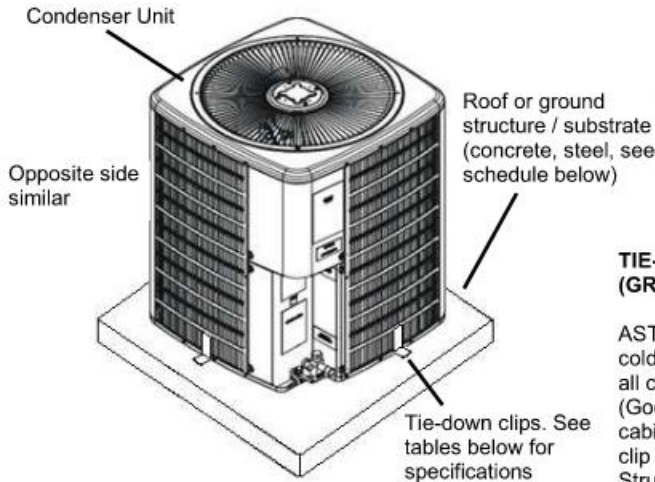

TIE-DOWN CLIP (GROUND APPLICATION)

ASTM A653 G60 galvanized cold rolled steel 0.072" thick for all cabinets tied down at ground (Goodman Bracket); fasten cabinet using (2) anchors per clip from Anchor to Host Structure Schedule Table. Clip integrates into base pan slot.

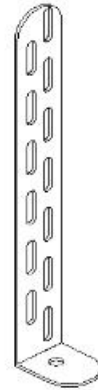

TIE-DOWN CLIP (GROUND AND ROOF APPLICATION)

Miami Tech CUTD 1" wide and any length ASTM A653 galvanized steel 0.07" thick for all cabinets tied down to a roof structure; fasten clip to structure using anchor from Anchor Schedule to Host Structure Table and (2) #10 x 1/2" SS 410 self-drilling screw to fasten clip to unit base pan. See Tie-down Strap & Clip Schedule Table for clip amount. Hurricane kit #DGACUTD36K

Tie-Down Strap & Clip Schedule						
Unit Model	Max Lateral Pressure	Max Uplift Pressure	Strap Req'd?	Qty	Minimum WLL (lbs)	Tie Down Clips Needed
Cabinet A1	50 psf	39 psf	NO	N/A	N/A	4
	106 psf	84 psf	YES	2	300	8
	119 psf	94 psf	YES	2	400	8
Cabinet B1, B2	50 psf	39 psf	NO	N/A	N/A	4
	106 psf	84 psf	YES	2	400	8
	119 psf	94 psf	YES	2	400	8
Cabinet C1 to C5	50 psf	39 psf	NO	N/A	N/A	4
	106 psf	84 psf	YES	2	500	8
	119 psf	94 psf	YES	2	600	8
Cabinet D1 to D6	50 psf	39 psf	NO	N/A	N/A	4
	106 psf	84 psf	YES	2	600	8
	119 psf	94 psf	YES	2	600	8

Anchor to Host Structure Schedule					
Unit Model	Max Lateral Pressure	Max Uplift Pressure	Concrete 3,000 psi	1/8" Min A36 Steel	1/8" Min 6061-T6 Aluminum
All Cabinets A1, B1-2, C1-5, D1-6	50 psf	39 psf	A	N/A	N/A
	119 psf	94 psf	N/A	B	B

Panel Integrity Summary			
Unit Model	Max Lateral Pressure	Max Uplift Pressure	Horizontal Strapping Required
All Cabinets A1, B1-2, C1-5, D1-6	50 psf	39 psf	NONE
	119 psf	94 psf	NONE

Tie-down Strap & Clip Type:

(for roof applications)

Working Load Limit (WLL) is strap's manufacturer - specified per strap. A minimum strap width of 1" is required for all cabinets. Clips heights shall be adequate to fit SMS within base pan height. Verify height on site. Clips should be placed at center on each side and equally spaced, for ground mounted condition. See details on next page for roof mounted condition.

Note: (Vertical Strapping)

- Tie-down straps shall be wrapped around unit and roof stand rail, and shall be tightened using the buckle. Provide two straps per unit.
- Strap material shall be either high strength webbing and shall be compliant for exterior grade use if they contain plastic components, per FBC chapter 26. Or 1" wide 22ga ASTM A653 steel strap secured with (2) #14 SS sms to the bottom of the stand rail.
- For 200 MPH Non-HVHZ, use (2) metal straps, up to 56' MRH Exposure C.

Anchor Types to Host Structure:

- A.** - 1/4" Dewalt ULTRACON SS4 Anchor embedded 3" in 3,000 psi concrete. 2 1/2" from edge minimum.
- B.** - 1/4" -20 UNC SS 316 bolt min. 1/2" from edges with nut and 1" OD washer
- NA.** - No anchors apply.

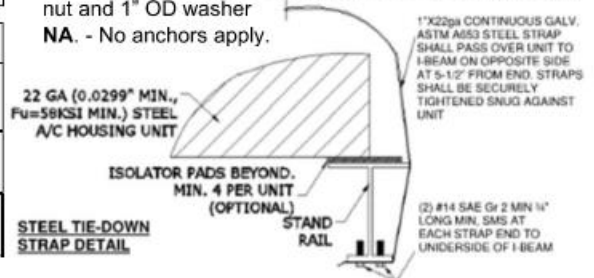

STRAP AND CLIP ROOF INSTALLATION

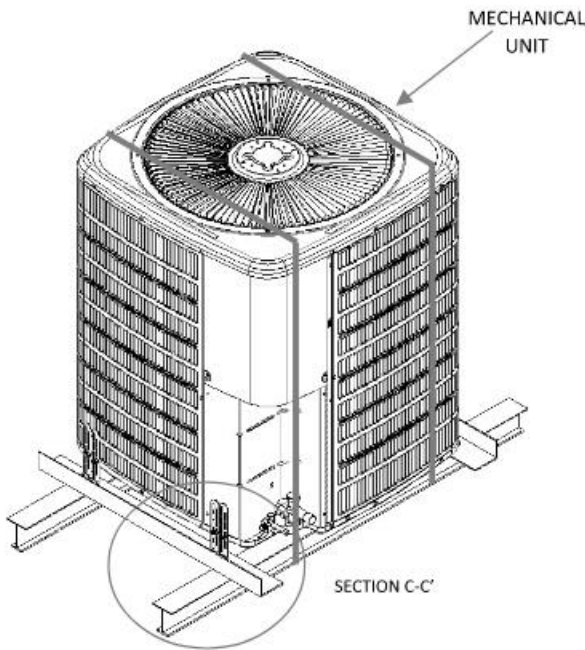

MECHANICAL UNIT ROOF MOUNTED ISOMETRIC

NOTES:

1. 3"X2"X1/8" ALUMINUM ANGLE SHALL BE 6061-T6 AND SHALL OVERHANG 8" MAXIMUM FROM STAND RAIL PER SIDE.
2. CONDENSER SHALL REST ON TOP OF THE STAND RAILS.
3. CLIPS MAY NOT COINCIDE WITH RAIL BELOW, ATTACHED ANGLE USING (2) 1/4" THRUBOLT W/ NUT AND 1.0 OD WASHER.
4. TIE-DOWN CLIPS FOR CABINETS EQUAL OR SMALLER THAN 26" WIDE SHALL BE LOCATED 1" FROM EDGE MIN.

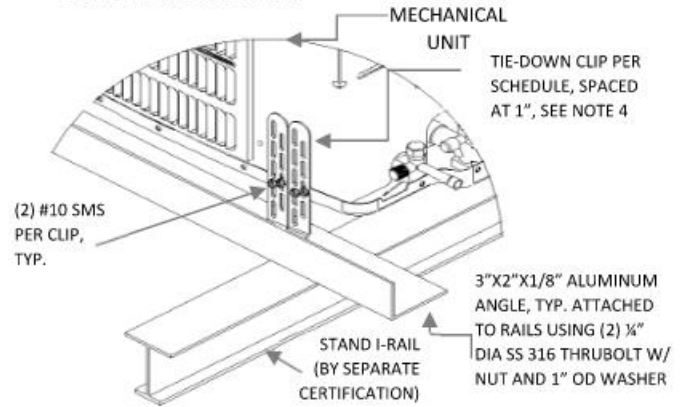

MECHANICAL UNIT TIE-DOWN DETAIL (SECTION C-C')

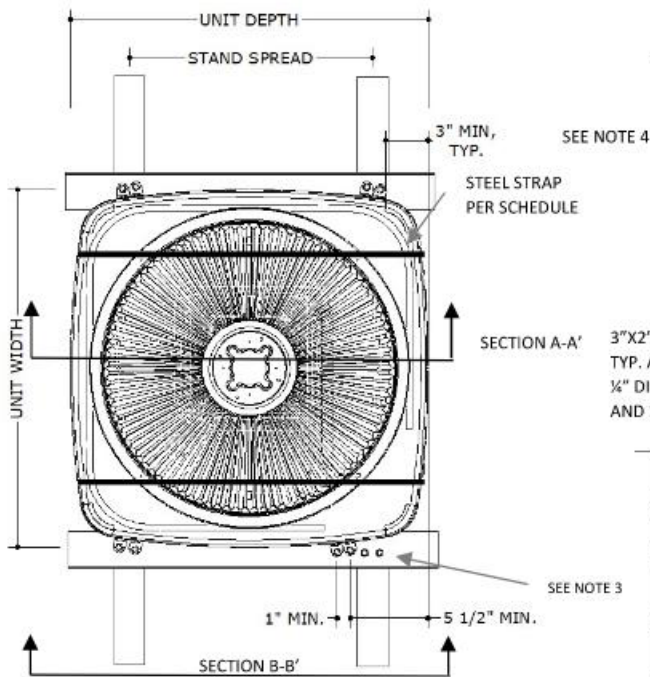

MECHANICAL UNIT ROOF MOUNTED PLAN VIEW

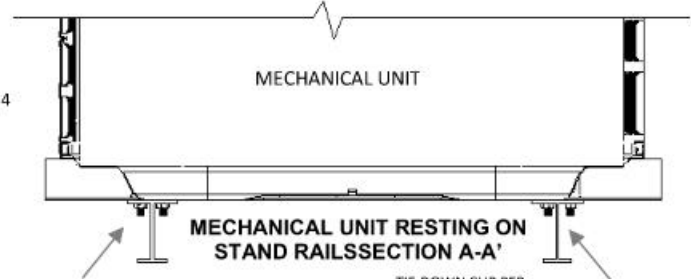

MECHANICAL UNIT RESTING ON STAND RAILS SECTION A-A'

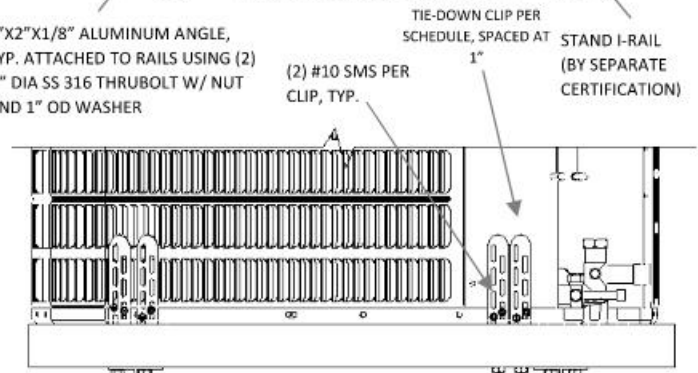

MECHANICAL UNIT RESTING ON STAND RAILS FRONT VIEW (SECTION B-B')

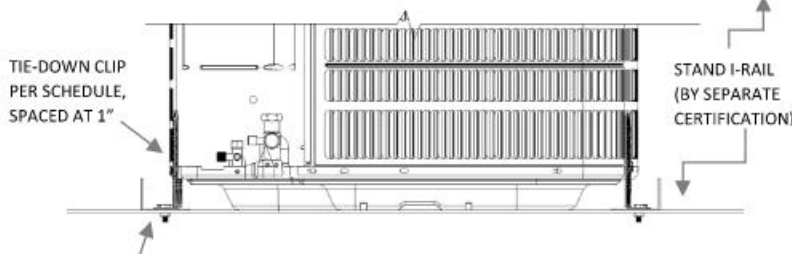

MECHANICAL UNIT RESTING ON STAND RAILS SIDE VIEW

Note: Installers must ensure that screws used to fasten the tie-down clips with the unit base pan do not touch the coil preventing any damage. All pieces and installation parts per Miami Tech Hurricane kit #DGACUTD36K

TERMINOLOGY

The following abbreviations may appear in this report: "Addtl." for "additional", "AHJ" for "Authority Having Jurisdiction", "alum" for "aluminum", "ASCE" for "American Society of Civil Engineers", "ASD" for "Allowable Stress Design", "ASTM" for "American Society for Testing and Materials", "EA." for "each", "E.D." for edge distance, "EDDS" for "extra deep drawing steel", "e.g." for "exempli gratia" or "for example", "equiv." for "equivalent", "FBC" for "Florida Building Code", "FEA" for "Finite Element Analysis", "FLCA" for "Florida Certificate of Authorization", "FS" for "Florida Statutes", "Fu" for "ultimate tensile strength" or "ultimate tensile stress", "Fy" for "yield strength" or "yield stress" "GA" for "gauge", "GR." or "Gr." for "grade", "HVAC" for "heating, ventilation, and air conditioning", "HVHZ" for "High-Velocity Hurricane Zone", "i.e." for "id est" or "in other words", "in" for "inch", "lb" for "pound (force)", "max." for "maximum", "min." for "minimum", "mm" for "millimeter", "NTS" for "not to scale", "O.C." for "on center", "OD" for "outer diameter", "PE" for "Professional Engineer", "qty" for "quantity", "SAE" for "Society of Automotive Engineering", "SMS" for "sheet metal screws", "SS" for "stainless steel", "TER" for "Technical Evaluation Report", "typ." for "typical", "U.N.O." for "unless noted otherwise", "UTS" for "ultimate tensile strength" or "ultimate tensile stress", "WLL" for "working load limit", "w/o" for "without", "YS" for "yield strength" or "yield stress", "#" for "number", "&" for "and", and "Ø" for "diameter". For additional abbreviation/terminology clarifications, please contact this office.

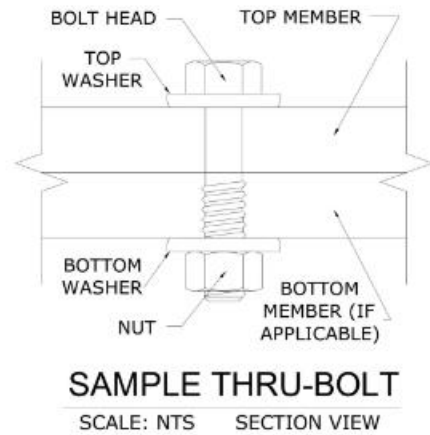

Note: The term "Thru-Bolt" or through bolt, if used herein, refers to a bolt passing through the member(s) in contact and is fastened by a nut at the end opposite the screw head. Nut shall be equivalent to or exceed the strength of the bolt U.N.O. Nut shall be sized to accommodate the same nominal diameter as the bolt U.N.O. See diagram above-right for a sample thru-bolt configuration.

Note: For instances herein which list material specifications as "[material type] or stronger": U.N.O. herein, the term "stronger" refers to a material with a UTS value equal to or greater than the UTS value of the stated material type. Consult appropriate literature for established material UTS values.

Note: Equivalent steel gauge thicknesses as used in this evaluation, U.N.O., are as follows: 22 GA (.030"), 20 GA (.036"), 18 GA (.048"), 16 GA (.060"), 14 GA (.075"), 12 GA (.098").

LIMITATIONS & CONDITIONS OF USE, CONTINUED

Use of this product shall be in strict accordance with this TER as noted herein. The supporting host structure shall be designed to resist all superimposed loads as determined by others on a site-specific basis as may be required by the authority having jurisdiction. Host structure conditions that are not accounted for in this product's respective anchor schedule shall be designed for on a site-specific basis by a registered Professional Engineer. No evaluation is offered for the host supporting structure by use of this document. Adjustment factors noted herein and the applicable building codes must be considered, where applicable. Product components shall be of the material(s) specified in the manufacturer-provided product specifications. All supporting components which are permanently installed shall be protected against corrosion, contamination, and other such damage at all times. All fasteners and anchors shall be installed in accordance with the applicable provisions specified herein in addition to the anchor/fastener manufacturers' published installation instructions. Fasteners must penetrate the supporting members such that the full length of the threaded portion is embedded within the main member.

All of the wind-resisting exterior panels (with accompanying retrofits) individually meet or exceed their capacity to resist the design wind loads as stated in the calculations as required by the codes and standards stated herein. Due to the indeterminate nature of these units, distortion, deflection, and material deformation cannot be accurately evaluated, but with the diaphragm action of external components and internal stiffeners, the base unit (with accompanying retrofits stated herein as applicable) has the capacity to withstand the design wind loads without detaching from the unit and becoming flying debris.

Survivability: Evaluation reports are valid for a newly installed unit and do not include certification of the product beyond a design event or if impacted by any debris. Inspections shall be implemented annually by the end user and after every named storm. All fasteners and cabinet components are to be verified, and all damaged, loose, corroded and/or broken fasteners and cabinet components shall be replaced to ensure structural integrity against hurricane wind forces. Contact this office for any reevaluation needs or as designated by the Authority Having Jurisdiction.

Durability: Components or component assemblies shall not deteriorate, crack, fail, or lose functionality due to galvanic corrosion or weathering. All supporting components which are permanently installed shall be protected against corrosion, contamination, and other such damage at all times. Each component or component assembly shall be supported and oriented in its intended installation position. All exposed plastic components shall be certified to resist sunlight exposure as specified by ASTM B117, or ASTM G155 in Broward or Miami Dade counties.

Extent of Certification: Certification pertains to the overall structural integrity of the unit components listed within the evaluation as required by code, subject to the limitations and criteria stated herein. Operability during or after a design event is not included in this certification. Water infiltration is outside the bounds of this certification. No other certifications are intended other than as described herein. This evaluation alone does not offer any evaluation for large missile impact debris or cyclic wind requirements unless specifically stated herein.

Proj. #	Remarks	By	Checked	Date	Proj. #	Remarks	By	Checked	Date
16-3146.3	Initial Issue	LAO	FLB	7/6/16	20-34275	Add Model #'s	MD	RS	7/12/22
20-34275	Update to 2020 FBC	CCB	RWN	12/29/20	20-34275	Add Model #'s & Template Update	MRT	EPR	3/14/23

APPENDIX A: DESIGN WIND PRESSURE GUIDE

Max. Ult. Wind Speed (V _{ult})	Max. MRH (Roof Height)	Exposure Category	Required Design Wind Pressures (ASD)	
			Lateral Pressure	Uplift Pressure
140 mph	At-Grade (0 ft)	C	± 26 psf	0* psf
		D	± 31 psf	0* psf
	100 ft	C	± 63 psf	50 psf
		D	± 71 psf	56 psf
	200 ft	C	± 72 psf	57 psf
		D	± 80 psf	63 psf
175 mph	At-Grade (0 ft)	C	± 40 psf	0* psf
		D	± 49 psf	0* psf
	100 ft	C	± 98 psf	77 psf
		D	± 111 psf	87 psf
	200 ft	C	± 113 psf	89 psf
		D	± 124 psf	98 psf
186 mph	At-Grade (0 ft)	C	± 46 psf	0* psf
		D	± 54 psf	0* psf
	100 ft	C	± 111 psf	87 psf
		D	± 125 psf	99 psf
	200 ft	C	± 127 psf	100 psf
		D	± 140 psf	111 psf

100-psf

Note: Any table values with the format shown left, if present, indicate design wind pressures and site conditions that are **not approved for use** by this evaluation. Seek additional engineering or contact this firm for design solutions.

DIRECTIVE: This design pressure guide is for reference only and shall be approved for use by the Authority Having Jurisdiction (AHJ). If the design pressures listed in this guide are not used, required design pressures shall be calculated separately. For site-specific scenarios classified as Exposure Category B, the required design pressures stated for Exposure Category C in the above guide shall be used or design pressures shall be calculated separately. For heights and parameters beyond the parameters listed in this guide, visit our Online Calculator via the website link (<https://ecalcalc.io/forces>) or QR Code below, or obtain calculations separately by others.

The required ASD design pressures listed in this guide were calculated per the table's listed corresponding site conditions. The project design professional or permitting contractor shall verify that the site-specific conditions are equal to or less than the approved design parameters listed in the guide. Per the note below table: any values shown as "~~XX-psf~~", indicate wind pressures and corresponding site conditions that are **not valid for use** with this evaluation (exceeds the max. rated pressures).

*Note: Per the codes and standards referenced herein, uplift is not required for mechanical equipment at-grade. If uplift at-grade is required by the AHJ, contact this firm for a site-specific evaluation.

At-Grade (0 ft MRH) Required Design Pressures:

- o ASCE 7 "Design Wind Loads: Other Structures"
- o Structure Shape = Square, flat terrain
- o Height of structure (unit + stand or curb, if used) = 6 ft max.
- o Width of unit = 1 ft min., Depth of unit = 11 in min.

Rooftop (>15 ft MRH) Required Design Pressures:

- o ASCE 7 "Design Wind Loads: Other Structures: Rooftop Structures and Equipment for Buildings"
- o Structure Shape = Square, flat terrain
- o z = up to 7 ft, where z = height of stand or curb + ½ unit height
- o Lateral GC_r = 1.90; Uplift GC_r = 1.50

VISIT [ECALC.IO/FORCES](https://ecalcalc.io/forces)

FOR DESIGN AID CALCULATORS AND RESOURCES RELATED TO THIS TER & GUIDES HEREIN, OR SCAN THE QR CODE RIGHT >



UNIT REACTIONS FROM WIND GUIDE

DIRECTIVE: This guide is intended for use by a design professional. Design parameters shall abide all specifications and limitations stated in this report. Design professional shall consider all forces, including seismic and snow loads, per the governing building code. Unit reactions obtained from this guide shall be verified by a registered Professional Engineer. Reactions are applicable for unit-to-host connections only. Sample calculations are provided below.

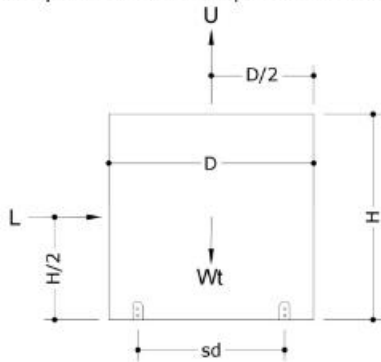

Design Parameters:

- Lateral Wind Pressure, P_{lat}
- Unit Height, H
- Unit Width, W
- Support Spacing across Depth, sd
- Uplift Wind Pressure, P_{up}
- Unit Depth, D
- Unit Weight, Wt
- Support Spacing across Width, sw

Unit Reaction Equations:

Long Side (Width x Height):

- Sliding Force, L = P_{lat} x W x H
- Uplift Force, U = P_{up} x W x D
- Total Tension per Long Side = (L x H/2 + U x sd/2 - Wt x 0.6 x sd/2) / sd

Short Side (Depth x Height):

- Sliding Force, L = P_{lat} x D x H
- Uplift Force, U = P_{up} x W x D
- Total Tension per Short Side = (L x H/2 + U x sw/2 - Wt x 0.6 x sw/2) / sw

Example: A (48" W x 36" D x 42" H), 250 lb net weight unit at wind pressures of 120 psf lateral and 95 psf uplift, on a 24" wide roof stand, shall have the following unit reactions:

Long Side (Width x Height):

1. Sliding Force, L = P_{lat} x W x H = (120 psf) x (48 in) x (42 in) x (1 in² / 144 ft²) = **1680 lb**
2. Uplift Force, U = P_{up} x W x D = (95 psf) x (48 in) x (36 in) x (1 in² / 144 ft²) = **1140 lb**
3. Total Tension per Long Side = (L x H/2 + U x sd/2 - Wt x 0.6 x sd/2) / sd = ((1680 lb x 42/2 in) + (1140 lb x 24/2 in) - (250 lb x 0.6 x 24/2 in)) / 24 in = **1965 lb**

Short Side (Depth x Height):

1. Sliding Force, L = P_{lat} x D x H = (120 psf) x (36 in) x (42 in) x (1 in² / 144 ft²) = **1260 lb**
2. Uplift Force, U = P_{up} x W x D = (95 psf) x (48 in) x (36 in) x (1 in² / 144 ft²) = **1140 lb**
3. Total Tension per Short Side = (L x H/2 + U x sw/2 - Wt x 0.6 x sw/2) / sw = ((1260 lb x 42/2 in) + (1140 lb x 48/2 in) - (250 lb x 0.6 x 48/2 in)) / 48 in = **1046 lb**

IN ALL CONDITIONS IT IS THE RESPONSIBILITY OF THE PERMIT HOLDER TO ENSURE THE HOST STRUCTURE IS CAPABLE OF WITHSTANDING THE RATED GRAVITY, LATERAL, AND UPLIFT FORCES BY SITE-SPECIFIC DESIGN. NO WARRANTY OF ANY KIND, EXPRESSED OR IMPLIED, IS OFFERED BY ENGINEERING EXPRESS AS TO THE INTEGRITY OF THE HOST STRUCTURE TO CARRY DESIGN FORCE LOADS INCURRED BY THIS UNIT.