

High Wind Tie Down Kit

INSTALLATION INSTRUCTIONS

For Anchoring (*)SA1 Series Air Conditioners and (*)SH1 Series Heat Pumps on a Roof (1.5 to 5 Ton Units)

IMPORTANT SAFETY INFORMATION

INSTALLER: Please read all instructions before servicing this equipment. Pay attention to all safety warnings and any other special notes highlighted in the manual. Safety markings are used frequently throughout this manual to designate a degree or level of seriousness and should not be ignored. **WARNING** indicates a potentially hazardous situation that if not avoided, could result in personal injury or death.

WARNING:

ELECTRICAL SHOCK, FIRE OR EXPLOSION HAZARD

Failure to follow safety warnings exactly could result in serious injury or property damage.

Improper servicing could result in dangerous operation, serious injury, death or property damage.

- Before servicing, disconnect all electrical power to the unit.
- When servicing controls, label all wires prior to disconnecting. Reconnect wires correctly.
- This unit may have more than one power supply.
- Verify proper operation after servicing.

WARNING:

The safety information listed below must be followed during the installation, service, and operation of this unit. Unqualified individuals should not attempt to interpret these instructions or install this equipment. Failure to follow safety recommendations could result in possible damage to the equipment, serious personal injury or death.

- Follow all precautions in the literature, on tags and labels provided with the equipment. Read and thoroughly understand the instructions provided with the equipment prior to performing the installation and operational checkout of the equipment.
- Unless noted otherwise in these instructions, only factory authorized parts or accessory kits may be used with this product. Improper installation, service, adjustment, or maintenance may cause fire, electrical shock or other hazardous conditions which may result in personal injury or property damage.

- Use caution when handling this equipment or removing components. Personal injury can occur from sharp metal edges present in all sheet metal constructed equipment.

ABOUT THE KIT

Miami Tech Kit (Small footprint): NCUTD30KR

Miami Tech Kit (Large footprint): NCUTD38KR

This high wind kit is used to anchor split-system air conditioners and heat pumps to adequately designed roof stands. This system is designed to meet the latest requirements of Florida Building Code when installed according to these instructions and the supplied Technical Evaluation Report.

INSTALLATION OF THE ANCHOR KIT ON SPLIT-SYSTEM AC/HP UNITS:

It is recommended that this kit be installed on the unit prior to connecting refrigerant lines and electrical wiring. It may be installed later if necessary.

1. Position the unit in the center of the roof stand rails.
 - **NOTE:** 18" center-to-center span for small footprint, 24" center-to-center span for large footprint.
 - **NOTE:** For conditions with stand width greater than unit width, use Miami-Tech support angles (part #AS14CABBXX) per NOA#17-1218.02 or site-specific engineering is required. Refer to the installation instructions provided in the kit.
2. Dry-fit two 3"x3" aluminum angles perpendicular to the stand rails on either side of the unit, with the vertical sides away from the unit.
3. Temporarily place the included brackets to confirm correct placement of the angles, then clamp the angles to the roof stand rails.
4. Drill two clearance holes per rail and bracket intersection (8 total), then bolt the frame to the stand using included bolts, top and bottom washers, and lock nuts.
5. Place and clamp the two remaining angles parallel to the stand rails (with the vertical side closest to the unit).
5. Temporarily place the brackets to confirm their position. Reposition the angles if necessary.
6. Drill one clearance hole per angle/angle intersection (4 total), then attach using the included bolts, top and bottom washers, and lock nuts.
7. Place and secure each bracket according to the ANCHOR LAYOUT to the unit using (4) of the included #10-16 self-drilling screws.
 - **NOTE:** Install the screws at the top of the available slots.
 - **NOTE:** Verify the bottom of the bracket remains flush with the aluminum angles.
8. Drill one clearance hole per bracket/angle connection (12 total), then attach the brackets using the included bolts, top and bottom washers, and lock nuts.
9. If installing a large footprint unit (approximately 32" wide), install two self-drilling screws through the top pan and into each panel (8 total).



D3117280
(NEW)

EVALUATION SUBJECT: **PANELIZED SPLIT SYSTEMS**

TER-19-8163.1

REPORT HOLDER:

NORTEK GLOBAL HVAC
8000 PHOENIX PARKWAY
O'FALLON, MO 63368 USA
(800) 422-4328 | NORTEK.COM



Florida Building Code Sixth Edition (2017)



SCOPE OF EVALUATION (compliance with the following codes):

THIS IS A STRUCTURAL (WIND) PERFORMANCE EVALUATION ONLY. NO ELECTRICAL OR TEMPERATURE PERFORMANCE RATINGS OR CERTIFICATIONS ARE OFFERED OR IMPLIED HEREIN.

This Product Evaluation Report is being issued in accordance with the requirements of the Florida Building Code Sixth Edition (2017) per FBC Section 104.11.1, FMC 301.15, FBC Building Ch. 16, ASCE-7-10, FBC Existing Building sections 707.1, 707.2, FBC Building 1522.2, and FBC Residential M1202.1, M1301.1, FS 471.025, including Broward County Administrative Provisions 107.3.4. The product noted on this report has been tested and/or evaluated as summarized herein.

IN ACCORDANCE WITH THESE CODES EACH OF THESE REPORTS MUST BEAR THE ORIGINAL SIGNATURE & RAISED SEAL OF THE EVALUATING ENGINEER.

SUBSTANTIATING DATA:

• **Product Evaluation Documents**

Substantiating documentation has been submitted to provide this TER and is summarized in the sections below.

• **Structural Engineering Calculations**

Structural engineering calculations have been prepared which evaluate the product based on comparative and/or rational analysis to qualify the following design criteria:

- Maximum allowable unit panel wind pressure connection integrity
- Maximum allowable uplift, sliding, & overturning moment for ground and roof applications

Calculation summary is included in this TER and appears below.

NOTE: No 33% increase in allowable stress has been used in the design of this product.

INSTALLATION:

The product(s) listed above shall be installed in strict compliance with this TER & manufacturer-provided model specifications.

The product components shall be of the material specified in the manufacturer-provided product specifications. All screws must be installed in accordance with the applicable provisions & anchor manufacturer's published installation instructions.

LIMITATIONS & CONDITIONS OF USE:

Use of this product shall be in strict accordance with this TER as noted herein. See final page for complete limitations and conditions of use.

INSTALLATION:

Shall follow manufacturer specifications as well as information provided herein.

FINISH:

Baked enamel, casing color gray.

NOTE: THE GRAPHICAL DEPICTIONS IN THIS REPORT ARE FOR ILLUSTRATIVE PURPOSES ONLY AND MAY DIFFER IN APPEARANCE.

UNIT CASING MATERIAL:

20ga galvanized steel sheet equivalent to ASTM A653 EDDS cold rolled steel for removable top panel. 30% Talc reinforced polypropylene for base pan. 24ga galvanized steel sheet ASTM A653 for side protector panels, secured with #12-14 C1016-C1024 at base pan and #10-16 C1016-C1024 sheet metal screws into top.

OPTIONS:

This evaluation is valid for all PANELIZED models that appear in the table located on the final page of this report.

STRUCTURAL PERFORMANCE:

Models referenced herein are subject to the following design limitations:

ASCE-710 Exposure Categories C

Up to and including 175mph (Vult) for up to See Page 2 MRH**, HVHZ***

Up to 200mph (Vult). Non-HVHZ*** Ground EXP D

Ground or Roof Application per installation instructions

Mean Roof Height *High Velocity Hurricane Zone

Maximum Rated Wind Pressure:

118psf Lateral 93psf Uplift (ASD)

ORIGINAL SIGNATURE AND RAISED SEAL
OR DIGITAL SEAL REQUIRED TO BE VALID PER CODE:

P.E. SEAL REQUIRED

NOT FOR USE

February 10, 2020

Frank L. Bennardo, P.E., SECB Signed by If Checked:

ENGINEERING EXPRESS®

Gordon DiBattisto, PE

FL PE #0046549

FLCA #9885

FL PE #82328

NOTICE: IF THIS PAGE DOES NOT CONTAIN AN ORIGINAL SIGNATURE & ENGINEER SEAL:
IF THERE IS A DIGITAL SIGNATURE ON PAGE 1, THIS DOCUMENT IS PART OF A DIGITALLY SIGNED FILE, SHALL REMAIN IN DIGITAL FORMAT & PRINTED COPIES OF THIS DOCUMENT ARE NOT CONSIDERED SIGNED AND SEALED. IF THERE IS NO DIGITAL SIGNATURE ON PAGE 1 OR THIS PAGE DOES NOT CONTAIN AN ENGINEER'S ORIGINAL SIGNATURE & SEAL, THIS DOCUMENT IS A COPY/DRAFT.

VISIT ECALC.IO/NORTEK

FOR ENGINEER CERTIFIED ORIGINALS
& MORE INFORMATION ABOUT THIS DOCUMENT
OR SCAN THE QR CODE TO THE RIGHT >

VISIT ENGINEERINGEXPRESS.COM/STRUCTALL
FOR ADDITIONAL PLANS, REPORTS & RESOURCES



Copyright © Engineering Express® . All Rights Reserved

SECTION 2 PRODUCT INSTALLATION

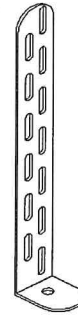
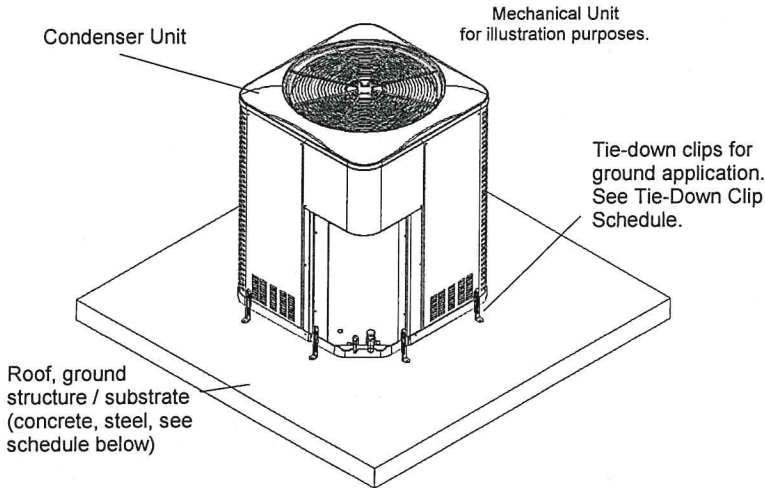

TIE-DOWN CLIP (GROUND APPLICATION)

Miami Tech CUTD 1" wide and 8" long min ASTM A653 galvanized steel 0.07" thick for all cabinets tied down at ground; fasten clip to host structure using anchor from Anchor Schedule to Host Structure Table and (4) #10-16 x 1/2" SS316 min self-drilling screw to fasten clip to unit. MIAMI-TECH KIT #NCUTD8KG

ANCHOR LAYOUT AT GRADE LEVEL CABINET A

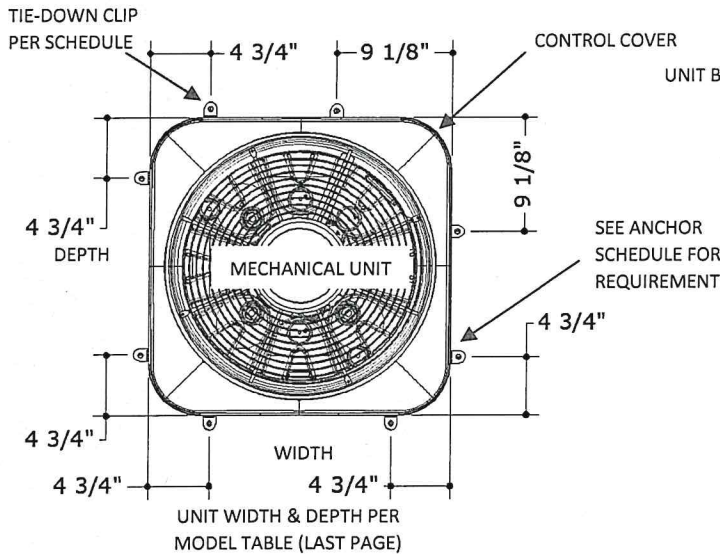

MECHANICAL UNIT

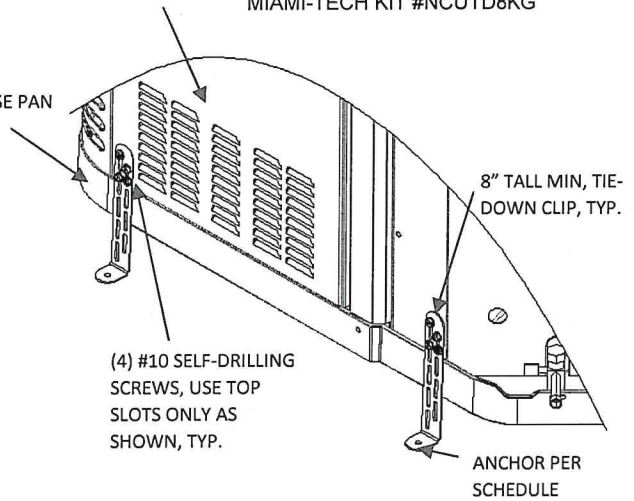

TIE-DOWN CLIP DETAIL

ANCHOR LAYOUT AT GRADE LEVEL CABINET B

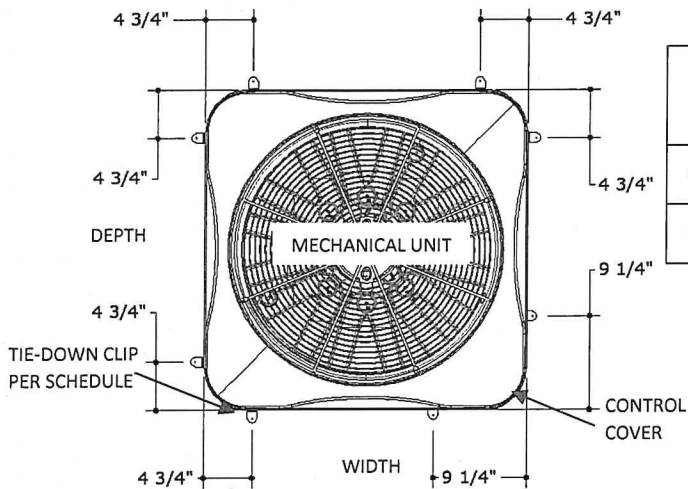

ANCHOR SCHEDULE TO HOST STRUCTURE

Cabinet	Pressure Lateral / Uplift (PSF)		Mean Roof Height (feet)	Anchor Type			Tie down Clips	
				Concrete 3,000 Psi	1/8" Min A36 Steel	1/8" Min 6061-T6 Aluminum	Ground (Pcs)	Roof (Pcs)
Cabinet A	Ground		200	A	NA	NA	8	-
	118	93	200	NA	B	B	-	12
Cabinet B	Ground		200	A	NA	NA	8	-
	118	93	200	NA	B	B	-	12

Anchor Types to Host Structure:

- A. - 1/4" HILTI KBV Expansion Anchor embedded 2" in 4,000 psi concrete. 4" from edge minimum.
- B. - 1/4" UNC SS 410 bolt minimum 1/2" from edges with nut and washer specified for installation at roof level.
- NA. - NOT APPLICABLE

IN ALL CONDITIONS IT IS THE RESPONSIBILITY OF THE PERMIT HOLDER TO ENSURE THE HOST STRUCTURE IS CAPABLE OF WITHSTANDING THE RATED GRAVITY, LATERAL, AND UPLIFT FORCES BY SITE-SPECIFIC DESIGN. NO WARRANTY OF ANY KIND, EXPRESSED OR IMPLIED, IS OFFERED BY ENGINEERING EXPRESS AS TO THE INTEGRITY OF THE HOST STRUCTURE TO CARRY DESIGN FORCE LOADS INCURRED BY THIS UNIT.

**ANCHOR LAYOUT AT ROOF LEVEL CABINET A
MIAMI-TECH KIT #NCUTD30KR**

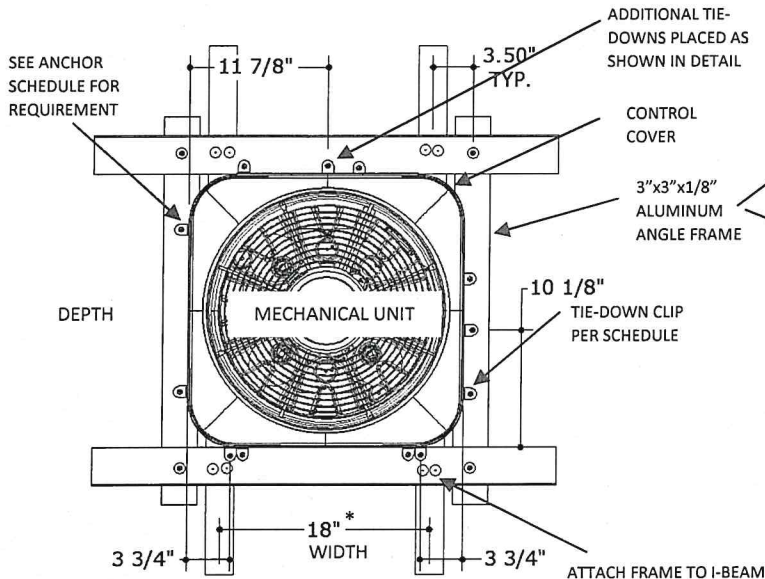

**ANCHOR LAYOUT AT ROOF LEVEL CABINET B
MIAMI-TECH KIT #NCUTD38KR**

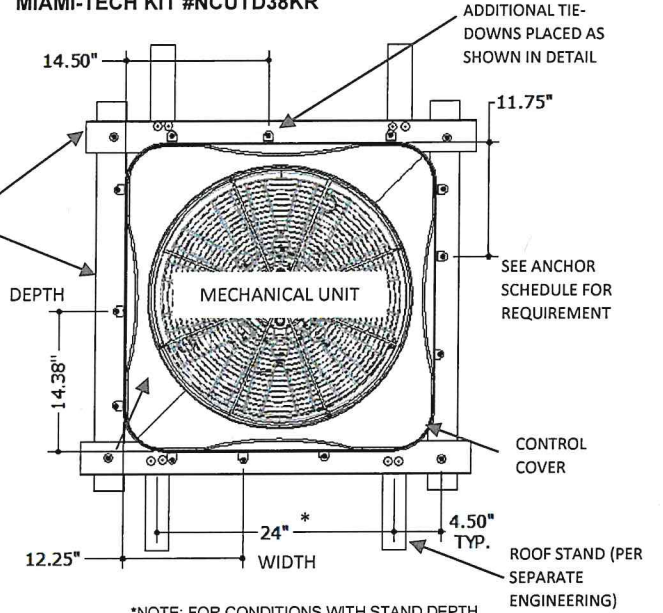

MECHANICAL UNIT ROOF MOUNTED

ADD (2) #10 SCREW TO CABINET B FOR ROOF MOUNT OPTION

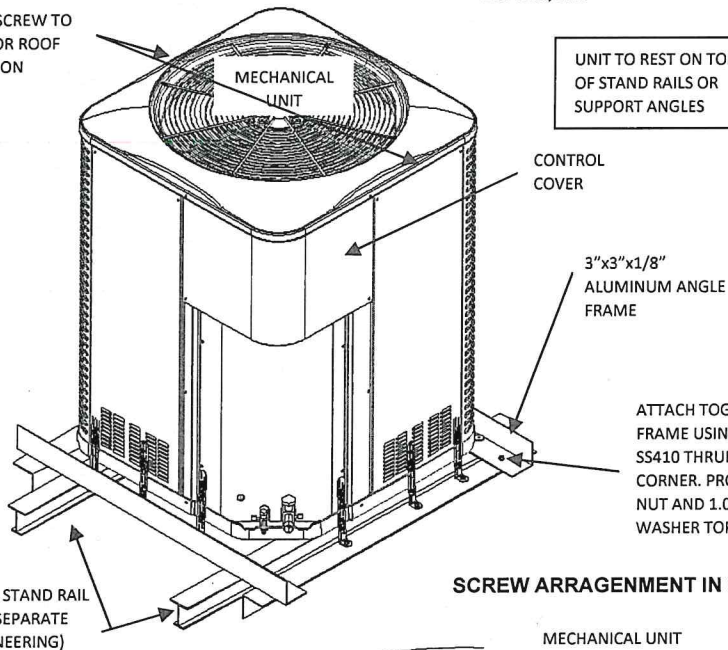

FRAME TYPICAL CONNECTIONS

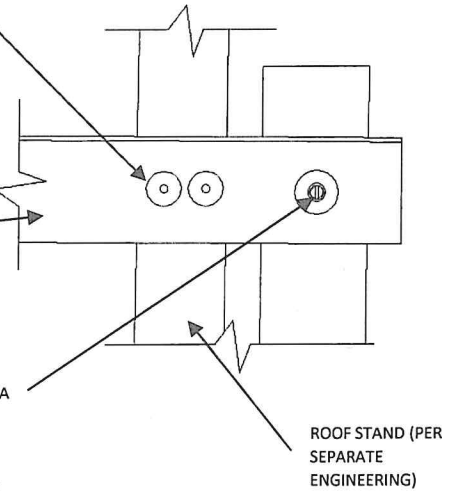

SCREW ARRANGEMENT IN CLIPS

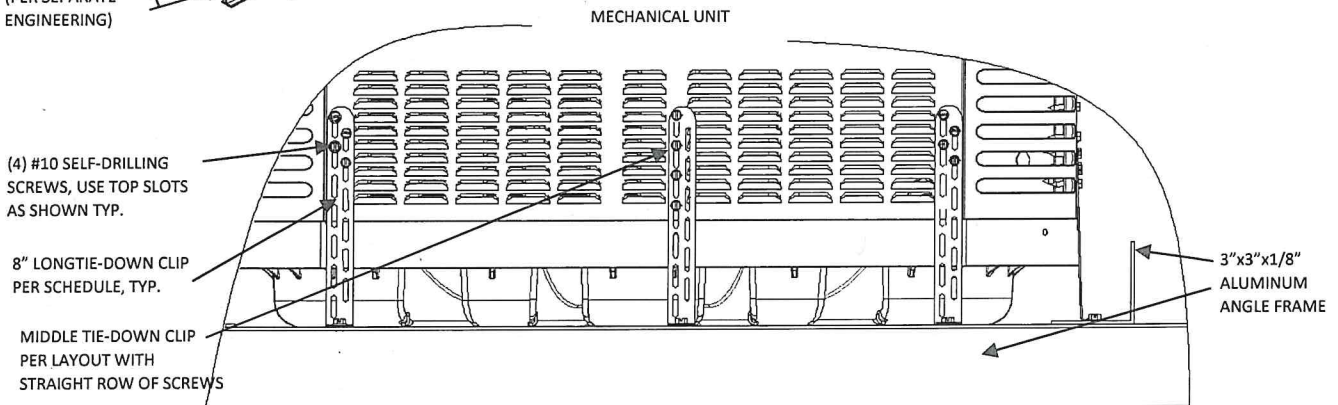

SECTION 3 SUPPORTING CALCULATIONS & SUMMARY

FORCES SUMMARY

Cabinet	Ground or Roof	Mean Roof Height (feet)	Lateral Pressure (Psf)	Uplift Pressure (Psf)	Side Force (lbs)	Side Overturn (lbs-in)	Anchor Side Tension (lbs)	Uplift Force (lbs)
Cabinet A	Ground		66.3	53.8	399.2	7285.3	410.4	210.8
	Roof	200	118.3	93.4	712.0	12994.3	263.7	365.8
Cabinet B	Ground		66.3	53.8	661.6	14968.5	689.3	376.6
	Roof	200	118.3	93.4	1180.0	26698.3	275.1	653.7

PANEL INTEGRITY SUMMARY

Cabinet	Wind Pressure Lateral (Uplift)	Mean Roof Height (feet)	Additional Reinforcement Beyond Original Manufactured Cabinet	Cabinet	Wind Pressure Lateral (Uplift)	Mean Roof Height (feet)	Additional Reinforcement Beyond Original Manufactured Cabinet
Cabinet A	Ground		Tie-down Clips shown in detail page	Cabinet B	Ground		Tie-down Clips shown in detail page
	118 (93)	200	Tie-down Clips shown in detail page		118 (93)	200	Tie-down Clips shown in detail page plus (2) screw at top panel

Note:

1. Calculations performed according to the information provided by the client.
2. Screw quantities were checked to reinforce unit panels as needed. Validate that the screw joins the panel with the supporting element.
3. Additional screw shall be at least #10 x 1/2" long Gr 2.
4. Installer shall insulate dissimilar metals if needed.
5. See screw location on detail page.

ELEVATIONS & DIMENSIONS

Model Number	Weight (lbs)	Height (in)	Width (in)	Depth (in)	Cabinet
*SA1BD4M1SN18K	129	24.5	23.75	23.75	A
*SA1BD4M1SN24K	126	24.5	23.75	23.75	A
*SA1BD4M1SN30K	133	28.5	23.75	23.75	A
*SA1BD4M1SN36K	140	28.5	23.75	23.75	A
*SA1BD4M1SN42K	195	29.25	31.75	31.75	B
*SA1BD4M1SN48K	197	29.25	31.75	31.75	B
*SA1BD4M1SN60K	217	33.25	31.75	31.75	B
*SA1BE4M1RN18K	129	32.5	23.75	23.75	A
*SA1BE4M1RN24K	145	32.5	23.75	23.75	A
*SA1BE4M1RN30K	165	29.25	31.75	31.75	B

Model Number	Weight (lbs)	Height (in)	Width (in)	Depth (in)	Cabinet
*SA1BE4M1SN18K	143	28.5	23.75	23.75	A
*SA1BE4M1SN24K	151	32.5	23.75	23.75	A
*SA1BE4M1SN30K	160	29.25	31.75	31.75	B
*SA1BE4M1SN36K	183	37.25	31.75	31.75	B
*SA1BE4M1SN42K	213	41.25	31.75	31.75	B
*SA1BE4M1SN48K	215	41.25	31.75	31.75	B
*SA1BE4M1SN60K	251	45.25	31.75	31.75	B
*SA1BF4M1SN24K	145	36.5	23.75	23.75	A
*SA1BF4M1SN30K	164	29.25	31.75	31.75	B
*SA1BF4M1SN36K	233	41.25	31.75	31.75	B

Model Number	Weight (lbs)	Height (in)	Width (in)	Depth (in)	Cabinet
*SA1BF4M1SN42K	230	45.25	31.75	31.75	B
*SA1BF4M1SN48K	226	45.25	31.75	31.75	B
*SA1BF4M2SN24K	133	36.5	23.75	23.75	A
*SA1BF4M2SN36K	205	37.25	31.75	31.75	B
*SA1BF4M2SN48K	232	41.25	31.75	31.75	B
*SA1BF4M2SN60K	251	45.25	31.75	31.75	B
*SA1BG4MVRN24K	166	36.5	23.75	23.75	A
*SA1BG4MVRN36K	218	37.25	31.75	31.75	B
*SA1BG4MVRN48K	246	45.25	31.75	31.75	B
*SA1BG4MVRN60K	261	45.25	31.75	31.75	B
*SA1QD4M1RN24K	138	28.5	23.75	23.75	A
*SA1QD4M1RN30K	141	28.5	23.75	23.75	A
*SA1QD4M1RN36K	149	36.5	23.75	23.75	A
*SA1QD4M1SN24K	134	24.5	23.75	23.75	A
*SA1QD4M1SN30K	137	28.5	23.75	23.75	A
*SA1QD4M1SN36K	145	28.5	23.75	23.75	A
*SA1QD4M1SN42K	156	29.25	31.75	31.75	B
*SA1QD4M1SN48K	188	29.25	31.75	31.75	B
*SA1QD4M1SN60K	198	33.25	31.75	31.75	B
*SA1QE4M1RN24K	148	32.5	23.75	23.75	A
*SA1QE4M1RN30K	169	29.25	31.75	31.75	B
*SA1QE4M1SN24K	151	32.5	23.75	23.75	A
*SA1QE4M1SN30K	160	29.25	31.75	31.75	B
*SA1QE4M1SN36K	183	37.25	31.75	31.75	B
*SA1QE4M1SN42K	213	41.25	31.75	31.75	B
*SA1QE4M1SN48K	215	41.25	31.75	31.75	B
*SA1QE4M1SN60K	251	45.25	31.75	31.75	B
*SA1QD4M1RN24KA	136	28.50	23.75	23.75	A
*SA1QD4M1RN30KA	140	28.50	23.75	23.75	A
*SA1QD4M1RN36KA	143	36.50	23.75	23.75	A
*SH1BE4M1SP60KA	236	45.25	31.75	31.75	B

Model Number	Weight (lbs)	Height (in)	Width (in)	Depth (in)	Cabinet
*SH1BE4M1SP18K	185	33.25	31.75	31.75	B
*SH1BE4M1SP24K	192	33.25	31.75	31.75	B
*SH1BE4M1SP30K	208	41.25	31.75	31.75	B
*SH1BE4M1SP36K	212	45.25	31.75	31.75	B
*SH1BE4M1SP42K	232	45.25	31.75	31.75	B
*SH1BE4M1SP48K	234	45.25	31.75	31.75	B
*SH1BE4M1SP60K	236	45.25	31.75	31.75	B
*SH1BF4M1SP24K	185	37.25	31.75	31.75	B
*SH1BF4M1SP30K	193	37.25	31.75	31.75	B
*SH1BF4M1SP36K	201	45.25	31.75	31.75	B
*SH1BF4M1SP42K	236	45.25	31.75	31.75	B
*SH1BF4M1SP48K	241	45.25	31.75	31.75	B
*SH1BF4M2SX24K	211	37.25	31.75	31.75	B
*SH1BF4M2SX36K	227	45.25	31.75	31.75	B
*SH1BF4M2SX48K	261	45.25	31.75	31.75	B
*SH1BF4M2SX60K	249	45.25	31.75	31.75	B
*SH1BG4CVRX24K	228	37.25	31.75	31.75	B
*SH1BG4CVRX36K	297	41.25	31.75	31.75	B
*SH1BG4CVRX48K	291	41.25	31.75	31.75	B
*SH1BG4CVRX60K	291	45.25	31.75	31.75	B
*SH1QE4M1SP24K	154	33.25	31.75	31.75	B
*SH1QE4M1SP30K	161	41.25	31.75	31.75	B
*SH1QE4M1SP36K	183	45.25	31.75	31.75	B
*SH1QE4M1SP42K	232	45.25	31.75	31.75	B
*SH1QE4M1SP48K	234	45.25	31.75	31.75	B

Note:
(*) in table represents a single brand designator.

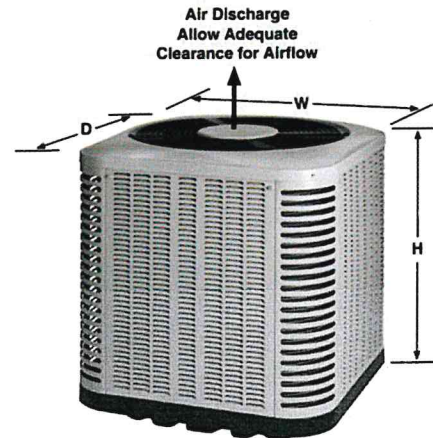

LIMITATIONS & CONDITIONS OF USE:

Use of this product shall be in strict accordance with this TER as noted herein. The supporting host structure shall be designed to resist all superimposed loads as determined by others on a site-specific basis as may be required by the Authority Having Jurisdiction. Host structure conditions which are not accounted for in this product's respective anchor schedule shall be designed for on a site-specific basis by a registered professional engineer. No evaluation is offered for the host supporting structure by use of this document; Adjustment factors noted herein and the applicable codes must be considered, where applicable. All supporting components which are permanently installed shall be protected against corrosion, contamination, and other such damage at all times. Fasteners must penetrate the supporting members such that the full length of the threaded portion is embedded within the main member. This evaluation does not offer any evaluation to meet large missile impact debris requirements which typically are not required for this type of product. All of the wind resisting exterior panels, individually meet or exceed their capacity to resist the design wind loads as stated in the calculations as required by the FBC. Due to the indeterminate nature of these units, distortion and deflection cannot be accurately evaluated, but with diaphragm action of external components and internal stiffeners, the base unit has the capacity to withstand these forces with individual external parts being contained. Yearly inspections, during equipment maintenance or after named storm, all screws, cabinet components, clips and anchor bolts are to be verified by the AVC contractor. All damaged cabinet components, loose, corroded, broken tech screws or anchor bolts shall be replaced to ensure structural integrity for hurricane wind forces.

Revision #	Description	Initials	Date
0	Initial Submittal	LAO	11/19/19